

PENNICHUCK WATER WORKS

Nashua, New Hampshire

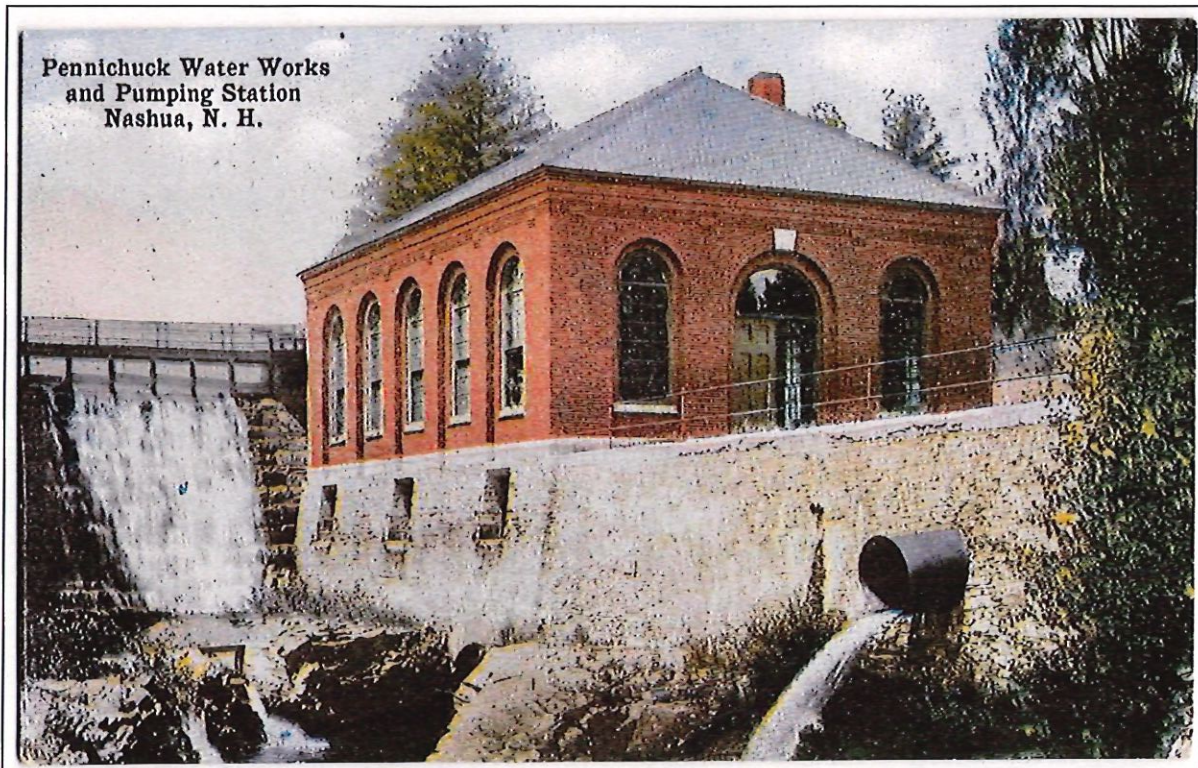

Technical Specifications for Water Main, Hydrant, and Service Installations

Revision – April 2026

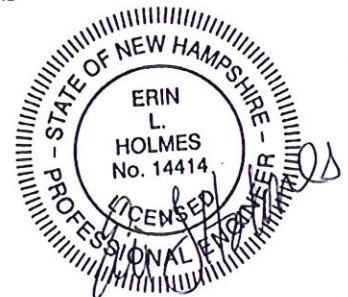

Foreword

These *Technical Specifications for Water Main, Hydrant, and Service Installations* are the standards for construction for Pennichuck Water Works Contract Administrators in the administration of Pennichuck construction projects. The Pennichuck companies are: Pennichuck Water Works (PWW) and Pennichuck Water Service Company (PWSC).

These are techniques and methods that will assist Pennichuck personnel in accomplishing the satisfactory completion of water works projects in accordance with the controlling Drawings, Specifications, and other Contract documents, and in ensuring proper quality and quantity control.

These *Technical Specifications for Water Main, Hydrant, and Service Installations* are a compilation of the best water line construction practices based on the experience of Pennichuck Water Works Engineers. Only after the Drawings and Specifications have been read and understood will the Specifications serve their purpose. Each water works employee and Contractor will be expected to become thoroughly familiar with the contents of these Specifications and to study them carefully to achieve a well-rounded knowledge of the operations employed by the industry and good judgment in applying these Specifications in the administration of Pennichuck Water Works Contracts.

General Note: These *Technical Specifications for Water Main, Hydrant, and Service Installations* reference the latest version of the State of New Hampshire, Department of Transportation, NHDOT Standard Specifications for Road and Bridge Construction. Wherever the NHDOT Specifications are referenced by section or subsection, that section or subsection of the NHDOT Specifications shall be considered part of these Pennichuck Water Works *Technical Specifications for Water Main, Hydrant, and Service Installations*.

Technical Specifications for Water Main, Hydrant, and Service Installations

Master Table of Contents

Section 01000 Special Conditions

Section 01100 General Specifications

Section 01200 Temporary Facilities

Section 01300 Clearing and Grubbing

Section 01400 Earth Excavation, Backfill, Fill, and Grading

Section 01500 Rock Excavation and Disposal

Section 01525 Blasting

Section 01550 Vibration, Seismic, and Acoustic Monitoring

Section 01600 Water Main Pipe and Fittings

Section 01625 Polyethylene Encasement

Section 01650 Water Service and Air Release Materials

Section 01660 Clean and Lining – Cast Iron Water Mains

Section 01670 Asbestos Cement Pipe

Section 01680 Temporary Water Mains and Services

Section 01800 Crushed Gravel

Section 01900 Gravel Aggregate for Road Base and Water Main Backfill

Section 02000 Common Borrow

Section 02100 Sand

Section 02200 Loam & Seed

Section 02250 Chain Link Fencing

Section 02300 Paving

Section 02400 Concrete Thrust Blocks

Section 02450 Styrofoam Insulation

Section 02500 Managing Water Flow during Construction

PENNICHUCK WATER WORKS

Section 02550 Dust Control
Section 02600 Clean Up
Section 02700 Measurement and Payment
Appendix A..... Hydrant and Valve Opening Direction
Appendix B..... Standard Details List
Appendix C..... Standard Details

SECTION 01000
Special Conditions

Table of Contents

A..... GENERAL
B..... RESOLVING CONFLICTS OR INCONSISTENCIES
C..... TRAFFIC CONTROL
D..... PAVING OPERATIONS
E..... INSURANCE COVERAGE
F..... CURRENT RECORD DRAWINGS
G..... PRE-CONSTRUCTION VIDEO
H..... SPECIAL INSTALLATION OF WATER MAIN

A

GENERAL

1. Water Main and Water Service Shutdowns

The Contractor must notify the Engineer a minimum of 72 hours before shutting down any water main and 24 hours before shutting down any water service.

Pennichuck will provide the necessary crews at no cost to the Contractor to operate the water valves required for each water main shutdown and for the reactivation of the water main. In no case shall a water main be shut down for more than 12 hours. If an emergency or anticipated shut down requires that a water main be shut down for more than 12 hours, the Contractor shall provide 2 gallons of bottled water to each affected resident.

2. Permits

Permits and licenses of a temporary nature necessary for the prosecution of the work shall be obtained and paid for by the Contractor. Permit types may include the following:

- Construction Dewatering Permit
- EPA Dewatering Permit
- Municipal Street Opening Permit
- Municipal Emergency Permit
- Notice of Intent (NOI) to discharge wastewater from construction sites
- Stormwater Pollution Prevention Plan (SWPPP)
- Asbestos Cement Pipe

3. Conforming to Plans and Specifications

All work shall conform to these Specifications and/or the accompanying Project Drawings.

4. Site Visits

Before submitting a bid, the Contractor shall visit the work site or sites. These work sites shall be available for viewing at the Contractor's convenience. During such visits, the Contractor shall examine the existing conditions and thoroughly acquaint themselves with the obstacles and advantages of performing the work.

The Contractor shall also study the construction documents and compare them with the information gathered during the site examination. No extra compensation will be authorized for extra work caused by the Contractor's unfamiliarity with the site, the construction documents, or conditions that may be unusual to the project.

5. Submittals

The Contractor shall submit digital copies of complete and acceptable shop Drawings to the Owner for approval a minimum of two weeks before the intended use for the following Items:

- All pipe, fittings, and valves
- Construction schedule (If required)

The schedule shall present a critical path with dates for critical phases of the work.

If required, the Contractor shall submit compliance certification for the American Iron and Steel (AIS) provision that State and Federal Funding Programs require.

AIS compliance certifications must include the following information:

- Project name
- Specific product description
- Nation of origin
- Reference to AIS requirements
- Manufacturer or vendor representative's signature

B

RESOLVING CONFLICTS OR INCONSISTENCIES

If there are any conflicts or inconsistencies between the provisions of the Special Conditions and the provisions of the other Contract Documents, the provisions of the Special Conditions shall prevail. If there is any conflict or inconsistency between the provisions of the Agreement and the provisions of any of the Contract Documents other than the Special Conditions, the conditions of the Agreement shall prevail. In all cases, the judgement of the Pennichuck representative shall supersede all other conditions.

C

TRAFFIC CONTROL

- All traffic control will be provided by municipal Police Departments or by others approved by the municipal Police Department.
- Flaggers shall to be certified by the ATSSA (American Traffic Safety Services Association) or a comparable organization. Flaggers must provide proof of certification upon request. Flagging organizations should provide copies, up front, of their employee certifications with other submittals.
- Flaggers must be equipped with PPE, traffic control signage, flags, barriers, barricades and any other required MUTCD devices for traffic control purposes. Flaggers must be provided with appropriate breaks for lunch, relief from weather conditions, and other necessities.
- The work hour schedule shall be in accordance with municipal requirements.
- Signage shall be in accordance with the Drawings or as approved by the municipal Police Department, the municipal Public Works Department, and the Manual of Uniform Traffic Control Devices (MUTCD).

D

PAVING OPERATIONS

1. Paving Restoration

All paving restoration shall be carried out in accordance with the Drawings and Specifications.

2. Dust Control

The Contractor shall always provide dust control for each street during construction and shall be responsible for maintaining the road in a level, passable condition. Upon completion of the base asphalt pavement, the Contractor will only be responsible for dust control and sweeping due to their construction-related activities.

3. Asphalt Cement Price Adjustments

Adjustments for increases or decreases in Asphalt Cement prices for Pennichuck Water Works capital projects only will be carried out in accordance with the latest NH DOT *Special Attention with regards to Asphalt Cement Adjustment* as posted on the NH DOT web site on the day of the bid opening.

E

INSURANCE COVERAGE

The local municipality and Pennichuck shall be provided with insurance certificates, naming both parties as additional named insured in accordance with general conditions. For Developer projects, insurance coverage requirements are specified in the main Extension Agreement.

F

CURRENT RECORD DRAWINGS

During the Work, the Contractor and applicable Subcontractors shall continually maintain a set of legibly-marked prints, Drawings, and sketches showing any changes made during the construction process. This set of prints shall be incorporated into one complete set of full D-size paper Drawings by the Contractor following completion of work. The Contractor shall make any revisions required by the Engineer to make the Record Drawings complete and up-to-date.

After acceptance by the Engineer, the full-size paper Drawings shall be given to the Engineer. These record Drawings shall be completed in every way with attention given to properly delineating concealed work which would be difficult to measure later. Change orders, addenda Items, and field changes should be noted where applicable. Additional specific requirements relative to Record Drawings may be called for in the individual sections of these Specifications.

G

PRE-CONSTRUCTION VIDEO

Prior to any excavation or disturbance, the Contractor shall video all potential areas to be disturbed by the proposed project. It is encouraged, if possible, to perform the video after a significant rain event. The Contractor shall provide three copies of this video on USB flashdrives or upload to the Pennichuck Sharefile site. Pre-construction video will be approved after review by Pennichuck that the video clearly depicts the entire proposed work area and any potential areas that could be disturbed due to Contractor activities related to the project.

H

SPECIAL INSTALLATION OF WATER MAIN

Water main shall be installed in accordance to the Specifications and Drawings.

1. Suspended to a Bridge

Suspension of a water main to a bridge is not a preferred method and will only be accepted by Pennichuck Water when there are no other practical methods or options available. Cost is not the primary consideration in determining a practical method or option.

SECTION 01100
General Specifications

Table of Contents

A..... DEFINITIONS

B..... ABBREVIATIONS

C..... HANDLING AND DISTRIBUTING MATERIALS

D..... SAMPLING AND INSPECTING MATERIALS

E..... CONTRACTOR’S SHOP AND WORKING DRAWINGS

F..... OCCUPYING PRIVATE LAND

G..... INTERFERENCE WITH AND PROTECTION OF STREETS

H..... STORING MATERIALS AND EQUIPMENT

I..... SAFETY MEASURES

J..... SANITARY REGULATIONS

K..... ESTABLISHING LINES, GRADES, AND MEASUREMENTS

L..... DIMENSIONS OF EXISTING STRUCTURES

M..... CONFORMING TO LINES, LEVELS, AND GRADES

N..... PIPE AND FITTING LOCATIONS

O..... LIMITS OF NORMAL EXCAVATION

P..... COMPUTING QUANTITIES

Q..... PLANNING AND PROGRESS SCHEDULES

R..... PRECAUTIONS DURING ADVERSE WEATHER

S..... ELECTRIC POWER

T..... PRE-CONSTRUCTION ASSESSMENT

U..... NHDOT SPECIFICATION REFERENCES

A

DEFINITIONS

Wherever the words defined in this section or pronouns used in their stead occur in the Contract Documents, they shall have the meanings herein given.

Wherever in the Contract Documents, or on the Drawings, the words “As directed,” “As ordered,” “As requested,” “As required,” “As permitted,” or words of like import are used, it shall be understood that the direction, order, request, requirement, or permission of the Owner’s Representative is intended. Similarly, the words “approved,” “acceptable,” “suitable,” “satisfactory,” and words of like import shall mean approved by, acceptable to, suitable to, or satisfactory to the Owner’s Representative.

1. Elevation

The figures given on the Drawings or in the other Contract Documents after the word “elevation” or abbreviation of it shall mean the distance in feet above the datum specified by the Owner’s Representative.

2. Rock

The word “rock,” wherever used as the name of an excavated material or material to be excavated, shall mean only boulders and pieces of concrete or masonry exceeding one cubic yard in volume, or solid ledge rock which, in the opinion of the Owner’s Representative, requires for its removal, drilling and blasting, wedging, sledging, barring, or breaking up with a power-operated tool. No soft or disintegrated rock which may be removed with a hand pick or power-operated excavator or shovel, no loose, shaken, or previously blasted rock or broken stone in rock fillings or elsewhere, and no rock exterior to the maximum limits of measurement allowed, which may fall into the excavation, will be measured or allowed as “rock.”

3. Earth

The word “earth”, wherever used as the name of an excavated material or material to be excavated, shall mean all kinds of material other than rock as previously defined.

4. Owners

Pennichuck Water Works (Pennichuck Water Works) or Pennichuck Water Service Company (PWSC).

5. Owner’s Representative

A Manager, Engineer, or Field Inspector employed by Pennichuck Water Works with delegated responsibility for the project.

6. Contractor

The company responsible for the installation of the water main, services, and appurtenances.

7. Engineer

The Engineer of Record for the project.

8. Developer

A transitional owner of a project requiring the installation of a water main or water services.

B

ABBREVIATIONS

Where any of the following abbreviations are used in the Contract Documents, they shall have the meaning set forth as follows:

- 125-lb. ANS..... American National Standard for Cast-iron
- 250-lb. ANS..... American National Standard for Pipe Flanges and Flanged Fittings
(*Designation B16.1-1975*, for the appropriate class)
- AASHTO..... American Association of State Highway and Transportation Officials
- ACI..... American Concrete Institute
- ACM Asbestos-Containing Material
- ACP..... Asbestos Cement Pipe
- ACWM Asbestos-Containing Waste Material
- AI Asbestos Inspector
- AISC American Institute of Steel Construction
- AIS American Iron and Steel – Provisions
- ANS American National Standard

PENNICHUCK WATER WORKS

ANSI.....	American National Standards Institute
ARD.....	NHDES Air Resources Division
ASCE.....	American Society of Civil Engineers
ASTM.....	American Society for Testing and Materials
AWG.....	American or Brown and Sharpe Wire Gauge
AWWA.....	American Water Works Association
BMP.....	Best Management Practices
BV.....	Butterfly Valve
CC.....	Copper Connection
CFR.....	Code of Federal Regulations
CL.....	ANSI Pipe Thickness Class
CMP.....	Corrugated Metal Pipe
CT.....	Copper Tubing
CTS.....	Copper Tubing Sized
DI.....	Ductile Iron
DIPCL.....	Ductile Iron Pipe Cement-Lined
DIPS.....	Ductile Iron Pipe Sized
FBE.....	Fusion-Bounded Epoxy
FIP.....	Female Iron Pipe
GV.....	Gate Valve
HDPE.....	High-Density Polyethylene Pipe
HEPA.....	High-Efficiency Particulate Air
IP.....	Iron Pipe
IPS.....	Iron Pipe Sized
ISO.....	International Organization for Standardization
L.A.R.O.W.....	Limited Access Right-of-Way
MJ.....	Mechanical Joint
MUTCD.....	Manual on Uniform Traffic Control Devices
NESHAP.....	National Emissions Standards for Hazardous Air Pollutants

PENNICHUCK WATER WORKS

NHDES New Hampshire Department of Environmental Services
NHDOT New Hampshire Department of Transportation
NOI Notice of Intent
NPT National Pipe Thread
NSF National Science Foundation
OL Open Left
OR Open Right
OS & Y Outside Screw and Yoke
OSHA Occupational Safety and Health Administration
PE Polyethylene Pipe
PJ Pack Joint
PRV Pressure Reducing Valve
PVC Polyvinyl Chloride
PWSC Pennichuck Water Service Company
PWW Pennichuck Water Works
RACM Regulated Asbestos-Containing Material
ROW Right-of-Way
RS Resilient Seat
SBR Styrene Butadiene Rubber
SS Stainless Steel
SWPPP Stormwater Pollution Prevention Plan
TOP Top of Pipe

C

HANDLING AND DISTRIBUTING MATERIALS

The Contractor shall handle, haul, and distribute all materials and all surplus materials on the different portions of the Work, as necessary or required. They shall provide suitable and adequate storage room for materials and equipment during the progress of the Work, and be responsible for the

protection, loss of, or damage to materials and equipment furnished by them, and those provided by the Owner for use by the Contractor, until the Final Completion date and acceptance of the Work.

Facilities and labor for the storage, handling, and inspection of all materials and equipment shall be furnished by the Contractor. Defective materials and equipment shall be removed immediately from the site of the Work.

Storage and demurrage charges by transportation companies and vendors shall be borne by the Contractor.

D

SAMPLING AND INSPECTING MATERIALS

Unless otherwise expressly provided on the Drawings or in any of the other Contract Documents, only new materials and equipment shall be incorporated in the Work. All materials and equipment furnished by the Contractor to be incorporated in the Work shall be subject to the inspection of the Owner's Representative. No material shall be processed or fabricated for the Work or delivered to the Work site without prior concurrence of the Owner's Representative.

As soon as possible after execution of the Agreement, the Contractor shall submit to the Owner's Representative the names and addresses of the manufacturers and suppliers of all materials and equipment that they propose to incorporate into the Work. When Shop and Working Drawings are required as specified below, the Contractor shall submit data in sufficient detail to enable the Owner's Representative to determine whether the manufacturer and/or the supplier have the ability to furnish a product meeting the Specifications. Once the manufacturer and/or supplier have been approved, the Contractor shall then submit their Shop and Working Drawings.

As requested, the Contractor shall also submit data relating to the materials and equipment that they propose to incorporate into the Work in sufficient detail to enable the Owner's Representative to identify and evaluate the particular product and to determine whether it conforms to the Contract requirements. Such data shall be submitted in a manner similar to that specified for submission of Shop and Working Drawings.

If the Owner's Representative so requires, either prior to or after commencement of the Work, the Contractor shall submit samples of materials for such special tests as the Owner's Representative deems necessary to demonstrate that they conform to the Specifications. Except as otherwise expressly specified, the Owner shall plan for, and pay for, these tests.

All samples shall be properly packed so that they reach their destination in good condition, and shall be labeled to indicate the material represented, the name of the work and location for which the material is intended, and the name of the Contractor submitting the sample. To ensure consideration of samples, the Contractor shall notify the Owner's Representative that the samples have been shipped and shall properly describe the samples.

The Contractor shall submit data and samples, or place their orders, sufficiently early to permit consideration, inspection, and testing before the materials and equipment are needed for incorporation in the Work. The consequences of their failure to do so shall be the Contractor's sole responsibility.

When required, the Contractor shall furnish to the Owner's Representative duplicate sworn copies of manufacturer's shop or mill tests (or reports from independent testing laboratories) relative to materials, equipment performance ratings, and concrete data.

After review of the samples, data, etc., the materials and equipment used on the Work shall in all respects conform to these Specifications.

E

CONTRACTOR'S SHOP AND WORKING DRAWINGS

The Contractor's Shop and Working Drawings shall be submitted as designated in each Specification section.

F

OCCUPYING PRIVATE LAND

In the absence of written consent from the proper parties, the Contractor shall not enter or occupy with personnel, tools, materials, or equipment, any land outside the rights-of-way, or property of the Owner. A copy of the written consent shall be submitted to Pennichuck Water Works.

Pennichuck Water Works will not be responsible for any restoration costs or fees associated with land subject to the written consent agreement.

G

MAINTAINING ACCESS TO THE TRAVELLED RIGHT-OF-WAY

The Contractor shall not close or obstruct any portion of a street, road, or private way without obtaining permits therefore from the proper authorities. If any street, road or private way shall be rendered unsafe by the Contractor's operations, they shall make such repairs or provide such temporary ways or guards as shall be acceptable to the proper authorities.

Streets, roads, private ways, and walks not closed shall be maintained passable and safe by the Contractor, who shall assume and have full responsibility for the adequacy and safety of provisions made therefore.

The Contractor shall comply fully with all NHDOT and/or local municipality standards and Specifications for posting of roadways as related to the type of work. Areas requiring stripping of pavement shall also be posted and reconstructed in accordance with NHDOT and/or local municipality standards and Specifications.

H

STORING MATERIALS AND EQUIPMENT

All excavated materials and equipment to be incorporated in the Work shall be placed so as not to injure any part of the Work or existing facilities and so that free access can be had at all times to all parts of the Work and to all public utility installations in the vicinity of the Work. Materials and equipment shall be kept neatly piled and compactly stored in such locations as will cause a minimum of inconvenience to public travel and adjoining owners, tenants and occupants.

Confinements such as erosion control measures shall also be employed where required by the Owner's Representative at no extra cost to the Owner.

I

SAFETY MEASURES

The Contractor shall take all necessary precautions and provide all necessary safeguards to prevent personal injury and property damage. The Contractor shall provide protection for all persons

including but not limited to their employees and employees of other Contractors or subcontractors; members of the public; and employees, agents, and representatives of the Owner, the Owner's Representative, and regulatory agencies that may be on or about the Work. The Contractor shall provide protection for all public and private property including but not limited to structures, pipes, and utilities, above and below ground.

The Contractor shall provide and maintain all necessary safety equipment such as fences, barriers, signs, lights, walkways, guards, and fire prevention and fire-fighting equipment, and shall take such other action as is required to fulfill their obligations under this subsection.

The Contractor shall comply with all applicable Federal, State and local laws, ordinances, rules and regulations and lawful orders of all authorities having jurisdiction for the safety of persons and protection of property. This includes, but is not limited to, current excavation shoring standards as outlined by OSHA, the use of hard hats, safety vests, etc.

All such safety equipment will be provided and maintained in "good" condition by the Contractor at no expense to the Owner. Failure to comply with current safety standards and requirements subjects the Contractor to immediate suspension of Work and requires them to pay off any and all fines, penalties, and assessments levied against them by the party having jurisdiction.

Contractors employed by the owner will be subject to immediate suspension of work when unsafe working conditions on the work site are present or indicated. Safety violations shall be documented for contractors not employed by the owner who are involved with unsafe working conditions on the work site.

The Contractor shall designate a responsible member of their organization at the site whose duty shall be the implementation of safety measures and prevention of accidents. This responsible person shall have the authority to take immediate action to correct any unsafe or hazardous conditions and to enforce all safety precautions and programs.

J

SANITARY REGULATIONS

The Contractor shall provide adequate sanitary facilities for the use of those employed on the project. Such facilities shall be made available when the first employees arrive on the site of the Work, shall be properly secluded from public observation, and shall be constructed and maintained during the progress of the Work in suitable numbers at such points and in such manner as may be required by the Owner's Representative.

The Contractor shall always maintain the sanitary facilities in a satisfactory and sanitary condition and shall enforce their use. They shall rigorously prohibit the committing of nuisances on the site of the Work, on the lands of the Owner, or any adjacent property.

K

ESTABLISHING LINES, GRADES, AND MEASUREMENTS

The Contractor shall employ a competent person to establish all lines, elevations, reference marks, batter boards, etc., needed by the Contractor during the progress of the Work, and from time-to-time, to verify such marks by instrument or other appropriate means.

The Contractor is responsible for all layout including, but not limited to, clearing limits and re-staking the centerline. The Owner's Representative shall always be permitted to check the lines, elevations, reference marks, batter boards, etc., set by the Contractor, who shall correct any errors in lines, elevations, reference marks, batter boards, etc., disclosed by such a check.

However, this evaluation shall not be construed to be an approval of the Contractor's work and shall not relieve or diminish in any way the responsibility of the Contractor for the accurate and satisfactory construction and completion of the entire Work.

The Contractor shall produce, verify, and be responsible for all measurements and dimensions necessary for the proper construction of the Work and the prevention of any misalignments in the pipe run.

L

DIMENSIONS OF EXISTING STRUCTURES

Where the dimensions and locations of existing structures are of importance in the installation or connection of any part of the Work, the Contractor shall verify such dimensions and locations in the field before the fabrication of any material or equipment which is dependent on the correctness of such information.

M

CONFORMING TO LINES, LEVELS, AND GRADES

During its progress and on its completion, the Work shall conform truly to the lines, levels, and grades indicated on the Drawings or given by the Owner's Representative. The Work shall be built in a thoroughly substantial and workmanlike manner, in strict accordance with the Drawings, Specifications, other Contract Documents, and the directions given from time-to-time by the Owner's Representative.

All work done without instructions having been given by the Owner's Representative, without proper lines or levels, or performed during the absence of the Owner's Representative, will not be estimated or paid for except when such work is authorized by the Owner's Representative in writing. Work so done may be ordered uncovered or taken down, removed, and replaced at the Contractor's expense.

N

PIPE AND FITTING LOCATIONS

Exterior pipelines will be located as indicated on the Drawings, but the right is reserved to the Owner's Representative to make such modifications in location as may be found desirable to avoid interference with existing structures or for other appropriate reasons.

Where fittings, etc., are noted on the Drawings, such notation is for the Contractor's convenience and does not relieve them from laying and jointing different or additional Items where required. Grades shown are for control purposes. Deflections shown on the Drawings are approximate and may vary in the field. The Contractor shall always maintain the cover specified over the top of pipe.

O

LIMITS OF NORMAL EXCAVATION

The normal excavation limits are subject to the discretion of the Contractor, based on their safety, environmental, and Contract obligations. The normal excavation width for the water main shall be a maximum of 6 feet, as measured from the vertical planes which constitute the trench sidewalls unless otherwise designated on the Plans. The normal trench depth shall be as detailed on the Plans and as measured from the existing pavement at the roadway shoulder.

Pipes shall be installed within the confines of this trench as detailed on the Plans.

For concrete placed directly against undisturbed earth, the normal width and depth of the excavation for such concrete shall be measured to the neat lines of the concrete as indicated on the Drawings or as ordered. No excavation outside of the limits of normal excavation for concrete shall be made without permission of the Owner's Representative.

For concrete placed against rock surfaces resulting from rock excavation, the normal width and depth of the excavation shall be measured to 4 inches outside the neat lines of the concrete as indicated on the Drawings or as ordered. No excavation outside of the limits of normal excavation for concrete shall be made without permission of the Owner's Representative.

Ledge excavation may be authorized beyond the limits of the normal trench width as requested by the Owner's Representative to remove broken or loose rock.

For other appurtenances, such as branch lines, hydrants, and additional services, the normal width shall be measured between vertical planes 1 foot outside the neat lines of the appurtenances, except that the width shall not be less than 4 feet. The normal depth shall be determined in the same manner as that specified above. No extra payment shall be made for these appurtenances even where excavation occurs outside the normal trench limits.

P

COMPUTING QUANTITIES

The computation of the volume of prisms shall be by the method of average end-areas.

Q

PLANNING AND PROGRESS SCHEDULES

Before starting the Work and from time-to-time during its progress, as the Owner's Representative may request, the Contractor shall submit to the Owner's Representative a written description of the methods they plan to use in doing the Work and the various steps they intend to take.

Within five days after the date of formal execution of the Agreement, the Contractor shall prepare and submit to the Owner's Representative a written schedule fixing the dates on which additional Drawings, if any, will be needed by the Contractor and a written schedule fixing the respective dates

for the start and completion of various parts of the Work. Each such schedule shall be subject to review from time-to-time during the progress of the Work.

R

TAKING PRECAUTIONS DURING ADVERSE WEATHER

During adverse weather and against the possibility thereof, the Contractor shall take all necessary precautions so that the Work may be properly done and satisfactory in all respects. When required, protection shall be provided by use of tarpaulins, wood and building paper shelters, or other suitable means.

S

ELECTRIC POWER

The Contractor shall make all necessary applications and arrangements and pay all fees and charges for electric power and lighting necessary for the proper completion of the Work and during its entire progress. The Contractor shall provide and pay for all temporary wiring, switches, connections, and meters.

T

PRE-CONSTRUCTION ASSESSMENT

Prior to the deployment of any equipment or materials to the project site, the Contractor shall conduct a project-wide assessment of conditions, noting any existing damage and deficiencies within the right-of-way and on private property immediately adjacent to the right-of-way.

The Contractor shall compile a detailed digital video recording of each street, made at a walking pace to ensure that all conditions are comprehensively documented. The Contractor shall also endeavor to make a digital video recording immediately following a significant rain event to document any existing drainage issues in the area that may occur. The digital video recording shall be date and time stamped. The Contractor shall provide the owner with a copy of the digital video recording and a copy of the Contractor's assessment of pre-construction conditions.

U

NHDOT SPECIFICATION REFERENCES

These Specifications reference the latest version of the State of New Hampshire, Department of Transportation, Standard Specifications for Road and Bridge Construction. Wherever the State of New Hampshire Specifications are referenced by Section, that Section of the Specification shall be considered part of these Specifications.

SECTION 01200
Temporary Facilities

Table of Contents

A..... GENERAL
B..... TEMPORARY FACILITY WATER SUPPLY
C..... TEMPORARY FACILITY ELECTRICITY
D..... TEMPORARY FACILITY SANITARY ACCOMMODATIONS
E..... SIGNAGE
F..... BARRICADES AND GUARD LIGHTS
G..... CONTRACTOR'S BUILDING

A

GENERAL

The Contractor shall provide all temporary facilities necessary for the proper completion of the Work, as necessary and as specified. The Contractor shall adhere to the requirements of the General Specifications specified under “Sanitary Regulations”, “Precautions During Adverse Weather”, and “Electrical Energy.”

B

TEMPORARY FACILITY WATER SUPPLY

The Contractor, with the approval of the Owner, may make connection to a fire hydrant within the project area and use this supply for construction purposes. The Contractor shall bear the cost of water used for construction purposes. The Owner shall install a water meter on the fire hydrant that the Contractor intends to use. Meter size options are either 3” or 1”. The Contractor shall furnish and install a backflow preventer on this connection.

The Contractor must first obtain approval for making the hydrant connection from Pennichuck by contacting Meter Department Supervisor at (603) 913-2388 and requesting the “Construction Hydrant Water Meter” form. The Contractor shall return this completed form to Pennichuck with a deposit in the amount of \$1000.00 for a 3” meter, \$850.00 of which is refundable when the meter is returned in acceptable condition when operations have concluded. A deposit of \$330.00 is required for a 1” meter with a refund amount of \$200.00 when the meter is returned in acceptable condition. Pennichuck reserves the right to charge the Contractor for additional costs if a meter is damaged and requires repair or replacement costs greater than the initial deposit. Invoices for water usage shall be submitted to the Contractor each month. Contractor is responsible for the monthly meter fee. Monthly meter rates and water usage rates can be found at www.pennichuck.com; follow the General Information & Rate Information links. The Contractor will also be required to provide a 2.5” NST/fire hose swivel adaptor as well as a Reduce Pressure Zone (RPZ) backflow device. Pennichuck reserves the right to remove a construction meter if the Contractor fails to use the required backflow device and the Contractor will be prohibited from using water for construction purposes until the proper backflow device has been installed.

The time limit for the use a of construction meter is 90 days. If the Contractor requires use of the hydrant connection past 90 days, they shall contact Customer Service again to request additional time.

All connections required for temporary water shall be furnished by the Contractor at their expense. Refer to *Standard Detail T01* for more information.

C

TEMPORARY FACILITY ELECTRIC POWER

The Contractor shall arrange for, furnish, maintain, and pay for the electricity used for pumping, lighting, powering tools, and the electrification of the field offices, up to the time of final acceptance.

D

TEMPORARY FACILITY SANITARY ACCOMMODATIONS

Sanitary accommodations for the use of all persons employed on the work, properly screened from public observation, shall be provided in sufficient numbers, in such a manner, and at such locations deemed acceptable to the Owner's Representative. The contents shall be removed and disposed of in a manner and at a frequency acceptable to the public health agency having jurisdiction. The proper maintenance of sanitary conveniences shall be the obligation and responsibility of the Contractor until the completion of the Work.

E

SIGNAGE

All signs required by regulatory agencies shall be furnished, installed, and maintained by the Contractor. Any permits required to erect signs shall be obtained by the Contractor. The Contractor shall submit copies of signage plans as required in the Special Conditions section of these Specifications.

F

INSTALLING BARRICADES AND GUARD LIGHTS

Barricades, signs, fences, and similar safety and warning devices shall be provided as required to ensure the protection of the public, as well as employees of the Contractor, the Owner, and the Owner's Representative. Guard lights shall be furnished and installed at all barricades, obstructions in streets and sidewalks, and at all trenches and pits adjacent to public roads. All directional and warning devices furnished shall conform with the MUTCD.

G

PROVIDING TEMPORARY CONTRACTOR FACILITIES

The Contractor shall provide temporary office, storage, and fabrication facilities for their use as required and obtain all necessary applicable permits and/or approvals required for their use. The location or locations of such buildings shall be the responsibility of the Contractor and shall be completely removed at the completion of work.

Any costs due to relocation shall be the responsibility of the Contractor.

Drinking water, satisfactorily cooled, shall also be provided by the Contractor at the temporary facility.

SECTION 01300
Clearing and Grubbing

Table of Contents

A..... GENERAL
B..... RELATED WORK
C..... EXECUTION

A

GENERAL

This work by the Contractor shall consist of clearing, grubbing, removing, and disposing of all vegetation and debris within the limits shown on the Plans or as specified below, except such objects as are designated to remain or are to be removed in accordance with the other sections of these Specifications. This work shall also include the preservation from injury or defacement of all vegetation and objects designated to remain.

B

RELATED WORK

Section 01400 Earth Excavation, Backfill, Fill, and Grading

Section 01900 Gravel Aggregate for Road Base and Water Main Backfill

Section 02200 Loam & Seed

C

EXECUTION

1. Removing Trees and Shrubs

All trees, shrubs, and stumps shall be removed from within the grubbing areas as designated on the Plans. No trees or shrubs shall be removed from outside the designate clearing area without the written consent of the Owner's Representative. Any trees or shrubs located outside of the clearing limits which are cut or scarred during the construction process shall be painted with an approved wound dressing or treated per other accepted arboricultural practices.

2. Removing Stumps and Large Roots

All stumps and large roots within the clearing area shall be removed to a depth of 6 inches below the invert of the water main. All stumps and large roots must be removed completely under areas to be backfilled with structural fill.

3. Properly Disposing of Solid Waste

All stumps, roots, branches, brush, weeds, and other grubblings shall be removed from the site and disposed of by an approved method. The Contractor's attention is directed to New Hampshire *Revised Statute § 149-M:4** regarding the fact that stumps and roots from grubbing operations have been classified as solid waste. As such, these stumps shall be disposed of in permitted sites through firms having facilities and the ability to process the stumps and roots in accordance with NHDES regulations. It is the responsibility of the Contractor to obtain all permits required to comply with the New Hampshire Solid Waste Rules and Design standards in effect at the time of the disposal.

4. Filling Excavated Areas

All excavated areas outside the limits of the structural fill placement resulting from grubbing operations shall be filled with common borrow. Borrow shall be placed and compacted to conform to the surrounding ground.

5. Wood Harvesting Rights

The property owner shall have the first right of refusal for any useful wood harvested during any wood-clearing operations.

* *2015 New Hampshire Revised Statutes, Title X - PUBLIC HEALTH, Chapter 149-M - SOLID WASTE MANAGEMENT, Section 149-M:4 – Definitions.*

PENNICHUCK WATER WORKS

[This page has been left intentionally blank]

SECTION 01400

Earth Excavation, Backfill, Fill, and Grading

Table of Contents

A..... GENERAL
B..... RELATED PRODUCTS
C..... QUALITY ASSURANCE
D..... SAFETY
E..... PRODUCTS
F EXECUTION

A

GENERAL

Pipe trench excavations shall be made to the depth and width specified in the Drawings and Details. Excavation work shall also include backfilling such excavations, making miscellaneous earth excavations, and performing miscellaneous grading.

B

RELATED WORK

- Section 01000 Special Conditions
- Section 01300 Clearing and Grubbing
- Section 01500 Rock Excavation and Disposal
- Section 01525 Blasting
- Section 01600 Ductile Iron Pipe Installation
- Section 01800 Crushed Gravel
- Section 01900 Gravel Aggregate for Road Base and Water Main Backfill
- Section 02000 Common Borrow
- Section 02200 Loam and Seed
- Section 02400 Concrete Thrust Blocks

C

QUALITY ASSURANCE

1. Determining Soil Compaction

Wherever a percentage of compaction is indicated or specified, use percent of maximum density at optimum moisture as determined by the requirements of *ASTM D 1557, Standard Test Methods for Laboratory Compaction Characteristics of Soil Using Modified Effort (56,000 ft-lbf/ft³ (2,700 kN-m/m³))*.

2. Open Trench Length

The length of trench open at any one time will be controlled by conditions and subject to any limits that may be prescribed by the Owner's Representative. In general, open lengths of trench will be kept to a minimum.

3. Underground Utilities

There may be pipes, drains, and other utilities in certain locations not indicated on Drawings. The completeness or accuracy of information given is not guaranteed.

Important: Final confirmation of all underground utilities and their location on public property is the responsibility of the Contractor and shall be confirmed through the Dig Safe System, Inc. notification process. If a utility is not a member of "Dig Safe," then the Contractor shall confirm utility locations through the municipality, or the third party that either owns or maintains the utility. The Contractor is also responsible for locating utilities on private property.

4. Preventing Damage to Existing Items

All existing pipes, poles, wires, fences, curbing, property line markers, and other structures which the Owner's Representative decides must be preserved in place without being temporarily or permanently relocated, shall be carefully supported and protected from damage by the Contractor. Should such items be damaged, they shall be restored by the Contractor, without compensation therefore, to at least as good condition as that in which they were found immediately before the work was begun.

5. Previously Unknown Structures

Whenever the Contractor encounters certain existing structures within the normal scope of work not previously identified (as described below and is so ordered in writing), they shall do the whole or such portions of the work as he may be directed to change the location of, remove and later restore, or replace such structures, or to assist the Owner thereof in so doing. For all such work the Contractor shall be paid under such Items of work as may be applicable, otherwise it shall be reimbursed as Extra Work.

These previously unknown structures may include pipes, wires, and other structures which meet all of the following criteria:

- The structures are not indicated on the Drawings or otherwise provided for.
- The structures encroach upon or are encountered near and substantially parallel to the edge of the excavation.

- The structures, in the opinion of the Owner's Representative, will impede progress to such an extent that satisfactory construction cannot proceed until they have been changed in location, removed (to be later restored), or replaced.

6. New Materials

In removing existing pipes or other structures, the Owner's Representative shall include for payment only those new materials which, in his judgment, are necessary to replace those unavoidably damaged.

7. Restoring Existing Property

Restoration of existing property or structures shall be done as promptly as practicable. All disturbed drives, walkways and roadways shall be returned to service at the end of each workday unless otherwise approved by the Owner's Representative.

8. Disposing Surplus Materials

Surplus excavated materials not needed as specified above shall be hauled away and dumped by the Contractor, at their expense, to locations approved by authorities having jurisdiction and in accordance with arrangements made by the Contractor.

9. Minimizing the Generation and Dispersion of Dust

During progress of work, Contractor shall conduct their operations and maintain their area of activities, including sweeping and sprinkling of streets as necessary, to minimize the generation and dispersion of dust.

10. Temporary Roadway Structures

The Contractor shall, at their own expense, provide suitable and safe temporary roadway structures, such as bridges and other crossings, where required for accommodation of travel. The Contractor shall provide access to private property during construction activities, and shall remove any temporary roadway structures thereafter.

11. Using Temporary Steel Plate Trench Bridging

The use of temporary steel plate trench bridging shall be governed by the requirements of the local municipality.

12. Managing Cut and Fill Materials

In general, and unless other material is indicated on Drawings or specified, material used for backfilling trenches and excavations around structures shall be material which was previously

removed while making the construction excavations. Excavated materials shall not be stockpiled on or within the travelled way.

Important: These excavated materials may be used only if they meet or exceed the Specifications for common borrow.

The nature of the excavated material will govern both its acceptability for backfill, and methods best suited for its placement and compaction in backfill. If sufficient suitable material is not available from the excavations, the backfill material shall be structural gravel, gravel aggregate, or common borrow as directed by the Owner's Representative.

13. Unsuitable Materials

Replacement materials for unsuitable materials shall be utilized only when directed by the Owner's Representative and shall be a clean dry porous gravel aggregate (NHDOT 304.2) or crushed stone. Materials shall be in accordance with local, municipal and NHDOT requirements.

D

SAFETY

The Contractor shall supply all necessary safety equipment for the work, including trench boxes, shields, vests, hard hats, ladders, and any additional safety-related equipment, instructions, and materials required to comply fully with all current State, Federal and local laws and ordinance regarding safety in excavation projects. The Owner's Representative may stop work at any time, without written notice, to correct safety violations and substandard conditions.

Note: Any losses incurred by the Contractor as a direct result of a work stoppage because of safety issues will be at the sole liability of the Contractor with no additional compensation forthcoming from the Owner.

E

PRODUCTS

All material, whether from excavations or from borrow, after being placed and properly compacted, shall make a dense stable fill that contains no vegetation, no individual roots more than 10 inches long

or more than ½ inch in diameter, no stones over 6 inches in diameter, or any porous matter. Organic matter of any type is not acceptable.

Refer to the appropriate Specification Sections for definitions of structural gravel aggregate for base and gravel aggregate for sub-base and around main and common borrow.

F

EXECUTION

1. Description

- a. The Contractor shall conduct their excavation operations, including any de-watering, sheeting, or bracing, in such a manner as to eliminate all possibility of undermining or disturbing foundations of existing structures or of work previously completed under this contract.
- b. The Contractor shall excavate to the width dimensions specified on the Drawings for laying and jointing piping, and furnishing and placing all sheeting, bracing, and supports. The Contractor shall conduct proper coffer dam operations, including pumping, draining, and rendering the bottom excavation surfaces firm, dry, and acceptable in all respects.
- c. The Contractor shall not use machinery to plow, scrape, or dig earth near to finished subgrade that may result in disturbance of any material below subgrade, unless indicated or specified. Before placing pipe, masonry, or other structures, any additional material to be excavated shall be carefully removed by hand with pick and shovel.
- d. The Contractor shall conduct all excavation operations in the open, except as otherwise specified or permitted.

2. Removing Pavement and Topsoil

- a. The Contractor shall remove only the amount of existing pavement that is necessary for prosecution of the Work.
- b. The Contractor shall carefully remove loam and topsoil from excavated areas and store these materials separately for further use or they must furnish equivalent loam and topsoil.

3. Installing Bracing and Trench Boxes

- a. The Contractor shall furnish, install, and maintain trench boxes, bracing, etc., as may be necessary to provide for personnel safety when working in the excavated area. This includes the prevention of any soil movement which could diminish the width of the excavation to less than that necessary for proper construction operations, proper support for the sides of the excavation, and the avoidance any conditions that could otherwise endanger adjacent structures, cause personnel injury, or delay work.

Important: All bracing and trench boxes shall comply with current OSHA requirements.

Neglect or improper implementation of bracing or trench boxes on the part of the Contractor may result in the Owner's Representative immediately stopping the progress of work. Any losses incurred by the Contractor as a direct result of a work stoppage because of bracing or trench box safety issues will be at the sole liability of the Contractor with no additional compensation forthcoming from the Owner.

- b. The Contractor shall carefully remove all sheeting and bracing not to be left in place so as not to compromise the construction operations or other structures. Voids left or caused by the withdrawal of sheeting shall be immediately backfilled using suitable materials as specified and properly compacted.

4. Drainage Discharge

- a. The Contractor shall provide and maintain suitable water pumping units and employ any other means necessary to intercept and/or promptly remove and properly dispose of all water entering trenches and other excavations. Excavations shall be kept dry until the pipes, appurtenances, and structures to be built therein have been completed to such an extent that they will not be floated or otherwise damaged by water intrusions. The Contractor shall have spare pumping units ready for immediate use in case of any unanticipated mechanical breakdowns.
- b. The Contractor shall dispose of all pumped or drained water without causing undue interference to other work, or damage to pavements, other surfaces, or property. The Contractor shall provide suitable temporary pipes, flumes, or channels for water that may flow along or across the work site. Drainage shall be discharged in accordance with all State and EPA regulations.

5. Trench Excavation Work

- a. The Contractor shall use machinery to excavate each trench to the specified subgrade. If material below the subgrade is significantly disturbed, the Owner's Representative may require the Contractor to compact the disturbed material before the placement of any backfill.
- b. The Contractor shall excavate trenches to the elevations indicated on Drawings, and at uniform slopes between indicated elevations. The Owner's Representative may modify the trench dimensions to accommodate field conditions as the work progresses.
- c. The Contractor shall excavate trenches per the Details indicated the Drawings with approximately vertical sides for pipes, unless otherwise specified. The Contractor shall not widen the pipe trench by scraping or loosening materials from the sides. They shall make every effort to ensure that the sides of trench remain firm and undisturbed until backfilling has been completed and consolidated.

6. Excavation Work near Existing Structures

When excavation operations occur near existing pipes, conduits, or other underground structures, the Contractor shall discontinue mechanical digging. Any additional material to be excavated shall be carefully removed by hand with pick and shovel. Manual excavation shall be included in work to be done, when incidental to normal excavation and under Items involving normal excavation.

7. Property Restoration

- a. The Contractor shall ensure that trees to be retained adjacent to the work site will not be injured by any excavation operations, especially their overhanging branches and limbs. The Contractor shall also ensure that materials and equipment are not stored adjacent to the work site such that trees are damaged.
- b. The Contractor shall ensure that all branches, limbs, and roots are cut smoothly and neatly, without splitting or crushing. Grafting wax or other types of tree healing paint shall be applied to injured cuts when directed.
- c. The Contractor shall ensure that cultivated hedges, shrubs, and plants to be retained on or adjacent to the work site will not be injured by any excavation operations. If necessary, hedges, shrubs, and plants shall be removed and properly stored and cared for. Once excavation operations are complete, they shall be replanted in their original locations and cared for until growth has been reestablished.

Hedges, shrubs, and plants that have been injured to such a degree that their growth has been curtailed or their beauty or usefulness have been diminished shall be replaced by the same

Items, equal in kind and quality. The vegetation at the work site shall be left in the condition that existed at the start of the work.

- d. The Contractor shall properly restore all surfaces which have been disturbed by their excavation operations to a condition at least equal to that in which they were found immediately before work commenced. Suitable materials and methods shall be used for such restoration.

8. Backfilling Excavations Made Beyond the Project Limits

If, during their operations, the Contractor takes the bottom of an excavation beyond the specified project limits, the excavation shall be backfilled with thoroughly compacted gravel aggregate to a minimum Proctor of 95% as required by *ASTM D1557*. Any losses incurred by the Contractor as a direct result of a work beyond the excavation limits will be at the sole liability of the Contractor with no additional compensation forthcoming from the Owner.

9. Disposing Surplus Excavated Materials

The Contractor shall use surplus excavated materials suitable for backfill to backfill pipe trenches in areas requiring “Common Borrow” as referenced by the Trench Details located on the Drawings. Excess excavated material must be properly disposed of by the Contractor, as previously approved, with no additional compensation forthcoming from the Owner.

10. General Backfilling Parameters

- a. The Contractor shall not use any frozen materials when conducting backfilling operations, nor shall they place backfill on any frozen material. Any previously frozen material shall either be removed and disposed of or properly thawed before any new backfill is placed.
- b. The Contractor shall place backfill material in maximum 12 inch lifts and compacted to the specified percent Proctor indicated on the Plans and in the Specifications. The Owner may test each lift to ensure that the specified level of compaction has been achieved, with the testing cost borne by the Owner.
- c. The Contractor shall use only suitable quantities of stones and rock fragments in backfill material. As part of the work done under the Items involving earth excavation and rock excavation as appropriate, they shall furnish and place all other necessary backfill material. The Contractor shall ensure that larger stones and lumps do not become “nested” and that all voids between stones are properly filled with fine material regardless of compacting method.
- d. The Contractor shall completely backfill all voids left by removal of sheeting with suitable backfill materials and ensure their proper compaction.

11. Placing and Compacting Pipe Trench Backfill Materials

- a. The Contractor shall start placing backfill as soon as practicable after the pipeline has been laid, and structures such as thrust blocks have had sufficient time to cure, and then proceed until backfilling operations are complete.
- b. The Contractor shall use mechanical rolling or tamping to compact the backfill above the zone around the pipeline in accordance with nature of the backfill material and the compaction requirements for the remainder of trench. The Contractor shall backfill the zone around the pipe with materials that adhere to the limits indicated on the Drawings, compacting the material to 95% Proctor as indicated on the Plans and in the Specifications.
- c. The Contractor shall deposit and spread backfill material in uniform parallel layers with a thickness not exceeding 12 inches when the material is to be compacted by tamping or rolling. Before next layer is placed, the new layer shall be tamped as required to obtain a thoroughly compacted mass. The Contractor shall ensure that the backfill material close to the bank, as well as in all other portions of trench, is thoroughly compacted. The Contractor may compact the backfill material using approved rollers, tractors, or similar powered equipment instead of tamping when the trench width and the depth allow their effective use without damaging or dislodging the pipeline.
- d. The Contractor shall wet backfill material by sprinkling with water when necessary to ensure its proper compaction by tamping or rolling. However, the Contractor shall conduct no compaction operations when the backfill material is too wet from either rain or over-application of water to be compacted properly. Work shall be postponed until new and previously placed materials have dried out sufficiently to permit proper compaction, or other actions have been implemented to obtain proper compaction.
- e. The Contractor shall not place stone or rock fragments larger than 6 inches in the backfill nor drop large masses of backfill material into the trench. Pieces of bituminous pavement shall not be permitted for use in backfill.
- f. The Contractor is required to backfill and compact the entire trench as part of the scope of work. If an issue such as a leaking pipe joint is discovered upon testing the pipe after the trench has been backfilled and compacted, it shall be the Contractor's responsibility to re-excavate, expose, and repair the leaking joint, and then backfill and compact the trench to the original Specifications. The Contractor shall consider this situation to be part of the "normal scope of work." Any losses incurred by the Contractor as a direct result of a work to re-excavate a trench will be at the sole liability of the Contractor with no additional compensation forthcoming from the Owner.

- g. The Contractor shall leave all bracing, trench boxes, and other safety measures in place until the Owner has satisfactorily completed compaction testing.

12. Placing and Compacting Embankment Materials

- a. Once the subgrade has been prepared as specified, the Contractor shall place and build up embankment materials in successive layers until the material has reached the required elevation.
- b. The Contractor shall place embankment materials in layers with a thickness not exceeding 12 inches before compaction and having a slight downward slope away from structures. In other embankments, layers shall be placed with a slight downward slope away from the center of the embankment. In general, finer and less pervious materials should be placed against structures or in the center, and coarser and more pervious materials to be placed on the outer parts of embankments.
- c. The Contractor shall compact each layer of embankment material using rollers or other approved means to secure a dense, stable, and thoroughly compacted mass. Places that cannot be reached by mobile mechanical equipment shall be compacted thoroughly by suitable power-driven tampers.
- d. The Contractor shall wet embankment material by sprinkling with water when necessary to ensure its proper compaction by tamping or rolling. However, the Contractor shall conduct no compaction operations when the embankment material is too wet from either rain or over-application of water to be compacted properly. Work shall be postponed until new and previously placed materials have dried out sufficiently to permit proper compaction, or other actions have been implemented to obtain proper compaction.
- e. The Contractor shall ensure that all other embankment materials are compacted to 95% Proctor as indicated on the Plans and in the Specifications.

PENNICHUCK WATER WORKS

[This page has been left intentionally blank]

SECTION 01500
Rock Excavation and Disposal

Table of Contents

A..... GENERAL
B..... RELATED WORK
C..... EXECUTION

A

GENERAL

Rock excavation work in ledge includes the removal of ledge and rock required for the installation of pipes and/or structures.

"Ledge" and "rock" includes any natural compound, natural mixture, and chemical element required to be excavated that, in the opinion of the Engineer, can be removed from its existing position and state only by blasting, drilling and blasting, wedging, drilling and wedging, wedging and breaking with power hand tools or pneumatic excavator attachment(s), or by extending the use of an approved excavating machine beyond normal and design wear and tear. No boulder, ledge, slab, or other single piece of excavated material less than one cubic yards in total volume shall be considered to be rock unless, in the opinion of the Engineer, it must be removed from its existing position by one of the methods mentioned above.

The Contractor shall furnish all labor, materials, tools, and equipment necessary to do all excavation of rock where encountered, and to ensure conformance with the lines and grades indicated on the Drawings or as directed. The Contractor shall properly dispose of the unsuitable excavated material and shall furnish acceptable material for backfill material in place of the excavated rock as specified.

Important: The Contractor is responsible for obtaining any permits required by local, State and Federal regulations in disposing of excavated material.

The Contractor shall excavate rock in pipe trenches to allow a clearance of not less than 12 inches from the bottom of the pipe and not less than 12 inches from each side of the pipe after it has been laid. Payment width shall be either 4 feet or the pipe diameter plus 24 inches, whichever is greater. Payment depth shall start at 12 inches below the bottom of pipe. Before the pipe is laid, the trench shall be backfilled to the correct subgrade with thoroughly compacted bedding material for pipe, furnished and placed at the Contractor's expense.

B

RELATED WORK

Section 01400 Earth Excavation, Backfill, Fill and Grading

Section 01525 Blasting

Section 01550 Vibration, Seismic, and Acoustic Monitoring

Section 01900 Gravel Aggregate for Road Base and Water Main Backfill

C

EXECUTION

Amount of Rock Excavation

The extent of open excavation shall be controlled by prevailing conditions. Open excavation shall always be confined to the limits acceptable to the Owner.

If the Contractor excavates rock beyond the limits of payment indicated on the Drawings, or otherwise specified or authorized in writing by the Owner's Representative, the excess excavation, whether resulting from overbreakage or other causes, shall be properly backfilled by the Contractor as specified under *Section 01400, Earth Excavation, Backfill, Fill, and Grading*. Any losses incurred by the Contractor as a direct result of a work beyond the rock excavation limits will be at the sole liability of the Contractor with no additional compensation forthcoming from the Owner.

Disposing of Rock

The Contractor shall properly dispose of all blasted and pneumatically removed rock at the Contractor's expense.

PENNICHUCK WATER WORKS

[This page has been left intentionally blank]

SECTION 01525

Blasting

Table of Contents

A..... GENERAL
B..... RELATED WORK
C..... EXECUTION

A

GENERAL

The Contractor shall furnish all labor, materials, tools, and equipment necessary to do all blasting and excavation of rock where encountered, and to ensure conformance with the lines and grades indicated on the Drawings or as directed. The Contractor shall provide all materials and perform all work necessary to ensure safe use and storage of explosives. The Contractor shall be responsible for any and all damage resulting from use of explosives. The Contractor shall properly dispose of the excavated material and shall furnish acceptable material for backfill material in place of the excavated rock as specified.

Important: Requirements of regulatory agencies shall always be met during blasting activities. Conduct all blasting in accordance with all applicable local, state, and federal laws, ordinances and code requirements.

B

RELATED WORK

Section 01400 Earth Excavation, Backfill, Fill and Grading

Section 01500 Rock Excavation and Disposal

Section 01550 Vibration, Seismic, and Acoustic Monitoring

Section 01900 Gravel Aggregate for Road Base and Water Main Backfill

C

EXECUTION

1. Pre-Blast Survey

The Blasting Contractor shall conduct a pre-blast survey and supply all equipment, labor, and materials necessary to drill and blast rock or to pneumatically remove the rock in accordance with all Federal, State, and municipality safety regulations and requirements.

2. Blasting Safety

- a. The Blasting Contractor shall keep explosives and explosives materials on-site only in such quantity as may be necessary for work under way and only during times that explosives are being used. The Owner's Representative shall be notified in advance of any plans to store and use explosives. Explosives shall be stored in a secure manner, separate from all other tools and equipment. Caps or detonators shall be stored in a secure place that is more than 100 feet away from the explosive storage area.

Once the explosives work has been completed, all remaining explosives material shall be promptly removed from the premises and work site.

- b. The Blasting Contractor shall observe all State, Federal, and municipal laws, ordinances, and regulations relating to the transportation, storage, handling, and use of explosives. If any of these laws, ordinances, or regulations requires a Licensed Blaster to perform or supervise the blasting work, they shall ensure that their license is on-site and available for examination thereof by the Owner's Representative or any other officials having jurisdiction.
- c. The Blasting Contractor shall conduct operations involving explosives with all possible care to avoid injury to persons and property. Blasting shall be done only with such quantities and strengths of explosives, and in such manner, as to break rock approximately at intended lines and grades, leaving rock to be excavated in an unshattered condition.
- d. The Blasting Contractor shall endeavor to avoid excessive cracking of rock upon or against which any structure will be built and prevent injury to existing pipes or other structure and property above or below ground during blasting operations. To avoid flying pieces of rock, rock shall be well-covered with mats where required.
- e. The Blasting Contractor shall provide sufficient warning to all persons in vicinity of the work before any charge is detonated.
- f. The Blasting Contractor shall identify the presence of any two-way radios, stray electrical currents, or other conditions that may adversely affecting blasting operations and implement necessary precautions to prevent accidents and premature blasts.
- g. The Contractor shall provide all appropriate signs and cones to ensure traffic safety in the blasting operations area and in accordance with the regulations found in the latest version of the NHDOT Standard Specifications for Road and Bridge Construction.

PENNICHUCK WATER WORKS

- h. The Contractor shall keep an accurate record of each blast, noting the general location of the blast, the number and depth of drill holes, the type and quantity of explosives used, and any other data that may be required. The Contractor shall submit all blast records to the Owner's Representative.
- i. Seismic monitoring of the blasting operations shall be conducted in accordance with all State and municipal regulations and requirements.

SECTION 01550

Vibration, Seismic, and Acoustic Monitoring

Table of Contents

A..... GENERAL
B..... RELATED WORK
C..... EXECUTION

A

GENERAL

The Contractor shall provide all materials and equipment to perform all work necessary to protect and prevent damage of existing structures due to vibrations generated from construction activities.

Where determined necessary by the Owner and/or Engineer, the Contractor shall monitor construction related vibrations and acoustic waves to avoid damaging nearby structures, properties, and utilities located on or near the project and prevent hazardous health conditions for persons in the vicinity of the work.

Sources of construction related vibrations include blasting activities, compaction equipment, hoe ram, sheeting, and other construction activities resulting in vibrations to adjacent properties and/or structures. The Contractor shall secure the services of a qualified Seismic, Vibration, and/or Acoustic Consultant who shall consult with the Contractor, to mitigate effects from vibration related to construction activities.

Contractor shall be responsible for any and all damage resulting from construction activity vibrations.

B

RELATED WORK

Section 01400 Earth Excavation, Backfill, Fill and Grading

Section 01500 Rock Excavation and Disposal

Section 01525 Blasting

Section 01900 Gravel Aggregate for Road Base and Water Main Backfill

C

EXECUTION

Prior to initiating any activity, which in the opinion of the Seismic/Vibration/Acoustic Consultant requires (or as directed by the Engineer or Owner), seismic, vibration, and/or acoustic monitoring, a Monitoring Plan shall be prepared by the Consultant and submitted to Contractor to support their methods of construction. The plan may be modified as work progresses based on monitoring results.

The Monitoring Plan shall identify:

1. Proposed construction activity
2. The anticipated seismic, vibration, and/or acoustic limits for the construction activity
3. Historic or significant structures of concern including structures in poor condition, structures supported by vibration sensitive materials which could cause settlement or loss
4. Procedures, techniques, and equipment to be employed by the Contractor to guard against damage to structures in the vicinity of the work area.

Seismic, vibration, and acoustic monitoring equipment shall meet the requirements of all local, state, and federal requirements and regulations.

The Contractor shall conduct a Pre-Construction Condition Survey of existing structures on the site identified in the Monitoring Plan including but not limited to brick and masonry structures, stone retaining walls and other sensitive areas. Further observation may be required at the discretion of the Contractor's Vibration Consultant or as directed by the Engineer or Owner. The completed Survey shall be provided to the Engineer or Owner as a written report.

The frequency and duration of monitoring for construction activities shall be identified in the Monitoring Plan.

Vibration Monitoring Reports shall be furnished to the Engineer upon request and shall include the following information:

1. The name of the Contractor and/or Subcontractors responsible for the particular construction activity.
2. The name of the approved Vibration Consultant.
3. The name of the operator of the vibration monitoring equipment.
4. A sketch indicating the location of the vibration monitors and the particular construction activity.

PENNICHUCK WATER WORKS

5. Results of monitored vibrations for the particular construction activity. This information should include the frequencies of the measured peak particle velocities.
6. Identification of any activity that caused the vibration limits to be exceeded and the time of day that the limits were exceeded.
7. A summary of related complaints received.

If the monitoring data indicates that the ground vibration limits for any of the three mutually perpendicular components or that acceptable human health acoustic levels have been exceeded, alternate construction methods will need to be considered by the Contractor to safeguard against damage to adjacent structures and/or human health. It will be the Contractor's responsibility to implement construction methods and techniques in a manner which will mitigate the effects of construction. Damage to existing structures or properties as a result of the Contractor's operations shall be resolved by the Contractor at no additional cost to the Owner.

The Engineer and/or Owner will notify the Contractor of any complaints concerning vibrations resulting from construction activities.

SECTION 01600

Water Main Pipe and Fittings

Table of Contents

A..... GENERAL
B..... RELATED WORK
C..... PRODUCTS
D..... PRODUCT DELIVERY, STORAGE, AND HANDLING
E..... EXECUTION
F..... TESTING

A

GENERAL

The Contractor shall furnish and install pipe and fittings as indicated on the Drawings and as detailed in the Specifications. Ductile iron pipe shall be specified for all projects unless otherwise indicated or approved by the Owner's Representative. Cast iron fittings shall not be used.

Important: PVC pipe, HDPE pipe, and ductile iron pipe, valves, fittings, gaskets and related materials not subject to the AIS requirements must be manufactured in North America, unless otherwise previously approved. Additional restrictions may apply due to issues with funding sources.

B

RELATED WORK

Section 01400 Earth Excavation, Backfill, Fill, and Grading

Section 01500 Rock Excavation and Disposal

Section 01525 Blasting

Section 01625 Polyethylene Encasement

Section 01900 Gravel Aggregate for Road Base and Water Main Backfill

Section 02400 Concrete Thrust Blocks

C

PRODUCTS

1. Ductile Iron Pipe

- a. Ductile iron pipe shall meet the requirements of American Water Works Association AWWA *C151/A21.51-91, American National Standard for Ductile-Iron Pipe, Centrifugally Cast, for Water or Other Liquids.*

PENNICHUCK WATER WORKS

- b. Ductile iron pipe shall be, at minimum, Thickness Class 52, zinc-coated.
- c. The exterior of the pipe shall be petroleum asphaltic-coated with a minimum of 4 mils dry film thickness over electro-deposited metallic zinc plating. The petroleum asphaltic coating shall be continuous, smooth, neither brittle when cold nor sticky when exposed to the sun, and strongly adherent to the fitting.

The zinc plating shall meet the requirements of *ISO 8179-1, Ductile iron pipes, fittings, accessories and their joints - External zinc-based coating - Part 1: Metallic zinc with finishing layer.*

The zinc plating shall be electro-deposited metallic zinc with a purity of 99.99%. The zinc plating shall be applied at a minimum thickness of 6 ounces per square yard.

Each segment of zinc-plated pipe shall be properly identified as such by the manufacturer.

- d. The nominal laying length of ductile iron pipe shall average no less than 18 feet per pipe section.
- e. The interior surfaces of ductile iron pipe shall be double-cement-mortar lined with a thickness of at least $\frac{1}{8}$ inch to meet the requirements of *AWWA C602, Cement-Mortar Lining of Water Pipelines in Place - 4 In. (100 mm) and Larger.*
- f. The interior surfaces of ductile iron pipe shall receive a 4-mil thick seal coating to meet the requirements of *AWWA C104.*
- g. Where required, ductile iron pipe and fittings shall be encased in Polyethylene to meet the requirements of *AWWA C105.* Refer to *Section 01625 Polyethylene Encasement* for more information.
- h. The Contractor shall provide sufficient quantities of fully-gauged ductile iron pipe to make all fitting nipples. The length of a ductile iron nipple must be 18 inches long or twice the pipe diameter, whichever is greater. Exception to this requirement must be approved by a representative from the Pennichuck Engineer Department prior to installation.
- i. The pipe manufacturer shall provide approved gaskets and gasket lubricants for push-on joint ductile iron pipe sections.
- j. The pipe supplier shall furnish two bronze wedges per pipe joint.

2. PVC Pipe

- a. PVC pipe shall meet the requirements of *AWWA C900*, Pressure Class 305 psi (DR 14).
- b. PVC pipe with push-on joints shall meet the requirements of *ASTM D3139, Standard Specification for Joints for Plastic Pressure Pipes Using Flexible Elastomeric Seals*.
- c. PVC pipe joint gaskets shall meet the requirements of *ASTM F477, Standard Specification for Elastomeric Seals (Gaskets) for Joining Plastic Pipe*.
- d. The nominal laying length of PVC pipe shall average no less than 20 feet per pipe section.
- e. The pipe manufacturer shall furnish approved gaskets and gasket lubricants for push-on joint PVC pipe sections.
- f. The Contractor shall use ductile iron mechanical joint compact fittings in the PVC piping run in all locations where couplings or bends are specified. Injection-molded PVC fittings shall not be used.
- g. The Contractor shall lay insulated 10-gauge solid core tracer wire and detectable warning tape in the trench at the top of the bedding sand above all PVC piping runs.

3. High Density Polyethylene Pipe (HDPE) Pipe

- a. HDPE pipe for water mains shall be Polyethylene (PE) 4710, DR 11 (200 psi rated); ductile iron pipe sized (DIPS). HDPE pipe shall meet the requirements of *NSF/ANSI Standard 61*.
- b. HDPE Pipe for water mains shall meet the requirements of *ANSI/AWWA C906, Polyethylene (PE) Pressure Pipe and Fittings, 4 In. Through 65 In. (100 mm Through 1,650 mm), for Waterworks*.
- c. All material shall be manufactured from a PE 4710 resin listed with the Plastic Pipe Institute as TR-4. The resin materials shall meet the specifications of *ASTM D3350* with a minimum cell classification of 445474C. HDPE pipe and fittings shall contain no recycled compounds except that generated in the manufacturer's own plant from resin of the same specifications. HDPE products shall be homogeneous throughout and free of visible imperfections.
- d. HDPE pipe shall be color-coded with a permanent blue stripe on the exterior of the pipe to designate its use for water.
- e. All HDPE joints must be made by a Fusion Technician trained and certified to use the equipment required to fuse the pipe size as specified for this project. The Certificate must be provided to Pennichuck prior to starting the project. Both butt fusion and electrofusion

equipment must be maintained and calibrated per their respective manufacture's requirements and recommendations.

- f. All HDPE fittings shall be made of HDPE material with a minimum material designation code of PE 4710 and meet the requirements of *AWWA C906*.
- g. The Contractor shall lay insulated 10-gauge solid-core tracer wire and detectable warning tape in the trench at the top of the bedding sand above all HDPE pipe.

4. Mechanical Joint Compact Fittings

- a. Mechanical joint compact fittings and solid sleeve couplings shall be Ductile Iron Class 350 (350 psi rated working pressure) and meet the requirements of *AWWA C153, Ductile-Iron Compact Fittings for Water Service* for fitting sizes of 3 inches to 24 inches in diameter inclusive.
- b. Acceptable coatings and lining combinations are as follows, in order of preference:
 - i. Fusion-Bonded Epoxy (FBE) – Fusion-bonded epoxy shall be used to coat exterior and interior surfaces and shall be applied at a minimum thickness of 8 mils. Fusion-bonded epoxy shall meet the requirements of *AWWA C116/A21.16-15* and *AWWA C550-17, Protective Interior Coatings for Valves and Hydrants*.

Fusion-bonded epoxy coatings shall be applied without defect.

- ii. Zinc Plated – The exterior of the pipe shall be petroleum asphaltic-coated with a minimum of 4 mils dry film thickness over electro deposited zinc plating. The petroleum asphaltic coating shall be continuous, smooth, neither brittle when cold nor sticky when exposed to the sun, and strongly adherent to the fitting.

ISO 8179-1, Ductile iron pipes, fittings, accessories and their joints - External zinc-based coating - Part 1: Metallic zinc with finishing layer

Fitting interiors shall be double-cement mortar-lined per the requirements of *ANSI/AWWA C104/A21.4-16, Cement-Mortar Lining for Ductile Iron Pipe and Fittings*. The cement mortar lining shall be seal-coated with a minimum thickness of 4 mils dry film in accordance with the requirements of *AWWA C104/A21.4-16*.

- c. The Contractor shall provide sufficient quantities of fully-gauged ductile iron pipe to make all fitting nipples.
 - d. All fittings shall be of Standard Grade 70-25-05 Ductile Iron construction with the following minimum characteristics: 70,000 psi minimum tensile strength; 50,000 psi minimum yield

strength; and 5% minimum elongation. Manufacturer's test results shall be made available upon request. Cast iron fittings shall not be used.

- e. The Contractor shall provide approved restrained gland assemblies for all fittings when connected to ductile iron pipe or "PVC restrainer glands or equivalent" unless otherwise specified.
- f. Solid sleeves shall be "long body" style without a pipe stop.
- g. SIP Industries fittings are approved for general use.

5. Mechanical Joint Resilient Wedge Gate Valves

- a. Approved mechanical joint resilient wedge gate valves shall include the following models for sizes 4 inches to 12 inches in diameter inclusive:
 - American Flow Control (AFC) - Model 2500
 - U.S. Pipe - Metroseal A-USP1
 - American AVK - Series 65
 - Mueller Co. - A-2361 or A-2362
 - Clow Valve Company – 2638
 - Kennedy Valve – AWWA C515 RWGV
 - M & H Valve Company – Style 7000

The use of any resilient wedge gate valves other than these requires prior written approval from Pennichuck Water Works.

- b. All mechanical joint resilient wedge gate valves from 4 inches through 12 inches diameter inclusive shall be the rubber-seated bubble tight-closing type and shall meet the requirements of *AWWA C515, Reduced-Wall, Resilient Seated Valves For Water Supply Service*.
- c. All external fasteners on mechanical joint resilient wedge gate valves shall be ASTM 18-8 Stainless Steel Type 304
- d. All mechanical joint resilient wedge gate valve bodies shall be coated on both the interior and exterior surfaces with a two-part thermoset epoxy cover to a nominal thickness of 10 mils.

- e. All ductile iron mechanical joint resilient wedge gate valve stems shall be non-rising and equipped with operating nuts that are 2-inch square. The opening direction for hydrants and valves is dependent on the particular municipality in which they are installed. Refer to *Appendix A, Hydrant and Valve Opening Direction* for more information.
- f. All resilient wedge tapping valves used in mechanical joint tapping shall be capable of accepting a full-size tapping cutter.
- g. All resilient wedge tapping valves shall conform to the *AWWA C515, Reduced-Wall, Resilient Seated Valves For Water Supply Service* with the exception that one end of the valve shall be flanged and one end shall be a mechanical joint.

6. Mechanical Joint Butterfly Valves

- a. Butterfly valve manufacturers considered by Pennichuck Water Works shall have a minimum of five years of experience in the manufacture of butterfly valves for the size and type of service as required in these Specifications.
- b. Approved mechanical joint butterfly valves shall include the following models for sizes 16 inches through 36 inches in diameter inclusive:
 - Henry Pratt Company – Pratt Groundhog
 - Clow Valve Company – Style 4500
 - M & H Valve Company – Style 4500
 - Kennedy Valve – Style 4500
 - Mueller Company - Mueller Linesal XPII
 - VSI Waterworks – AWWA Series BFI Butterfly Valve
 - Val-matic Valve and Mfg Corp - American – BFV Butterfly Valve

The use of any resilient wedge gate valves other than these requires prior written approval from Pennichuck Water Works.

- c. All mechanical joint butterfly valves from 16 inches through 72 inches diameter inclusive shall be the rubber-seated tight-closing type and shall meet the requirements of *AWWA C504, Rubber-Seated Butterfly Valves, 3 In. (75 mm) through 72 In. (1,800 mm)* or *AWWA C519, High Performance Water Works Butterfly Valves, 3 In. (75 mm) through 72 In. (1,800 mm)*

PENNICHUCK WATER WORKS

- d. All mechanical joint butterfly valves must use the full AWWA C504, Class 150B valve shaft diameter and full Class 250 underground service operator torque rating throughout the entire travel to provide capability for emergency service operation.
- e. All ductile iron mechanical joint butterfly valve bodies shall conform to the requirements of AWWA C111/A21.11-17, *Rubber-Gasket Joints for Ductile-Iron Pressure Pipe and Fittings*.
- f. All mechanical joint butterfly valves shall be equipped with operating nuts that are 2-inch square. The opening direction for hydrants and valves is dependent on the particular municipality in which they are installed. Refer to *Appendix A, Hydrant and Valve Opening Direction* for more information.
- g. All mechanical joint butterfly valve bodies shall have integral hubs for housing shaft bearings and seals.
- h. All mechanical joint ends shall conform to the requirements of AWWA C111/A21.11-17.
- i. All butterfly valve discs shall be of the “off-set” design to provide a full 360° seating surface uninterrupted by shaft holes. There shall be no external ribs to the flow.
- j. Ductile Iron butterfly valve bodies and valve discs shall be constructed of Grade 65-45-12 Ductile Iron that meets the requirements of *ASTM A53/A53M, Standard Specification for Pipe, Steel, Black and Hot-Dipped, Zinc-Coated, Welded and Seamless*. Cast Iron butterfly valve bodies and valve discs shall be constructed of Cast Iron that meets the requirements of *ASTM A126 Class B Standard Specification for Gray Iron Castings for Valves, Flanges and Pipe Fittings*. Non-metallic butterfly valve discs shall not be used in any Pennichuck Water Works projects.
- k. All resilient seats shall be Buna-N or natural rubber designed to provide tight shutoff at the specified pressures. The rubber seat may be on the disc edge or in the valve body but in either case, must be retained by positive mechanical means with corrosion-resistant hardware.
- l. Resilient seats must be capable of mechanical adjustment in either direction without the use of special tools and be capable of complete replacement in the field without chipping, grinding, or burning out the old seat or its retaining mechanism. The rubber mating surface in all cases must be, at minimum, 300 Series Stainless Steel.
- m. All mechanical joint butterfly valve shafts shall be of single piece “through” type construction. The shafts shall be fabricated from round stock, 18-8 Stainless Steel Type 304 material.
- n. All mechanical joint butterfly valve assemblies shall be furnished with a single two-way thrust bearing designed to center the disc in the body at all times and absorb thrust forces. The drive end shaft shall be of the cartridge type with O-rings to provide positive sealing.

- o. All mechanical joint butterfly valves shall be tested per *AWWA C504-10*, including hydrostatic, performance, and leakage tests.
- p. All ductile iron or cast iron components of mechanical joint butterfly valves shall have their internal and external surfaces coated with a high performance, one-part, heat-curable, thermosetting epoxy coating that has a minimum thickness of 9 mils, except for furnished bearing surfaces. This epoxy coating material shall meet the requirements of *NSF/ANSI Standard 61: Drinking Water System Components – Health Effects*.
- q. All mechanical joint butterfly valve actuators shall be integrally mounted on the valve mounting flange and shall be of the self-locking traveling nut type in accordance with *AWWA C504*.
- r. All external fasteners on mechanical joint butterfly valves shall be ASTM 18-8 Stainless Steel Type 304

7. Couplings

- a. Approved couplings shall include these from the following manufacturers:
 - Romac Industries, Inc. Alpha Couplings
 - Romac Industries, Inc. Macro HP Couplings
 - Romac Industries, Inc. 501 Couplings
 - Romac Industries, Inc. XR 501 Couplings
 - Romac Industries, Inc. 400 Couplings, with $\frac{3}{8}$ inch wall thickness \times 10 inches long center ring
 - Ford Meter Box Co. FC2A Couplings
 - Ford Meter Box Co. FC2W Couplings
 - Mueller Co. Maxi-Range Couplings
 - JCM Industries Model 203 Transition Couplings
 - JCM Industries Model 215 Couplings
 - JCM Industries Model 241 Couplings
 - JCM Industries Model 242 Couplings

PENNICHUCK WATER WORKS

- b. Couplings with limited approval shall include these from the following manufacturers:
- Viking Johnson QuickFit Couplings
 - Viking Johnson MaxiFit Couplings
 - Viking Johnson MegaFit Couplings
 - Krausz USA HYMAX Couplings
 - Krausz USA HYMAX 2 Couplings
 - Krausz USA HYJOINT Couplings
- c. All couplings listed in this subsection shall be manufactured in North America. **Couplings with limited approval must be approved by Pennichuck Engineering for use in advance and on a case-by-case basis.**
- d. Couplings must be *NSF/ANSI Standard 61* approved for use with potable water supplies and meet the requirements of *AWWA C219*.
- e. The coupling body length shall be equal to or longer than the nominal diameter of the pipe, but in no case shall be less than 6 inches in length.
- f. Coupling bodies shall be fabricated from Ductile Iron Grade 65-45-12 or Steel Grade ASTM A53.
- g. Coupling bodies shall have a coating of fusion-bonded epoxy or Nylon 11.
- h. End rings shall be fabricated from Ductile Iron Grade 65-45-12 or Steel Grade ASTM A283.
- i. End rings shall have a similar coating as the coupling body or have an thermoset epoxy coating.
- j. Couplings with bituminous coatings, primer coatings, or “shop” coatings shall be fully encased in Polyethylene after installation.
- k. Nuts and bolts shall be stainless steel or high-strength, low-alloy steel that meets the requirements of *ANSI/AWWA C111/A21.11, Standard for Rubber-Gasket Joints for Ductile Iron Pressure Pipe and Fittings*. High-strength, low-alloy steel nuts and bolts shall receive a corrosion-inhibiting coating.
- l. All gaskets used in the coupling assembly shall be Virgin SBR (Styrene Butadiene Rubber) for water service in accordance with the requirements of *ASTM D2000 MBA 710*.

8. Ductile Iron Mechanical Joint Tapping Sleeves

- a. All mechanical joint tapping sleeves shall be mechanical joint split sleeves with an outlet flange that meets the requirements of *AWWA C110, Sections 10 – 14*.
- b. All mechanical joint tapping sleeves shall be of ductile iron construction and include a ¾ inch F.I.P. threaded test plug so that both the sleeve and valve can be pressure-tested before any tap is made.
- c. All mechanical joint tapping sleeves up to a size of 12 inches × 12 inches shall be rated for a minimum working pressure of 200 psig.
- d. All side rubber gaskets used in mechanical joint tapping sleeves shall be rectangular in cross-section and fit into grooved channels in the casting. These gaskets shall extend the entire length of the sleeve and shall not require cutting or trimming to match mechanical joint end gaskets.
- e. All mechanical joint tapping sleeves shall be furnished with standard accessories, including glands, gaskets, and “T” head bolts and nuts as described elsewhere in these specification or their equivalent. All flange bolts shall be Type 316 stainless steel.
- f. Exterior surfaces shall be petroleum asphaltic coating applied at a minimum thickness of 4 mils dry film. The petroleum asphaltic coating shall be continuous, smooth, neither brittle when cold nor sticky when exposed to the sun, and strongly adherent to the fitting.
- g. Interior surfaces shall be double-cement mortar-lined per the requirements of *ANSI/AWWA C104/A21.4-16*. The cement mortar lining shall be seal-coated with a minimum thickness of 4 mils dry film in accordance with the requirements of *AWWA C104/A21.4-16*.
- h. All ductile iron mechanical joint tapping sleeves shall be encased in Polyethylene. Refer to *Section 01625 Polyethylene Encasement* for more information.

9. Stainless Steel Tapping Sleeves

- a. Stainless steel tapping sleeves are allowed for use on ductile iron pipe if the diameter of the tap is one-half the diameter or less of the existing pipe.
- b. Stainless steel tapping sleeves are allowed for use on pre-1930s cast iron pipe 16 inches or 24 inches in diameter if the diameter of the tap is one-half the diameter or less of the existing pipe.
- c. Stainless steel tapping sleeves shall have either a stainless steel or ductile iron flange. If a ductile iron flange is used, it shall receive a factory-applied enamel coating.

- d. Stainless steel tapping sleeves shall be rated for a minimum working pressure of 200 psig.
- e. All lugs, bolts, nuts, washers, lifter bars, and armor for stainless steel tapping sleeves shall be fabricated from Type 304 Stainless Steel.
- f. Stainless steel tapping sleeves shall meet the requirements of *NSF/ANSI Standard 61*.
- g. Stainless steel tapping sleeves shall feature an included ¾ inch FIP threaded test plug for pressure testing purposes.

10. Steel Tapping Sleeves for 16-inch and 24-inch Asbestos Cement Pipe

- a. Steel tapping sleeves shall be Romac Industries, Inc., FTS425 Fabricated Steel Tapping Sleeves.
- b. Steel tapping sleeves are allowed for use on 16-inch diameter and 24-inch asbestos cement pipe.
- c. Steel tapping sleeves shall meet the requirements of *NSF/ANSI Standard 61*.
- d. As steel tapping sleeves are fabricated to order, the Contractor shall verify the outer diameter of the existing asbestos cement pipe.
- e. Bolts and nuts for steel tapping sleeves shall be high-strength low-alloy steel that meets the requirements of *AWWA C111*.
- f. Steel tapping sleeves shall be lined with a fusion epoxy coating that is 8 to 12 mils in thickness.
- g. Flanges shall be AWWA Class D plate flanges, ANSI Class 150.

11. Valve Boxes and Covers

- a. All valve boxes shall be grey cast iron, two-piece sliding type with a top flange and a minimum inside shaft diameter of 5 inches.
- b. The bottom section of the valve box shall be 48 inches long, unless otherwise specified on the Drawings, and provided with a belled (buffalo) base. The top section of the valve box shall be 26 inches long and designed to slide over the base section.
- c. Refer to *Standard Detail M14* for more information.
- d. All valve box covers shall be castiron, non-tilting heavy 2-inch drop-type. Valve box covers shall be recessed in the box top to prevent any snowplow damage. Valve box covers shall

feature two pick holes to facilitate easy removal and the word “WATER” shall be cast to properly identify them.

- e. All valve box components shall be generously coated with a corrosion-resistant bituminous coating.
- f. All valve box components shall be manufactured in North America.

12. Megalug Style Mechanical Joint Restraints

- a. Megalug style mechanical joint restraints shall be one of the following types, or their equivalent:
 - EBAA Iron - Megalug® *Series 1100* for Ductile Iron pipe
 - EBAA Iron - Megalug® *Series 2000PV* for PVC pipe
 - Ford Meter Box Company – Uni-flange® Pipe Restraint Series 1559 for PVC pipe
 - Ford Meter Box Company – Uni-flange® Pipe Restraint Series 1500 for PVC and HDPE pipe
 - Ford Meter Box Company – Uni-flange® Wedge Action Restraint Series 1400
 - SIP Industries – EZ Grip® Joint Restraint for Ductile Iron Pipe
 - SIP Industries – EZ Grip® Joint Restraint for PVC Pipe
- b. Megalug style mechanical joint restraints shall be used in conjunction with all mechanical joint fittings mated to ductile iron and PVC pipe unless otherwise specified. Megalug style mechanical joint restraints shall be installed in place of MJ glands.

Important: Joint flexibility must be retained after the jointing operations have been completed.
- c. Megalug style mechanical joint restraints shall be cast ductile iron and meet the requirements of *ASTM A536-84, Standard Specification for Ductile Iron Castings*.
- d. Megalug style mechanical joint restraints shall permit proper clearance for the use of standard MJ Bell, “T” head bolts, and hardware. Reference Section 01600.c.16 on approved bolts and hardware.
- e. Megalug style mechanical joint restraints shall be designed to accommodate up to 250 psi of working pressure with a 2:1 safety factor.

- f. Megalug style mechanical joint restraints shall employ torque limiting twist-off nuts to ensure proper actuation of the restraining lugs.
- g. All Megalug style retainer glands must be coated with a thermoset epoxy cover to a nominal thickness of 10 mils.

13. Grip Ring® Pipe Restraints

- a. Grip Ring® pipe restraints shall be manufactured by EBAA Iron or its equivalent and shall be used in conjunction with all MJ fittings mated to PVC pipe unless otherwise specified.
- b. Grip Ring® pipe restraints shall be cast ductile iron and meet the requirements of *ASTM A536-84*.

Important: Joint flexibility must be retained after the jointing operations have been completed.

- c. Grip Ring® pipe restraints shall be installed in place of MJ glands.
- d. Grip Ring® glands shall be used as recommended by the restraint manufacturer and painted yellow to differentiate them from Standard MJ glands.

14. Foster Adaptor™

- a. Infact Corporation Foster Adaptor™ MJ restraint is approved for use on a conditional basis. Use of a Foster Adaptors™ must be approved for each location in advance of their use on MJ fittings and valves.
- b. All Foster Adaptors™ shall be manufactured in North America.
- c. Foster Adaptor™ restraints shall be installed in place of MJ glands, megalugs, griprings or any other pipe restraint method.
- d. Foster Adaptors™ shall be manufactured of ductile iron and meet the ductile iron and pressure specifications of *ANSI/AWWA C153/A21.53 AND C110/A21.10*.
- e. The Foster Adaptor™ shall be supplied with an NSF 61, 7-mil. fusion bonded epoxy coating conforming to *AWWA C116/A21.16-09* as well as the coating, surface preparation and application requirements of *ANSI/AWWA C550*.
- f. Foster Adaptors™ shall be provided with hardware in accordance with Section C part 16 of these specifications.

15. Hydrants

- a. Hydrants shall be one of the following types:
 - Mueller Co. Super Centurion 250™ with A-423 5¼ inch Valve
 - AMERICAN Flow Control 5¼ inch Waterous Pacer® WB67-250 with 16 inch upper standpipe length
 - U.S. Pipe Metropolitan® M94 with 5¼ inch Main Valve.
 - Clow Medallion with 5 1/4 inch Main Valve
- b. All hydrants shall be configured to be buried to a depth of 6 feet.
- c. All hydrants shall have working drain holes, breakaway flanges, and 1½ inch pentagonal operating nuts. The opening direction for hydrants and valves is dependent on the particular municipality in which they are installed. Refer to *Appendix A, Hydrant and Valve Opening Direction* for more information.
- d. All hydrants shall be factory-primed and coated with an approved yellow finish.
- e. All hydrants shall be ULFM approved.

16. “T” Head bolts and Miscellaneous Hardware

- a. All “T” Head bolts, bolts, washers and nuts shall be one of the following or approved equivalent;
 - Trumbull Stainless Steel “T” Head Bolts and Nuts Type 304 or Type 316 Stainless Steel
 - Trumbull Cor-Blue™ coated “T” Head Bolts and Nuts
 - Romac R-blue – Xylan coated “T” Head Bolts and Nuts.
- b. The use of any “T” head bolts other than these requires approval from Pennichuck Water Works.
- c. All stainless steel fasteners, bolts, “T” head bolts, nuts, threaded rod, rod couplings and washers are to be Type 304 stainless steel or Type 316 stainless steel
- d. Low alloy high strength cold rolled steel bolts, “T” head bolts, rod couplings, nuts and washers are acceptable if they are coated with either:

PENNICHUCK WATER WORKS

- a baked on ceramic filled fluorocarbon resin
 - zinc base coated with an overcoat of Xylan 1424.
 - Hot dipped zinc galvanized
 - Other coatings with advanced approval and review by the engineer.
- e. Bolts and “T” head bolts shall feature roll formed threads and meet or exceed all ANSI/AWWA C111/A21.11 and C115/A21.15 requirements.
- f. Pigtails, also known as “eye bolts”, “tie bolts” or “MJ eye bolts” shall be made with type 304 stainless steel or a low alloy steel in accordance with ANSI/AWWA C111/121 with one of the following corrosion inhibiting finishes if available:
- a baked on ceramic filled fluorocarbon resin
 - zinc base coated with an overcoat of Xylan 1424.
 - Hot dipped zinc galvanized
 - Other coatings with advanced approval and review by the engineer.

17. Fire Services

- a. Fire Services may be constructed of ductile iron, PVC, or HDPE piping only if the piping is in accordance with Section 01600.C.1, 01600.C.2, and 01600.C.3, respectively, and all piping beneath the building, the riser into the building, and the underground piping 18 feet from the edge of the building shall be ductile iron.

D

PRODUCT DELIVERY, STORAGE, AND HANDLING

- a. All pipe shall be shipped to the work site in stacks cushioned by work separators such that pipe-to-pipe contact is prevented during the transit and storage of the pipe. Once delivered to the work site, all pipe shall be stacked in a safe and acceptable manner.
- b. The Contractor shall ensure that care is taken during the loading, trucking, unloading, and handling of all pipe and fittings so as not to damage the materials or surrounding area. Pipe and fittings shall not be dropped directly from the truck to the ground. The Contractor assumes responsible for any pipe or fittings damaged during delivery, handling, or storage. All damaged materials shall be removed from the work site immediately.
- c. Pipe sections may not be placed in position along the line of work unless approved by the Owner's Representative. Pipe and fittings must be stored in such a manner that they do not obstruct any roadways, driveways, sidewalks, etc.
- d. The Contractor shall keep all materials in the right-of-way with written permission from the municipality or on private property with written permission from the property owner.
- e. Pennichuck Water Works is not responsible for any agreements made between the Contractor and private land owners.

E

EXECUTION

1. Assembling Push-on Joint Pipe Runs

The Contractor shall assemble push-on joint pipe runs in strict observance with the manufacturer's instructions as follows:

- a. Thoroughly clean any dirt or foreign material from the groove and bell socket and insert the gasket, verifying that the gasket faces the proper direction and is correctly seated.

PENNICHUCK WATER WORKS

- b. Thoroughly clean any dirt or foreign material from the plain end and apply lubricant that meets the requirements of *NSF/ANSI Standard 61* in accordance with the pipe manufacturer's recommendations.
 - i. **Note:** The lubricant is supplied in sterile cans and every effort shall be made to keep it sterile.
- c. Verify that the plain end of the pipe is beveled; as square or sharp edges may damage or dislodge the gasket and cause leakage. When pipe is cut in the field, the plain end shall be beveled with a grinder to remove all sharp edges.
- d. Push the plain end into the bell of the pipe, keeping the pipe straight while pushing. Any allowable deflection from the pipe alignment may be made after the joint is assembled. Two bronze wedges shall be inserted at each joint.
- e. A timber header should be used between the pipe and jack or backhoe bucket to avoid any damage to the pipe.
- f. The cleanliness of each pipe section must be maintained at all times during assembly. The Contractor shall prevent any dirt or foreign material from entering the pipe while it is being placed in the trench. No debris, tools, clothing, or any other material shall be allowed to be placed in the pipe at any time.
- g. As each pipe section is placed in the trench, it shall be properly connected to the previous pipe section and the pipe run brought to correct line and grade.
- h. Pipe shall be laid with the bells facing the direction in which work is progressing.
- i. To avoid infiltration with any water, dirt, or foreign material, pipe sections that have an open end exposed when work is not in progress shall be closed with a temporary watertight pipe plug or by other means approved by Pennichuck Water Works. If the trench is inundated, the Contractor shall ensure that pipe flotation does not occur and that pipe plugs remain in place until the trench has been dewatered.
- j. When it is necessary to deflect the pipeline from a straight line in either the horizontal or vertical plane, the amount of deflection shall not exceed 80% of the maximum allowable deflection as specified by the manufacturer. Since deflections are cumulative in the horizontal and vertical planes, allowable typical cumulative pipe deflection allowances shall also be made based on the pipe manufacturer's Specifications.

- k. The Contractor shall install air release valves as detailed on the Drawings at all high points on the pipeline, or as otherwise directed by the Owner's Representative. If a high point on the pipeline is created by the Contractor at a point other than those designated on the Drawings, installation of an air release valve must be approved by the Owner's Representative for payment purposes. Air release valves shall be installed at the end of all "dead end" water mains.

2. Installing Mechanical Joint Fittings

- a. All mechanical joint fittings shall be inspected prior to installation to ensure the gasket seats are free of excess coating. The Contractor shall manually remove any excess coating to ensure that the gasket will seal properly. All bare metallic surfaces exposed as the result of removing the excess coating shall be re-coated with similar material to prevent any corrosion.
- b. The Contractor shall install "compact" fittings as required in the "Mechanical Joint Fittings" Subsection for all fittings sizes from 3 inches to 24 inches.
- c. All mechanical joint fittings shall be placed, supported, and installed in strict accordance with the manufacturer's instructions and as directed by Pennichuck Water Works.
- d. After bolted connections in the mechanical joint have been made finger tight, the Contractor shall tighten diametrically opposite nuts in the joint progressively and uniformly around the joint with a properly calibrated torque wrench to the manufacturer's recommended values as specified above.
- e. The Contractor shall ensure that all back-up bends, tees, and other mechanical joint fittings subject to movement from internal pressures are properly braced by precast concrete thrust blocks that are in turn supported by compacted gravel aggregate unless otherwise specified. Refer to *Section 02400, Precast Concrete Thrust Blocks* of these Specifications for more information. Refer also to standard thrust block details on the Drawings for more information.
- f. The Contractor shall ensure that all mechanical joint fittings separated by pipe lengths of less than 10 feet shall be restrained by an appropriate number of ¾ inch to 1 inch diameter stainless steel threaded rod and nut assemblies as directed by the Owner's Representative. Unless otherwise restrained with threaded rods as specified, each MJ shall be installed with Megalug or PVC grip ring retainers.

Table 1600A – Mechanical Joint Fitting Restraints

Pipe Size (in)	No. of Rods	Rod Diameter (in)
10 or less	2	¾
12 – 16	4	¾
24 or more	4	1

- g. The maximum allowed deflection per mechanical joint shall not exceed the limits indicated in the manufacturer’s Specifications.

3. Installing Mechanical Joint Resilient Wedge Valves and Butterfly Valves

- a. The Contractor shall ensure that all resilient wedge and butterfly valve bodies are installed with their operators plumb and level.
- b. The Contractor shall ensure that all resilient wedge and butterfly valve joints are assembled following the installation requirements outlined in the “Mechanical Joint Fittings” Subsection. All joint bolts shall be torqued using a calibrated torque wrench in accordance with the manufacturer’s Specifications.
- c. The Contractor shall ensure that the fusion-bonded epoxy coated exterior is not damaged. Any damaged areas shall be repaired by the contractor in accordance with the manufacturer’s recommendation, at the sole expense of the Contractor.
- d. The Contractor shall ensure that all resilient wedge and butterfly valves are restrained by means of stainless steel threaded rod and nut assemblies to the nearest fitting if the length of pipe between the valve and the fitting is less than 10 feet. The Contractor shall use Megalug retainer glands if the length of pipe is greater than 10 feet. Refer to *Table 1600-A – Mechanical Joint Fitting Restraints* for more information.
- e. The Contractor shall ensure that all resilient wedge and butterfly valves are installed complete with valve box and cover. Valve boxes and covers shall be installed following the guidelines in “Installing Valve Boxes and Covers” Subsection. Refer to standard valve box and cover details on the Drawings for more information.

4. Installing Ductile Iron Couplings

- a. The Contractor shall install ductile iron couplings in strict accordance with the manufacturer's instructions.
- b. Before installing ductile iron couplings, the Contractor shall descale and clean the end of each ductile iron pipe section, with the cleaned area extending 12 inches from the end.
- c. The Contractor shall begin the ductile iron coupling installation process by slipping the follower and gasket over the pipe to 6 inches from the end, and then placing the middle ring on the pipe end until it is centered over the joint. The Contractor shall use reference marks to determine the exact center location.

5. Installing Tapping Sleeves and Valves

- a. The Contractor shall install all tapping sleeves and valves in strict accordance with the manufacturer's instructions. The Contractor shall pressure-test all tapping sleeves and valves before beginning tapping operations.
- b. The Contractor shall ensure that tapping sleeves are installed such that the flanged face of the sleeve is plumb.
- c. The Contractor shall ensure that all tapping sleeves subject to movement from internal pressures are properly braced by precast concrete thrust blocks that are in turn supported by compacted gravel aggregate unless otherwise specified. Refer to *Section 02400, Precast Concrete Thrust Blocks* of these Specifications for more information. Refer also to standard thrust block details on the Drawings for more information.
- d. The Contractor shall ensure that the outlet of the valve is made up in accordance with the manufacturer's Specifications and that the valve is installed in accordance with the standard valve installation detail on the Drawings.
- e. The Contractor shall use the type of gland on the outlet end of the valve specified on the Drawings.
- f. The Contractor shall ensure that all body bolts are tightened to the torque values specified by the manufacturer.
- g. The Contractor shall retain the section of cut pipe, or coupon, that results from the tapping operation and submit it to the Owner's Representative.

6. Installing Valve Boxes and Covers

- a. The Contractor shall ensure that all valve boxes are installed such that they are concentric to the operating nut and plumb. The belled base section shall be placed on blocking in such a way that no additional loading is transferred to the valve.
- b. The Contractor shall ensure that longer valve box bottoms and/or tops are specified as required for water mains installed at depths that exceed the limitations of the valve box.
- c. The Contractor shall ensure that all valve boxes located in traveled ways are left flush with the pavement or gravel shoulder unless otherwise specified. Valve boxes located in other non-paved areas shall be left flush with finish grade unless otherwise specified.
- d. Extension rings shall not be used for adjusting new gate boxes to the proper grade.

7. Installing Megalug Style Mechanical Joint Restraints

- a. The Contractor shall ensure that all megalug style mechanical joint restraints are installed in accordance with the manufacturer's Specifications and with "Megalug Style Mechanical Joint Restraints" Subsection.
- b. Once the megalug style gland has been made up, proceed to tighten the twist-off lugs on the restraining lugs in a diametric pattern, twisting the lugs until each one is in contact with the pipe before completing the tightening process. Tighten the heads in a diametric pattern until all the twist-off heads have been removed.

8. Installing Hydrants

- a. The Contractor shall ensure that all hydrants are installed as shown on the Drawings and in the Standard Details.
- b. The Contractor shall ensure that all hydrants are installed such that they are plumb.
- c. The Contractor shall ensure that all hydrants are installed with their traffic safety flange located from 4 inches to 6 inches above the finished grade surrounding the hydrant.
- d. The Contractor shall ensure that all hydrant bases are installed in a 3 foot × 3 foot × 3 foot cube of 1½ inch crushed stone to allow for the free drainage of any water leaking from the hydrant's drain hole. A layer of 6-mil Polyethylene sheeting or geotechnical fabric shall be laid on the surface of the stone before completing the backfilling of the hydrant.

9. Installing PVC Grip Ring® Restrainers

- a. Before installing PVC grip ring retainers, the Contractor shall bevel and clean the end of each PVC pipe section.
- b. The Contractor shall begin the installation of PVC grip ring retainers by sliding the gland, grip ring, and MJ gasket on to the end of the pipe, verifying that the tapered side of the grip ring faces the gland.
- c. Next, insert the pipe end into the MJ fitting and slide the gasket into the MJ socket as far as possible. The gland and grip ring may be used to tap the gasket into the socket if necessary.
- d. Slide the grip ring up the pipe until its face is against the MJ gasket, then slide the gland up the pipe until it engages the grip ring.
- e. Install “T” head bolts in the MJ fitting and gland, then hand-tighten all the nuts.
- f. Using a torque wrench, tighten the nuts in a star pattern to the manufacture’s recommended torque value. Wait ten minutes after tightening the last bolt and then re-torque the bolts.

F

TESTING

1. Conducting Pressure and Leakage Testing

- a. The Contractor shall hire an approved independent certified testing company to perform pressure and leakage testing in accordance with the applicable AWWA Standards and Specifications. It is the sole responsibility of the Contractor to obtain the testing results from the testing company and submit the results to Pennichuck Water Works for each section of water main tested.

Important: All water mains, appurtenances, and hydrant branches shall be pressurized by the testing company to a minimum of 1½ times the normal working pressure of the water main or 150 psi, whichever is greater, for at least 2 hours.

Allowable Leakage rate shall be calculated using the following formula:

$$L=SD\sqrt{P} \div 1040.625$$

L = Allowable Leakage, ounces per **hour**

S = Length of Pipe tested, feet

D= Nominal Pipe Diameter, inches

P= Average Test Pressure During Leakage Test, psi

- b. If a section of water main piping fails pressure and leakage testing, the Contractor shall locate, uncover, and repair or replace the defective section of pipe, fitting, valve, or joint at no additional expense to the Owner and without any time extension. The testing company shall then conduct additional testing until satisfactory test results are achieved.
- c. If the water main is not used for distributing water to customers for a period of 12 months or more, the Contractor shall be responsible to perform the pressure and leakage testing again prior to PWW accepting the water main.
- d. Applicable to Developer projects, reference the Main Extension Agreement for pressure and leakage testing requirements.

2. Conducting Flushing and Disinfection Operations

The testing company shall conduct flushing and disinfection operations using methods and procedures that meet the requirements of *AWWA C651, Standard for Disinfecting Water Mains*. All costs associated with flushing and disinfecting the water main shall be borne by the Contractor.

Samples from the disinfected water main shall be taken by the testing company for bacteriological analysis. If the testing company determines that the sample results indicate high bacteria levels, they shall immediately inform the Contractor and the Owner's Representative. The testing company shall then perform additional flushing and disinfection operations until subsequent test samples indicate safe bacteria levels.

Any additional flushing and disinfection operations by the testing company shall be conducted at the Contractor's expense.

The Contractor shall install suitable taps at the end of the disinfected water main to enable the collection of samples for bacteriological testing. The Contractor shall remove these taps and plug the water main with brass corporation plugs upon the successful completion of the disinfection operations and verification by Pennichuck Water Works.

PENNICHUCK WATER WORKS

If the water main is not used for distributing water to customers for a period of 12 months or more, the Contractor shall be responsible to conduct flushing and disinfection operations again prior to PWW accepting the water main.

Applicable to Developer projects, reference the Main Extension Agreement for flushing and disinfection operations' requirements.

Best Practices for Discharging Chlorinated water:

- a. Potable water containing chlorine shall be discharged directly into a sanitary sewer manhole or storm drain. The discharge event shall not cause a surcharge or disrupt sewer service. Please consult with the local Sewer Treatment facility prior to discharging into their system.
- b. It is recommended that when a sanitary sewer or storm drain manhole is not available, water should be dechlorinated using chemical or non-chemical methods. Testing is recommended throughout the discharge event to ensure chlorine levels are within acceptable range. Care shall be taken to avoid discharging directly into wetlands, vernal pools, stream beds, and other vulnerable environments.

PENNICHUCK WATER WORKS

[This page has been left intentionally blank]

SECTION 01625
Polyethylene Encasement

Table of Contents

A..... GENERAL
B..... RELATED PRODUCTS
C..... PRODUCTS
D..... EXECUTION

A

GENERAL

The Contractor shall furnish and install Polyethylene encasement at all locations specified, or as directed by the Owner.

B

RELATED WORK

Section 01600 Water Main Pipe and Fittings

Section 01650 Water Service/Air Release Materials

C

PRODUCTS

1. Polyethylene Encasement Materials

- a. The Contractor shall supply Polyethylene encasement film in tubular or sheet form. The Polyethylene film shall meet the requirements of *AWWA C105, Polyethylene Encasement for Ductile-Iron Pipe Systems*. The film shall be free of tears, breaks, holidays, or defects. The film shall also have a 2.5% to 3.0% carbon black content, either low or high-density.
- b. Low-density Polyethylene film shall be manufactured from virgin Polyethylene material that meets the following requirements of *ASTM D4976, Standard Specification for Polyethylene Plastics Molding and Extrusion Materials*:
 - Group 2 (Linear)
 - Class C (Black)
 - Density: 0.910 to 0.935 g/cm³
 - Dielectric Volume Resistivity: 10¹⁵ ohm-cm (min.)

PENNICHUCK WATER WORKS

Low-density Polyethylene film shall have the following physical properties:

- Tensile Strength: 3,600 psi (min.)
 - Elongation: 800% (min.)
 - Dielectric Strength: 800 V/mil thickness (min.)
 - Thickness: 0.008 inch, nominal
- c. High-density, cross-laminated Polyethylene film shall be manufactured from virgin Polyethylene material that meets the following requirements of *ASTM D4976*:
- Group 2 (Linear)
 - Class C (Black)
 - Density: 0.940 to 0.960 g/cm³
 - Dielectric Volume Resistivity: 10¹⁵ ohm-cm (min.)

High-density, cross-laminated Polyethylene film shall have the following physical properties:

- Tensile Strength: 6,300 psi (min.)
 - Elongation: 100% (min.)
 - Dielectric Strength: 800 V/mil thickness (min.)
 - Thickness: 0.004 inch, nominal
- d. Polyethylene tape used to join sheets of Polyethylene film shall be 3 inches wide (minimum 2 inches) plastic-backed adhesive tape. The adhesive material shall be suitable for long-term contact with Polyethylene film without damaging it.

D

EXECUTION

1. Preparing to Install Polyethylene Encasement

- a. The Contractor shall ensure that the pipe and valve surfaces that are to receive Polyethylene encasement are clean and free of any soil, mud, clay, cinders, or other foreign materials before any encasement operations are started.

The Contractor shall also ensure that no foreign materials are inadvertently trapped between the pipe and the Polyethylene film during the process.

- b. The Contractor shall ensure that the Polyethylene film is applied to the contour of the pipe to affect a snug but not tight fit with minimum space between Polyethylene film and the pipe. The Contractor shall allow sufficient slack in the contouring to prevent stretching the Polyethylene film where it bridges irregular surfaces such as bell spigot interfaces, bolted joints, or fittings. Overlaps and end joints shall be secured with Polyethylene adhesive tape to hold the Polyethylene encasement in place until backfilling operations have been completed.

Important: All efforts shall be made to prevent damage to the Polyethylene film due to backfilling operations.

- c. For water main installations below the water table or in areas subject to tidal action, the Contractor shall ensure that both ends of the Polyethylene tube are properly sealed with Polyethylene adhesive tape at the overlap joint.

2. Installing Polyethylene Encasement

a. Tubular Polyethylene (Method A)

- i. The Contractor shall cut the Polyethylene tube to length approximately 2 feet longer than the pipe section. Slip the tube around the pipe, centering it to provide a 1 foot overlap on each adjacent pipe section, and then bunching the film tube “accordion” fashion lengthwise until it clears the pipe ends.
- ii. Lower the pipe section into the trench and make a pipe joint with the preceding section of pipe. Make shallow bell holes at the joints to facilitate installation of the Polyethylene tube.
- iii. After assembling the pipe joint, make an overlap of Polyethylene tube. Pull bunched Polyethylene film from the preceding length of pipe, slip it over the end of the adjoining

length of pipe and then secure it in place. Slip the end of the Polyethylene from the adjoining pipe section over the end of the first wrap until it overlaps the joint end of the preceding pipe, and then secure the overlap in place. Take up the slack width at the top of the pipe to make a snug, but not tight, fit along the barrel of the pipe, securing the fold with Polyethylene tape at quarter points along the length of the pipe.

- iv. Repair any cuts, tears, punctures, or other damage to the Polyethylene film, and then proceed with installation of the next section of pipe in the same manner.

b. Tubular Polyethylene (Method B)

- i. The Contractor shall cut the Polyethylene tube to length approximately 1 foot shorter than the pipe section. Slip the tube around the pipe, centering the tube to provide 6 inches of bare pipe on each end. Take up the slack width at the top of the pipe to make a snug, but not tight, fit along the barrel of the pipe, securing the fold with Polyethylene tape at quarter points along the length of the pipe.
- ii. Before making up the joint, slip a 3-foot length of Polyethylene film tube over the end of the preceding pipe section, bunching it in “accordion” fashion lengthwise along the pipe. After assembling the joint, pull the 3-foot length of Polyethylene film over the joint, overlapping the Polyethylene previously placed on each adjacent section of pipe by at least 1 foot. Make each end snug and secure.
- iii. Repair any cuts, tears, punctures, or other damage to the Polyethylene film, and then proceed with installation of the next section of pipe in the same manner.

c. Polyethylene Sheet

- i. The Contractor shall cut the Polyethylene sheet to length approximately 2 feet longer than the pipe section. Center the length to provide 1 foot overlap on each adjacent pipe section, bunching the sheet until it clears the pipe ends. Wrap the Polyethylene sheet around the pipe so that the sheet circumferentially overlaps the top quadrant of the pipe, and then secure the cut edge of the Polyethylene sheet at 3-foot intervals.
- ii. Lower the wrapped pipe into the trench and make up the pipe joint with the preceding section of pipe. Make a shallow bell hole at the joints to facilitate installation of the Polyethylene. After completing the joint, make the overlap and secure the ends.

d. Pipe-shaped Appurtenances

The Contractor shall ensure that all bends, reducers, offsets, and other pipe-shaped appurtenances are properly encased in Polyethylene film in the same manner as pipe sections.

e. Odd-shaped Appurtenances

The Contractor shall ensure that valves, tees, crosses, and other odd- shaped appurtenances, which may not be encased using tube type Polyethylene, are properly wrapped with flat sheet Polyethylene film and split lengths of Polyethylene tubing by passing the sheet around the appurtenance and encasing it. Make seams by bringing the edges together, folding them over twice and then taping them down. Tape Polyethylene securely in place at valve stems and other penetrations.

f. Encasement Openings

The Contractor shall ensure that encasement openings for branches, service taps, blow offs, air valves, and similar appurtenances added after the pipe has been installed are made by making an X-shaped cut in the Polyethylene and temporarily folding back the film. After the new appurtenance is installed, any slack in the film shall be taped securely to the appurtenance. Any cuts, as well as any other damaged areas in the Polyethylene, shall be properly repaired with Polyethylene tape. Service taps may also be made directly through the Polyethylene, with damaged areas being repaired as specified.

g. Junctions between Wrapped and Unwrapped Pipes

The Contractor shall ensure that when joining Polyethylene encased pipe to adjacent pipe that is not wrapped, the Polyethylene wrap is extended to cover the adjacent pipe for a distance of at least 3 feet. Ends shall be secured with circumferential turns of the tape. Service lines of dissimilar metals shall be wrapped with Polyethylene film or suitable dielectric tape for a minimum clear distance of 3 feet away from cast or ductile iron pipe.

3. Repairs

The Contractor shall ensure that any cuts, tears, punctures, or damage to Polyethylene film are repaired with adhesive tape or with a short length of Polyethylene sheet, wrapped around the pipe to cover the damaged area, and properly secured in place.

SECTION 01650

Water Service and Air Release Materials

Table of Contents

A..... GENERAL
B..... RELATED PRODUCTS
C..... PRODUCTS
D..... EXECUTION
E..... TESTING

A

GENERAL

The Contractor shall furnish and install all water service replacements and reconnections as indicated on the Drawings and as detailed in the Specifications. All service line fittings shall be brass or copper, and all brass and copper parts in contact with water shall be designated lead-free with less than 0.25% lead content. All water service and air release materials must be manufactured in North America.

B

RELATED WORK

Section 01400 Earth Excavation, Backfill, Fill and Grading

Section 02100 Sand

C

PRODUCTS

1. Copper Tubing

- a. All copper tubing shall be Type “K” and meet the requirements of AWWA C800.
- b. Copper tubing in 1 inch size shall be of the soft, coiled type and shall conform with the requirements of ASTM B88, *Standard Specification for Seamless Copper Water Tube*. Copper tubing for 1 1/2 inch and 2 inch copper tubing shall be supplied in straight lengths.
- c. The Contractor shall install detectable warning tape in the trench 18 inches to 24 inches below finished grade above all copper tubing runs.

2. Polyethylene Tubing

- a. HDPE pipe for water services shall meet the requirements of ANSI/AWWA C901, *Polyethylene (PE) Pressure Pipe and Tubing, 3/4 In. (19 mm) Through 3 In. (76 mm), PE445574C CC3, and SDR9*.

- b. Where the use of Polyethylene tubing is permitted, it shall be Copper Tubing Sized (CTS) and rated for a working pressure of 200 psi. **1 inch diameter polyethylene tubing can only be used with prior written approval from the Pennichuck Engineering department.**
- c. The Contractor shall lay insulated 10-gauge solid-core tracer wire in the trench at the top of the bedding sand above all Polyethylene tubing runs. Detectable warning tape shall be installed 18 inches to 24 inches below finished grade.
- d. Polyethylene tubing shall be reinforced with stainless steel insert reinforcements where fittings are attached to the Polyethylene tubing.
- e. Only approved brass compression-style fittings shall be used in conjunction with Polyethylene tubing.

3. Corporation Valves

- a. The Contractor shall install corporation valves that meet the requirements of *NSF/ANSI 61 Certification* and *AWWA C800*.

Approved corporation valve manufactures include the following:

- Mueller Co.® 300™ Ball Type Corporation Valves, with Mueller Co. 110 Compression Connection fittings
- Ford Meter Box Co. Ballcorps and Corporation Stops [Ford w/ “T” Compression Nut]
- Cambridge Brass™ Corporation Stops
- A.Y. McDonald Manufacturing Co. Corporation Valves

Corporation valves from other manufacturers must be pre-approved for use by Pennichuck Water Works.

- b. The Contractor shall ensure that all corporation valves have a Teflon-coated brass ball stop and are rated for a working pressure of 300 psi.
- c. The Contractor shall ensure that all corporation valves have a CC inlet thread and a copper pack joint compression outlet.
- d. Plug-style corporation valves shall not be used.

4. Curb Stops

- a. The Contractor shall install curb stops that meet the requirements of *NSF/ANSI 61 Certification* and *AWWA C800*.

Approved curb stops manufactures include the following:

- Mueller Co. 300™ Ball Curb Valves, with Mueller Co. 110 Compression Connection fittings
- Ford Meter Box Co. Ball Valve Curb Stops [Ford w/ “T” Compression Nut]
- Cambridge Brass Curb Stops and Meter Valves, with Series 202 Compression Couplings
- A.Y. McDonald Manufacturing Co. Curb Stops

Curb stops from other manufacturers must be pre-approved for use by Pennichuck Water Works.

- b. The Contractor shall ensure that all curb stops have a Teflon-coated quarter turn brass ball stop and are rated for a working pressure of 300 psi.
- c. The Contractor shall ensure that all curb stops open “left” and feature a ¼ turn stop.
- d. The Contractor shall ensure that all curb stops have no drain holes.
- e. Plug-style curb stops shall not be used.

5. Service Saddles

- a. The Contractor shall install service saddles that meet the requirements of *AWWA C800*. Approved service saddle manufactures include the following:

- Mueller Co. DR2S, Epoxy-coated, double stainless steel strap
- Ford Meter Box Co. FCD202, Epoxy-coated, double stainless steel strap
- Romac Industries, Inc. Style 202NS, Nylon-coated, double stainless steel strap
- Smith-Blair Model 317, Nylon-coated, double stainless steel strap

Service saddles from other manufacturers must be pre-approved for use by Pennichuck Water Works.

- b. The Contractor shall ensure that all saddles are provided with a female CC thread.

6. Service Boxes

- a. The Contractor shall install service boxes that are arch style (“Erie”) pattern with a 5-foot to 6-foot slide-type adjustable riser, unless otherwise specified on the Drawings. Service boxes shall have a minimum I.D. of 1 inch.
- b. The Contractor shall ensure that all service boxes are supplied with a plug-style cover. The cover shall be cast or ductile iron and shall screw onto the service box riser. The cover shall have “WATER” integrally cast into the cover. The plug shall be cast bronze or brass with a “rope” thread.
- c. The Contractor shall ensure that all service boxes are furnished with a Type 304 Stainless Steel service box rod, ½ inch diameter by 30 inches long. A brass or stainless steel cotter pin shall be provided to secure the service box rod to the curb stop.
- d. The Contractor shall ensure that all service boxes are coated with a bituminous coating that meets the requirements of *AWWA C110, Ductile-Iron and Gray-Iron Fittings*.

7. Brass Goods

- a. The Contractor shall ensure that all brass goods meet the requirements of *NSF/ANSI Standard 61*.

Approved brass goods manufactures include the following:

- Mueller Co.
- Ford Meter Box Co. (T-style)
- A.Y. McDonald Manufacturing Co.
- Cambridge Brass

Brass goods from other manufacturers must be pre-approved for use by Pennichuck Water Works.

- b. The Contractor shall ensure that all brass goods are supplied with iron pipe threads or compression couplings.
- c. The Contractor shall ensure that all brass goods are rated for a minimum working pressure of 150 psi.

D

EXECUTION

1. Installing Copper Tubing

- a. The Contractor shall ensure that all copper tubing water services are bedded in at least 6 inches of sand, above and below the tubing.
- b. The Contractor shall ensure that all copper tubing is installed with brass compression fittings unless otherwise detailed on the Drawings.
- c. The Contractor shall ensure that all copper tubing is installed without the occurrence of any kinks or egg-shaped anomalies. If any kinks or egg-shaped anomalies are found, the Contractor shall remove that particular section of copper tubing and then properly repair it. The Owner’s Representative shall have the final decision on any issues that may arise regarding the installation of copper tubing.
- d. Underground soldered fittings shall not be used.
- e. The use of crimping tools on copper tubing shall not be permitted.

2. Installing Compression Couplings

The Contractor shall ensure that all compression couplings are installed and tightened in accordance with the manufacturer’s recommendations, with care taken to prevent over-tightening.

3. Installing Corporation Valves

- a. The Contractor shall ensure that corporation valves are installed on all water services at the service tap into the water main.
- b. The Contractor shall ensure that properly-sized corporation valves that are directly tapped into ductile iron water mains meet the size requirements specified in the following table:

Table 1650A – Water Mains and Tap Sizes

Tap Size (in)	Main Size (in)
1	6 and larger
2	12 and larger

- c. The Contractor shall ensure that all corporation valves that cannot be directly tapped into ductile iron water mains instead shall be tapped through a tapping saddle. On 2-inch PVC pipe, 2-inch copper tubing, or 2-inch HDPE pipe the Contractor shall cut in a FIP Brass Tee with a compression fitting.

4. Installing Curb Stops

- a. The Contractor shall ensure that all curb stops are installed with a curb box assembly and rods as specified.
- b. The Contractor shall ensure that all curb stops are installed inside the municipal ROW within 1 foot of the edge of the ROW, or as close as is possible
- c. The Contractor shall ensure that all curb stops are installed plumb.
- d. The Contractor shall ensure that all curb stops are set upon pressure-treated wood blocking measuring 2 inches × 6 inches × 12 inches or upon a flat rock with similar dimensions.

5. Installing Service Boxes

- a. The Contractor shall ensure that all service box bases, placed on the same blocking or flat surface as the curb stop, are centered over the curb stop and are plumb.
- b. The Contractor shall ensure that all service box tops are flush with the existing finished grade.
- c. The Contractor shall ensure that all service boxes installed in sidewalks, drives, or pavement are installed inside a gate box top.

E

TESTING

1. Conducting Pressure Tests

- a. The Owner's Representative shall conduct a thorough visual inspection of all newly-placed water services after the Contractor has completed their installation work and before any backfill operations begin.
- b. The Contractor shall ensure that all corporation valves, curb stops, and couplings are left exposed for monitoring as the pressure test proceeds.

PENNICHUCK WATER WORKS

- c. The Contractor shall conduct the pressure test by filling and pressuring the system to the specified rating and visually inspecting each fitting, valve, hydrant, cap, and plug along the system to verify that no leakage has occurred.
- d. If the water service is not used for distributing water to customers for a period of 12 months or more, the Contractor shall be responsible to conduct flushing and disinfection operations again prior to PWW accepting the water service.
- e. Applicable to Developer projects, reference the Service Application Agreement for testing requirements.

SECTION 01660

Cleaning and Lining – Cast Iron Water Mains

Table of Contents

A..... GENERAL
B..... RELATED PRODUCTS
C..... PRODUCTS
D..... EXECUTION
E..... TESTING

A

GENERAL

The Contractor shall furnish all materials, equipment, incidental items and labor necessary to completely clean and line cast iron water mains indicated on the drawings and as detailed within the specifications.

The work shall consist of excavating access holes, shoring, covering and dewatering access holes, making pipe openings, cleaning and lining the water mains, restoring the pipe openings, pressure testing and chlorination, backfilling, and trench restoration.

B

RELATED WORK

Section 01400	Earth Excavation, Backfill, Fill and Grading
Section 01600	Ductile Iron Water Main and Fittings
Section 01680	Temporary Water Mains and Services
Section 02700	Measurement and Payment

C

PRODUCTS

1. Cement – Mortar

- a. All cement-mortar for cast iron water mains shall be composed of Portland Cement, sand and water. The cement-mortar shall be proportioned by volume and shall be mixed and of the proper consistency to provide a dense, homogenous water main lining that shall adhere firmly to the interior wall of the water main. **The cement-mortar shall have a compressive strength of not less than 5,000 psi at 28 days.**

- b. Cement-Mortar shall be mixed in proportions of one part Portland Cement to one to one and one half parts of sand by volume. The exact proportions shall be determined by the characteristics of the sand used. The mortar shall be well mixed and the water-cement ratio shall be carefully controlled and kept to a minimum. No mortar which has attained its initial set shall be used for pipe lining. To improve the qualities of density, durability, insolubility and surface smoothness, a natural cement may be required and will be used in the proportion of one bag of natural cement to 5 bags of Portland Cement.
 - i. Sand - Sand shall be washed, cleaned, well graded and free from organic matter. 100% of the sand shall pass the No. 16 screen and no more than 5% shall pass the No. 100 sieve. Sand shall conform to Section 2.4 of AWWA C602-89 standard for Cement-Mortar Lining of Water Pipelines-4 In. (100mm) and Larger- In Place.
 - ii. Cement – The cement shall conform to the requirements of ASTM C150 for Type II cement. The cement shall be free of lumps and the residue on a standard No. 200 sieve shall not exceed 10% by weight.
 - iii. Water - Water shall be obtained from Pennichuck Water Works water supply.

2. Epoxy

- a. The coating system shall be a solids epoxy monolithic surfacing system for use in coating existing potable water mains. All products to be used on this project must be pre-approved by the Engineer prior to the bid date.
- b. The coating system shall meet all requirements in the following specifications:
 - i. ANSI/AWWA C620-07 – Spray-Applied in-place Epoxy Lining of Water Pipelines, 3 in. (75mm) and Larger
 - ii. NSF/ANSI 61 – Drinking Water System Components – Health Effects

D

EXECUTION

1. Phasing

Work on the cleaning and lining shall be phased in accordance with the plans and the special conditions section of these specifications. The intent is to divide the cleaning and lining into phases such that is compatible with the temporary bypass schemes for each street. A new cleaning and lining phase cannot be initiated until the previous phase has been completed and permanent service restored to the previous phase.

2. Valve Operations

- a. The Owner shall be responsible for **operating** all valves necessary to effect the required cleaning and lining work. **The Contractor shall provide the Owner with three (3) working days notice of each required valve operation associated with the cleaning and lining.**
- b. In the event that the Owner is unable to completely shut off the flow of water into the section of water main to be cleaned and lined it shall be the responsibility of the Owner to determine which valves are leaking by. **The Contractor will be responsible for replacing the leaking valves via a change order issued by the Owner.**

3. Excavation

- a. The Contractor shall complete access hole excavations in accordance with section 01400 of these specifications. The completed access hole excavations shall be shored to stabilize the excavation walls and prevent collapse of the traveled way into the excavation. All shoring shall comply with OSHA regulations.
- b. The Contractor shall provide steel plating to cover all access holes. The plating shall be of sufficient size and thickness to permit normal traffic to pass over the covered access holes. The Contractor shall properly secure the steel plating to the road surface and shall place a cold patch or asphalt ramp at the plate edges in order to produce a smooth transition from the existing roadway onto and off of the steel plating. Steel plating shall be flat with no more than 1" runout permitted between plate corners.

4. Dewatering

- a. Before initiating the cleaning and lining process, the Contractor shall dewater all pipe lines and access holes, drain all low spots and take all necessary precautions to prevent water from entering the main section being worked on. The Contractor shall insert bulkheads at the terminals of the dewatered sections.
- b. The trench shall be protected from wash and rainwater as is necessary to keep water out of the water main being cleaned and lined until the cleaning and lining is completed.

5. Obstructions

- a. In the event obstructions are encountered during the water main cleaning that preclude the passage of the cleaning and lining equipment then the Owner will authorize the Contractor, via the change order process, to locate and remove the obstructions.

6. Cleaning of Water Mains

- a. All rust, tubercles, deposits, loose materials and all other foreign materials shall be removed from the interior of the pipe lines by use of water propelled cleaning devices or other approved methods. The Contractor shall pass the machine through the mains as many times as may be necessary and to employ such other supplementary means as may be required to clean the pipe surfaces and to remove all foreign matter, rust and dust from the pipe surfaces. It shall be the responsibility of the Contractor to employ approved methods and to do all work necessary to obtain clean pipe surfaces and to insure the satisfactory bonding of the cement-mortar lining to the pipe surfaces. The Contractor shall be responsible for locating and restarting the cleaning unit if it should become lodged in the pipe.
- b. Branch connections and service connections shall be backflushed to remove all sediment, loose and foreign material which have entered the branch lines during cleaning operations. Precautionary measures shall be provided to protect valves and other appurtenances against the entrance of dirt, sediment and other foreign materials and any other damage. All damage to valves, pipes or other pipe line appurtenances and fittings as a result of the Contractor's operations shall be made good or replaced by the Contractor in a manner satisfactory to the Engineer, at no additional expense to the Owner; defective parts, not the result of the Contractor's operations will be repaired by and at the discretion of the Owner.
- c. After the cleaning operations, the Contractor shall make an examination of the interior of the pipes, in a satisfactory manner, to determine whether the pipes have been sufficiently and properly cleaned so as to assure the proper bonding and placing of the lining and to determine whether any repairs to the pipes are required, prior to the application of the lining. The Contractor shall provide such facilities as may be required for inspection of pipes by the Owner. If the examination and inspection reveals that the cleaning operations have not been satisfactorily performed, the Contractor, at no additional expense to the Owner, shall provide all other additional cleaning work as may be necessary for the proper installation of the lining and as required. No defective section or part shall be lined until repairs have been made and approved by the Engineer.

7. Cement-Mortar Lining of Water Mains

- a. Cement-mortar lining of water mains shall not be started until all cleaning operations have been satisfactorily completed and all defective water main fittings and appurtenances has been satisfactorily repaired or replaced. The first ten (10) feet of each section of pipe shall be cleaned and cement-mortar lined in accordance with the requirements, the Owner shall immediately inspect the cement-mortar for adequate thickness and continuity. If the lining is deemed to meet the specifications then the lining process shall proceed. If the lining process is deemed inadequate, then the cement-mortar will be washed out and reapplied until the application meets the specifications.

- b. The cement-mortar lining in the pipe lines shall be continuous, dense, smooth and without variations in quality, and free from noticeable changes in thickness. The cement-mortar lining of the pipe line shall be troweled in accordance with specifications set forth by, and under the direction of the Engineer.
- c. The cement-mortar lining thickness for the pipe lines shall be 1/8-inch minimum thickness with an allowable plus tolerance of 1/16-inch. **No minus tolerance in the cement-mortar lining thickness specified will be permitted.**
- d. Installation of Cement-Mortar Pipe Lining.
 - i. Immediately prior to running the lining machine through the pipe line, all sand, water, loose material and all other foreign material that has accumulated in the pipe lines shall be satisfactorily removed.
 - ii. The cement-mortar pipe lining shall consist of a one-course application of a pre-mixed cement-mortar and shall be continuously placed by a machine projecting the mortar against the wall of the pipe by centrifugal force, without injurious rebound, and with sufficient velocity to cause the mortar to be densely packed and to adhere in place. Pneumatic methods for placing cement-mortar will not be permitted. The travel of the machine and the rates of discharge of mortar shall be controlled so as to produce a uniform homogenous thickness of lining around the perimeter and along the length of the pipe line. Hand placing of the mortar lining shall not be permitted, except where machine placing is impossible or impracticable and so approved by the Engineer. The machine used for cement-mortar lining the pipe shall be provided with attachment for mechanically troweling the mortar so as to produce a smooth surface finish, and shall travel ahead of the lining so that the freshly placed and troweled mortar will not be touched until it has set; the design of the trowel attachment shall be such as to permit operation in pipes which may be found out of round, and produce a smooth surface without spiral shoulders. The finished surface shall be smooth and shall not have a sand finish.
 - iii. Mortar which does not provide a dense, homogenous lining which will adhere to the pipe surfaces, sand pockets, voids, oversanded and cracked areas, and such other defective areas and materials shall be removed to the pipe wall, and the areas shall be repaired by hand application or other approved method to the full required thickness of the mortar lining and as approved. All spatter and loose material shall be removed from the pipe lines.
 - iv. Troweled finished surfaces shall be tested for finish and 9 out of 10 places checked shall conform to the tolerance for finished surfaces. The waste materials shall be removed from the pipe ahead of the trowels. Lack of homogeneity will not be permitted. The Contractor shall make frequent determinations of the thickness of the lining as placed in order to maintain proper control of application. The cement-mortar lining shall nowhere be less than 1/8-inch and should be no greater than 3/16-inch. If any section of the lining shall show irregularity or shall require an excessive amount of

hand patching, or otherwise fail to meet these specifications, the faulty section of the lining shall be removed to the extent directed by the Engineer, the pipe recleaned, and the lining replaced by the above method at the Contractor's expense.

Note that this includes thin sections which shall be scraped off and redone with the machine.

Cables shall be sheathed at the ends of the pipe at all times.

- v. Service lines less than 2" in diameter shall be backflushed with water or air before the cement-mortar lining has set, to result in each service line having a full opening with no obstructions. Any service found to be obstructed with cement or debris shall be excavated, cleared, repaired, backfilled and pavement restored (if necessary) by the Contractor and at the Contractor's expense.

e. Curing of Cement-Mortar Lining

Immediately upon completion of the cement-mortar lining of pipe line between pipe openings or upon the completion of day's run of the machine, the section of the pipe line shall be closed at each end. As soon as practicable after placing the cement-mortar lining, water shall be introduced into the mortar lined section between the closed ends of pipe in order to create a moist atmosphere and keep the cement-mortar lining damp, but not under pressure, until the mortar lining has been in place not less than 48 hours. The Contractor shall be responsible for the proper curing of the cement-mortar linings.

f. Hand Mortar Work

Cement-mortar lining of sharp bends, specials, areas adjacent to valves, or other areas where machine placing is impracticable, and correcting defective areas, shall be done by hand. Hand placed mortar shall have uniformly smooth finished surfaces and with smooth transitions adjacent to machine placed areas. Cement-mortar shall be as specified herein for machine lining. Prior to the placing of hand mortar work, all areas to be lined shall be thoroughly cleaned in an approved manner with all loose and foreign materials removed and if required, surfaces shall be dampened before placing the mortar. Steel trowels shall be used for finishing where practicable. Hand mortar work shall be completed within 24 hours after machine application in that particular section of pipe line has been completed. Machine application of mortar lining shall be slowed down, or stopped, if necessary, to assure hand mortar work being placed in accordance with the requirements specified or directed.

g. Protection of Lining

The Contractor shall take every precaution to prevent injury to the pipe lining. All damage to pipe linings shall be satisfactorily repaired, or damaged portions removed and replaced to the satisfaction of the Engineer.

h. Inspection and Testing of Cement-Mortar

- i. The Contractor shall make a set of three (3) test cylinders of the cement-mortar used for pipe linings for every 1000 feet of water main that is lined. The making, curing, handling and testing of cement-mortar shall be in accordance with A.S.T.M. Specifications and as approved; the making, handling, curing and testing of mortar test cylinders shall be performed by the Contractor. The testing of mortar test cylinders will be as follows:
 - a. One cylinder tested at seven (7) days, one cylinder tested at twenty-eight (28) days, one cylinder held as a spare.
 - b. All test results shall be submitted to the Owner within one (1) week of completion.
 - c. Cylinder tests to be completed by an independent testing agency approved by the Owner.
- ii. The machine for placing the cement-mortar lining shall be so operated and controlled as to produce pipe linings conforming to the requirements specified herein. The operation and controls for the equipment shall be constantly checked while the machine is in operation.

i. Guarantee of Cement-Mortar Lining

The Contractor shall guarantee all materials and workmanship, furnished under this Contract, against deterioration and failure for a period of 1 year after final acceptance of all the work under this Contract. Any portion of the cement-mortar lining found to be deteriorated or to have failed shall be made good by the Contractor in a satisfactory manner by patching or by removal and replacement of the cement-mortar lining, as required by the Engineer, to provide a sound, durable cement-mortar lining. Repairs or replacements shall be made in accordance with the requirements specified herein, including removal of defective lining, cleaning the pipe, cutting and repairing or replacing access openings and other incidental work. Repairs or replacements of defective cement-mortar lining shall be provided by the Contractor at no additional expense to the Owner.

8. Epoxy

a. Installer Qualifications

- i. All products must be installed by an Installer that has been trained and certified by the manufacturer. The installer shall provide verifiable documentation of the above certification.

b. Quality Assurance

- i. Applicator shall initiate and enforce quality control procedures consistent with applicable ASTM standards.
- ii. Applicator shall use an adequate number of skilled workmen who are thoroughly trained and experienced in the necessary crafts. These workmen shall be completely familiar with the specified requirements and the methods needed for proper performance of the work of this Section.
- iii. Applicator shall use approved specialty equipment adequate in size, capacity and number sufficient to accomplish the work of this Section in a timely manner.

c. Application

- i. The cured surfacing shall be monolithic with proper sealing connections to all un-surfaced areas and shall be placed and cured in conformance with the recommendations of the monolithic surfacing system manufacturer.
- ii. When cured, the system shall form a continuous, tight-fitting, hard, impermeable surfacing that is approved for potable water system service.
- iii. The system shall effectively seal the interior surfaces of the pipe and prevent any penetration or leakage of groundwater infiltration.
- iv. Heated, plural component, specially designed equipment for use in the application of the specified system approved for use by the monolithic surfacing system manufacturer.
- v. Application procedures shall conform to the recommendations of the interior surfacing system manufacturer, including material handling, mixing, and environmental controls during application, safety, and equipment.
- vi. The equipment shall be specially designated to accurately ratio and apply the specified materials and shall be regularly maintained and in proper working order.
- vii. The specified materials must be applied by an approved installer of the monolithic surfacing system.
- viii. Specially designed spray and/or spin-cast application equipment shall be used to apply each coat of the system.

d. Guarantee of Epoxy Lining

- i. The Contractor shall guarantee all materials and workmanship, furnished under this Contract, against deterioration and failure for a period of 1 year after final acceptance

of all the work under this Contract. Any portion of the epoxy lining found to be deteriorated or to have failed shall be made good by the Contractor in a satisfactory manner by patching or by removal and replacement of the epoxy lining, as required by the Engineer, to provide a sound, durable epoxy lining. Repairs or replacements shall be made in accordance with the requirements specified herein, including removal of defective lining, cleaning the pipe, cutting and repairing or replacing access openings and other incidental work. Repairs or replacements of defective epoxy lining shall be provided by the Contractor at no additional expense to the Owner.

E

TESTING

Reference Section 01600.F for testing requirements

SECTION 01670
Asbestos Cement Pipe

Table of Contents

A..... GENERAL
B..... REFERENCED STANDARDS
C..... SUBMITTALS TO OWNER
D..... ASBESTOS PRE-CONSTRUCTION MEETING
E..... GENERAL CONSTRUCTION REQUIREMENTS
F..... DEFINITIONS

A

GENERAL

Asbestos cement pipe (ACP), also referred to as Transite pipe, is a known health risk to anyone who inhales airborne asbestos particles and fibers. ACP typically contains from 15% to 20% asbestos and is considered asbestos-containing material (ACM). Since ACM is a hazardous material, there are special handling requirements in place by law and by best recommended practices for handling and disposing of asbestos cement products. Conformance with these specifications is intended to minimize the release of asbestos fibers during ACP management and reduce asbestos exposure to acceptable regulatory thresholds.

Important: These handling requirements shall be observed in all instances when working with ACP.

It is the intent of Pennichuck Corporation (Owner), including Pennichuck Water Works (PWW) and Pennichuck Water Service Company (PWSC), that, to the extent possible, existing ACP is to be removed from service and disposed of in accordance with state and federal rules and regulations using means and methods in conformance with all applicable federal and state regulations that limit the release of asbestos fibers to the environment. If the ACP cannot be removed, the ACP shall be abandoned in place with brick-and-mortar closures at all open ends of the pipe or closures by other suitable means. Locations of “abandoned in place” ACP is to be documented in the records for the specific project.

The Contractor shall furnish all materials, equipment, incidental Items, and labor necessary to remove, where feasible, and dispose of all ACP.

Important: All ACP that is disturbed in the course of work shall be removed from the work site in accordance with this specification.

All ACP, ACP fragments, and ACM removed from the site shall be properly handled and their removal properly documented at each step of the disposal process in accordance with applicable federal, state, and local regulations. Copies of all completed ACP disposal documentation shall be submitted to the Owner.

It is anticipated that ACP will be classified as a Category II non-friable ACM, which is not considered regulated asbestos-containing material (RACM). However, the Contractor shall make provisions for the possible discovery or creation of friable ACM, such as degraded or broken ACP, during the work in their fee proposal. Friable ACP is considered RACM.

B

REFERENCED STANDARDS

All work completed under these specifications shall be done in strict accordance with all applicable federal, state, and local regulations, standards, and codes.

1. The most recent edition of any relevant regulation, standard, or code shall be in effect. Where there is a conflict between the regulations, standards, codes, and/or these specifications, the most stringent requirements shall apply.
2. The disturbance and/or removal of ACP is governed by the National Emissions Standards for Hazardous Air Pollutants (NESHAP) 40 Code of Federal Regulations (CFR) 61; by the Occupational Safety and Health Administration (OSHA) 29 CFR 1926.1101; and the New Hampshire Code of Administrative Rules Chapters Env-A 1800, Env-Sw 900, and Env-Sw 2100.
3. ACP is classified by definition under 40 CFR 61, Subpart M, Section 61.141 as Category II, non-friable ACM, unless, when dry, it can be crumbled, pulverized, or reduced to powder by hand pressure. At that time, it becomes classified as regulated ACM (RACM) and subject to regulation under Subpart M.
4. As a minimum, the Contractor shall comply with the applicable portions of the following:
 - a. OSHA, including but not limited to:
 - i. 29 CFR Section 1926 – Safety and Health Regulations for Construction
 - ii. 29 CFR Section 1926.1101 – Safety and Health Regulations for Construction - Asbestos.
 - iii. 29 CFR Section 1910.134 – Occupational Health and Safety Standards - Respiratory Protection.
 - iv. 29 CFR Section 1910.1020 – Occupational Health and Safety Standards - Access to Employee Exposure and Medical Records.
 - v. 29 CFR Section 1910.1200 – Occupational Health and Safety Standards - Hazard Communication.

- b. Environmental Protection Agency (EPA) including but not limited to:
 - i. 40 Code of Federal Regulations Part 61 Subpart M – National Emission Standard for Asbestos.
- c. New Hampshire Code of Administrative Rules, including but not limited to:
 - i. New Hampshire Department of Environmental Services (NHDES) – Asbestos Management and Control, Chapter Env-A 1800.
 - ii. Waste Management Division Solid Waste Rules – Management of Certain Wastes, Chapter Env-Sw 900.
 - iii. Waste Management Division Solid Waste Rules – Management and Control of Asbestos Disposal Sites Not Operated After July 9, 1981, Chapter Env-Sw 2100.

A summary of applicable NHDES rules and regulations follows:

Env-A 1802.27 defines “Facility” as “any institutional, commercial, public, or private building or structure, work place, ship, installation, **utility infrastructure**, active waste disposal site, inactive waste disposal site operated after July 9, 1981, or rental dwelling. [emphasis added]”

Env-A 1802.52 defines “Utility infrastructure” as “any active or abandoned above-ground or underground system intended to convey a service, such as electricity, or to remove a waste, such as sewage, or to store a material, such as fuel, that is either constructed or insulated with ACM, including but not limited to transite pipe, electrical line, water line, sewer line, heating line, roadway, or storage tank.”

ACP that has conveyed water or wastewater is a facility.

Usually, when ACP is installed, it is Category II nonfriable ACM.

However, Category II nonfriable ACM can either become RACM if it:

1. Becomes friable as it deteriorates over time;
2. Has become crumbled, pulverized, or reduced to powder; or
3. Will likely become crumbled, pulverized, or reduced to powder by the forces expected to act on the material in the course of demolition or renovation operations.

In accordance with Env-A 1803.01, an inspection must be conducted by an NHDES-certified asbestos inspector (AI) of the affected portions of a facility for the presence of ACM, prior to undertaking any demolition or renovation of a facility. Because the ACP is typically buried underground and not visible for inspection, it is assumed that ACP is Category II nonfriable ACM for the purpose of project planning. However, at the time when the ACP is exposed for removal, an asbestos inspector is required to determine whether the ACP is or will likely become friable and, therefore, be considered RACM.

If ACP is determined not to be RACM, then the requirements of Env-A 1804.08, Env-A 1805.07, Env-A 1805.08, and Env-Sw 901 would apply. In this case, notification to NHDES is not required.

If the asbestos abatement project involves ACP that is RACM, and the project is not more than 10 linear feet, then the activity would be a minor asbestos abatement project. The term does not include larger projects that are divided into smaller segments. Env-A 1805.13 specifies requirements for minor asbestos abatement projects, which requires, among other things, that the personnel involved in minor projects must be certified, but a licensed asbestos abatement entity is not required. ACM waste produced from a minor asbestos abatement project would also be subject to the requirements of Env-A 1804.08, Env-A 1805.07, Env-A 1805.08, and Env-Sw 901. In accordance with Env-A 1804.02, notification to NHDES is not required for any minor asbestos abatement project.

If the asbestos abatement activity will involve RACM that is more than 10 linear feet, the activity would be a major asbestos abatement project, and a New Hampshire-licensed asbestos abatement contractor must conduct the required asbestos abatement activities after proper notification to NHDES.

Major asbestos abatement projects are subject to the notification requirements of Env-A 1804.01 (an annual notification is also an option under Env-A 1804.04), Env-A 1804.07, and Env-A 1804.09. For an emergency asbestos abatement project, the notification requirements of Env-A 1804.05 would apply. Major asbestos abatement projects are also subject to the work practice requirements of Env-A 1805. Once ACP is removed from the facility, it is asbestos waste and subject to the requirements of Env-Sw 901.

Any alternative procedure to an asbestos abatement requirement can be requested using the procedures described under Env-A 1807.02.

The following ACP Project Decision Tree outlines the NHDES submittal and notification requirements for anticipated ACP projects.

B.1 - ACP Project Decision Tree

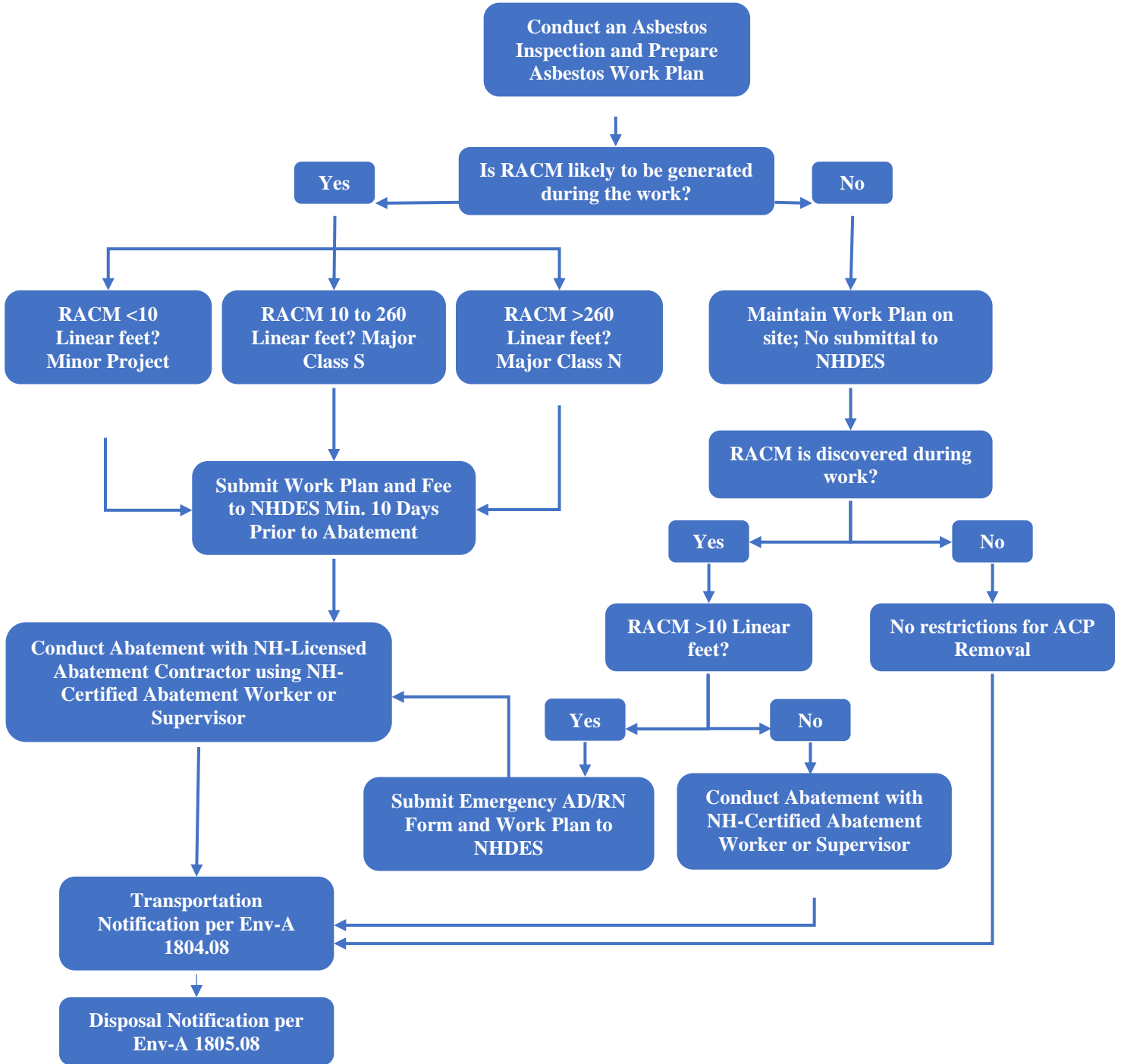

C

SUBMITTALS TO OWNER

1. Asbestos Removal Work Plan

The Contractor shall develop an Asbestos Removal Work Plan (work plan) that provides specific and detailed procedures (means and methods) that will be followed during ACP removal. The work plan must be submitted to the Owner and, if applicable, NHDES for review and approval 15 days prior to beginning work. The Contractor shall submit the work plan to the Owner prior to submittal of any plans to NHDES. Work plans submitted with insufficient detail will be returned requesting more information be provided. The Contractor shall comply with NHDES and any other agencies requirements during work plan preparation.

The Asbestos Removal Work Plan shall include:

- a. Proposed means and methods that are protective of human health and the environment and conform to all applicable state and federal rules and regulations unless a waiver has been obtained.
- b. Procedures/actions to be followed if the intact ACP becomes broken and the possibility exists of asbestos fibers becoming airborne.
- c. A list of equipment that will be used during the abatement and/or associated site work disturbing ACM.
- d. Copies of the abatement contractors' licenses and certifications and a list of qualified personnel that will be on site and their contact information.
- e. Copies of all associated permits, notifications, or waivers (including any correspondence or approvals) necessary to complete the work.
- f. The proposed locations within the project where ACM is located, where ACM is anticipated to be impacted and proposed locations for temporary on-site storage or stockpiles.
- g. Description of equipment and personnel decontamination procedures.
- h. Description of access controls and site security plans (stockpile and storage locations shall be included).

- i. Description of best management practices (BMPs) and/or engineering controls, as well as physical and visual controls to be deployed in or around the regulated areas and temporary storage/stockpile locations.
- j. The work plan submitted shall contain the following:
 - i. The scope of work to be accomplished regarding ACP shall be described in detail. For example: abandoning/removing X feet of ACP; tying into one or more joint(s)/section(s) of an existing water main and replacing one or more joints/sections (X feet) of pipe to make the connection; removing X feet of buried ACP encased in concrete crossing a drainage way not accessible by road; or connecting to an existing joint/section of ACP by tapping into the ACP.
 - ii. Detailed procedures that describe the methods/techniques to be employed to uncover, dislodge, handle, remove, secure, transport, and dispose of the ACP and any generated ACM waste.
- k. The work plan shall state or reference procedures in the contractor's health and safety program document that they will follow to comply with the federal OSHA asbestos standard.
- l. The work plan shall contain provisions for the environmentally compliant disposal of the intact ACP and any RACM created during the removal process.
- m. The work plan shall provide detailed procedures for retaining the ACP's Category II, non-friable NESHAP classification.
- n. The Contractor shall incorporate working with ACM and complying with mandated OSHA requirements for Class II, asbestos work in their project specific health and safety plan.
- o. Steps to inspect and maintain stockpiles until ACM is properly disposed.
- p. Proposed means and methods of ACM disposal and proposed licensed ACM disposal facility.

2. Disposal Documentation

- a. Submit proof satisfactory to the Owner, and as applicable, NHDES, that required permits, site location, and arrangements for transport and disposal of asbestos-containing waste material (ACWM) have been made that meet applicable environmental statutes and regulations.

- b. Include the name of the transporter and the name of the approved landfill where the ACP and ACWM will be buried.
- c. Submit copies to the Owner and if applicable, NHDES, of all transport manifests, trip tickets, and disposal receipts for all ACWM removed from the work area during the project.
- d. The Contractor will sign manifests as the Owner's representative (generator) for the ACP and provide copies to the Owner.

3. Notifications

The Contractor shall provide written notification to NHDES Air Resources Division (ARD) and the local municipality, as applicable, for major asbestos abatement projects that anticipate generating more than 10 linear feet of RACM at least ten (10) working days prior to starting ACP removal in accordance with Env-A 1804.01 Notification for Major Asbestos Abatement Projects.

If the start and/or completion date changes or a break in operation occurs, the Contractor shall notify NHDES ARD within 24 hours of changing the date(s) or interrupting the operation via telephone, fax, or email as specified in Env-A 1801.04(b); and provide a paper copy of the revised notification to NHDES within one business day.

The Contractor providing notice to NHDES shall also provide the requisite notification fee, as provided in Env-A 1804.09 Notification Fees.

(see <https://www.des.nh.gov/sites/g/files/ehbemt341/files/documents/2020-01/Env-A%201800.pdf>)

Notification to NHDES is not required for projects where RACM is not anticipated to be generated during the ACP removal or for minor asbestos abatement projects that anticipate generating less than 10 linear feet of RACM. However, if greater than 10 linear feet of RACM is subsequently generated, notification to NHDES will be required as a major project.

All transporters of asbestos waste must provide NHDES with transport and disposal notification in accordance with Env-A 1804.08 and Env-A 1805.08. In all instances where greater than 10 linear feet, 25 square feet or 3 cubic feet of asbestos waste is disposed of, a waste shipment record must be sent to NHDES within 30 days of the delivery of the asbestos waste to the permitted disposal facility.

D

ASBESTOS PRE-CONSTRUCTION MEETING

The Contractor shall meet with the Owner at the project site, a minimum of 2 weeks prior to beginning abatement work. The Contractor shall be represented by an authorized representative and the field supervisor who shall supervise the project on a daily basis. The Contractor shall present evidence that all requirements for initiation of the work have been met. The minimum agenda for the meeting shall be:

1. Review of Pre-Job Submittals.
2. Channels of communication.
3. Construction schedule, including sequence of critical work.
4. Designation of responsible personnel.
5. Procedures for safety, security, quality control, housekeeping, and related matter.
6. Use of premises, facilities, and utilities.

The Contractor is required to provide one copy of the following at the preconstruction meeting:

1. Asbestos Abatement Contractor's Entity License.
2. State and Local Notifications, as required.
3. A list of abatement employees to be used on the project. Copy of licenses, training certificates and fit-tests of all workers and supervisors who will work on the project.
4. Documentation of medical records as required by OSHA or a notarized statement by examining medical doctor that such examinations took place and when, for each employee to be used on the project (preferred).
5. Copy of state or local license numbers for waste hauler and waste disposal site.

E

GENERAL CONSTRUCTION REQUIREMENTS

The ACP is considered by the U.S. EPA as Category II, non-friable ACM. The Owner wants its pipe to retain that asbestos categorization. By using procedures that have a low to no probability of fiber release, the pipe retains its classification as Category II, non-friable ACM.

1. No handling and disposing of ACP will begin without approval from the Owner.
2. The Contractor shall uncover, dislodge, handle, remove, transport, and dispose of all ACP specified in the contract documents for this project using wet technique procedures.
3. All work involving ACP and other ACM must be addressed in the work plan.
4. The Contractor shall take precautions to prevent damage to adjacent structures and material/finished material not required for ACP handling.
5. All projects involving ACP require that NESHAP and OSHA standards are met and/or exceeded.
6. To comply with NESHAP and OSHA requirements, this project will require workers trained in using wet technique procedures to dislodge and remove ACP, ACP joints, valves (any type) containing ACM, and any surrounding soils that may contain ACM.
7. OSHA requires that during any ACM disturbance, regardless of amount, the asbestos worker(s) shall be protected from potential airborne asbestos exposure in excess of the permissible exposure limit or excursion limit as stipulated in 29 CFR 1926.1101.
8. Contractors shall not use procedures that subject the ACP to forces that will crumble, pulverize, or reduce to powder the ACP.
 - a. Once the pipe becomes crumbled, pulverized, or reduced to powder it becomes classified as RACM and subject to NESHAP.
9. The following work practices and engineering controls shall not be used for work related to ACP or for work which disturbs ACM, regardless of asbestos exposure or the results of Initial Exposure Assessments:
 - a. High-speed abrasive disc saws and sanders that are not equipped with point-of-cut ventilator or enclosures with HEPA filtered exhaust air or wet cutting equipment;
 - b. Carbide-tipped cutting blades;
 - c. Electrical drills, chisels, and rasps used to make field connections in ACP;
 - d. Shell cutters used to cut entry holes in ACP;

- e. A hammer and chisel without using wet techniques to remove pipe connections;
 - f. Compressed air used to remove asbestos or material containing asbestos;
 - g. Dry sweeping, dry shoveling, or other dry clean-up of dust and ACM debris;
 - h. Employee rotation as a means of reducing employee exposure to asbestos.
10. Saw cutting of ACP shall only be conducted with a HEPA-shrouded vacuum attachment or wet cutting equipment, unless it is conducted within a small enclosure that isolates the area in which the saw cutting is being conducted to prevent the release of asbestos fibers to ambient air. These procedures will protect workers from the health risk associated with airborne asbestos.
 11. To meet and/or exceed NESHAP and OSHA guidelines, the contractor may subcontract the ACP handling and removal work to an EPA-accredited and New Hampshire-certified asbestos abatement contractor, asbestos abatement worker, or a certified asbestos abatement company.
 12. ACP uncovering, dislodging, handling, and/or removing shall be conducted during regular business hours, 8 a.m. to 5 p.m., Monday-Friday, where possible.
 13. Disposal bags for RACM shall be 6-mil polyethylene and labeled as required by EPA Regulation 40 CFR 61.150 (a)(1)(iv) or OSHA requirement 29 CFR 1926.1101(k)(8).
 14. Stick-on labels identifying the generator's name (Pennichuck Corporation) and address and the project site location shall be applied to any asbestos waste disposal bag that contains RACM, as per EPA or OSHA and Department of Transportation requirements.
 15. The Contractor shall remove and double bag with 6-mil polyethylene sheeting to yield a total of at least 12-mil, the asbestos pipe in the trench or immediately when it comes out of the trench, seal, label, transport, and dispose of all Category II non- friable ACM and RACM in compliance with applicable current federal, state and local regulations, laws, ordinances, rules, standards and regulatory agency recommended requirements.
 16. Time is of the essence in removing the ACM from the project area.
 17. All notifications required to state regulatory agencies and local municipality will be made by the Contractor with copies provided to the Owner.
 18. The Contractor shall have an on-site supervisor, who is an OSHA Competent Person, present on the job site at all times that the ACP work is in progress.
 - a. Supervisor shall be thoroughly familiar with and experienced at asbestos pipe handling using wet techniques and shall be familiar with and shall enforce the use of all safety procedures and equipment.

PENNICHUCK WATER WORKS

- b. Supervisor shall be knowledgeable of all applicable EPA, OSHA, and NHDES asbestos requirements and guidelines.
19. The Contractor has sole and primary responsibility for the “means and/or methods” of the work; an obligation to the Owner to inspect all stages of the work; and sole responsibility to supervise the performance of the work.
 20. Certain work practices for ACP disturbance are prohibited as per this Specification.
 21. The Contractor shall be responsible for site safety and for taking all necessary precautions to protect the Contractor’s and Owner’s personnel and the public from airborne asbestos exposure and/or injury.
 22. The Contractor shall be responsible for maintaining the integrity of the work area.
 23. The Contractor shall confine operations at the site to the area requiring interface with the ACP and the general site area in close proximity to the project.
 24. The Contractor will not unreasonably encumber the site with materials or equipment.
 25. If ACWMs are required to be stored overnight in a secured area, the waste material and waste containers shall be labeled according to OSHA, EPA, and New Hampshire requirements, and containerized to preclude unauthorized disturbance of the ACWMs.
 26. The Contractor shall be responsible for obtaining and coordinating waste disposal and transport of ACWM to a permitted asbestos waste landfill.
 27. The Contractor shall demarcate the area of ACP interface (“regulated area”) with barrier tape and warning signs, per OSHA regulation 29 CFR 1926.1101.
 - a. Access to the regulated area will be limited to authorized personnel and visitors.
 - b. The contractor shall identify in their site-specific health and safety plan how they intend to limit access and who is authorized to be in the demarcated area.
 28. Abandonment of ACP:
 - a. The Contractor is responsible for isolating the existing mains to remain in place by capping, plugging and blocking as necessary.
 - b. The opening of an abandoned ACP and all other openings or holes shall be blocked off by manually forcing cement grout or concrete into & around the openings in sufficient quantity to provide a permanent watertight seal.
 29. The Contractor’s on-site Competent Person shall inspect the work area, verify, and certify that no residual ACP fragments and debris remain.
 30. The Contractor shall allow for field survey of left-in-place ACP by the Owner prior to completion of the work.

F

DEFINITIONS

ACM	Asbestos-containing material
ACWM	Asbestos-containing waste material
ACP	Asbestos cement pipe
AI	NHDES-certified asbestos inspector
BMPs	Best management practices
CFR	Code of Federal Regulations
EPA	U.S. Environmental Protection Agency
GPS	Global Positioning System
NESHAP	National Emissions Standards for Hazardous Air Pollutants
NHDES	New Hampshire Department of Environmental Services
OSHA	Occupational Safety and Health
Owner	Pennichuck Corporation (Owner), including Pennichuck Water Works (PWW) and Pennichuck Water Service Company (PWSC)
PPE	Personal Protective Equipment
RACM	Regulated Asbestos-Containing Material; friable ACM

Friable - Friable means that the material can be crumbled with hand pressure and is therefore likely to emit fibers. ACP can emit airborne fibers if the materials are cut or sawed, or if they are broken. Friable ACM is considered regulated ACM (RACM).

Category II non-friable ACM - ACP is classified by definition as non-friable, but can become friable as it deteriorates over time or has become or is likely to become crumbled, pulverized, or reduced to powder during the course of the ACP removal.

Competent Person - Competent person means, in addition to the definition in 29 CFR 1926.32 (f), one who is capable of identifying existing asbestos hazards in the workplace and selecting the appropriate control strategy for asbestos exposure, who has the authority to take prompt corrective measures to eliminate them, as specified in 29 CFR 1926.32(f): in addition, for Class I and Class II work who is specially trained in a training course which meets the criteria of EPA's Model Accreditation Plan (40 CFR part 763) for supervisor, or its equivalent and, for Class III and Class IV work, who is trained in a manner consistent with EPA requirements for training of local education agency maintenance and custodial staff as set forth at 40 CFR 763.92 (a)(2).

SECTION 01680
Temporary Water Mains and Services

Table of Contents

A..... GENERAL
B..... RELATED PRODUCTS
C..... PRODUCTS
D..... EXECUTION
E..... TESTING

A

GENERAL

The Contractor shall furnish all materials, equipment, incidental Items, and labor necessary to install, maintain, and remove temporary water mains and services as indicated on the Drawings and as detailed in the Specifications.

The Contractor shall hook up temporary water services to every building along the temporary water main route using a minimum pipe size of $\frac{3}{4}$ inch inside diameter unless otherwise specified on the Drawings. Temporary water service shall be provided through exterior sill cocks or through the existing water service pipe in accordance with the Drawings.

B

RELATED WORK

Section 01400 Earth Excavation, Backfill, Fill, and Grading

Section 01670 Cleaning and Lining of Cast Iron Water Mains

C

PRODUCTS

1. Temporary Water Mains

- a. All temporary water main pipes shall be of the size specified by the Engineer.
- b. All temporary water main fittings and connections shall be rated for a minimum working pressure of 200 psi.
- c. Temporary water mains not specified by the Engineer shall be designed by the Contractor and approved by the Engineer.

2. Temporary Water Service

All temporary water service pipes shall be 1-inch diameter CTS high-density Polyethylene or its approved equivalent, unless otherwise approved by the Engineer. All temporary water service pipes shall have a minimum inside diameter of ¾ inch.

D

EXECUTION

1. Phasing the Work

- a. All temporary water mains shall be installed as approved by the Engineer. The installation of all temporary water mains shall be phased based on the availability of feed water for the temporary water main. All temporary water mains must be installed, chlorinated, and tested for bacterial contamination testing prior to connecting any temporary water services.
 - i. When the Contractor has completed construction of the new water main system, they shall remove all temporary water mains and service and restore all damaged roads, sidewalks, drives, curbs, lawns, and other areas that have been disturbed by the Contractor's construction operations to their original condition.

2. Constructing Temporary Water Mains

- a. If the Contractor decides to install a temporary water main in a location or fashion different from that approved by the Engineer, the Contractor shall prepare Drawings showing the alternate layout together with details of the connections to the point of supply, materials to be used (type and size), details of crossing the traveled way, precautionary measures for the protection of the temporary bypass lines, public health and safety
- b. The Contractor shall ensure that all dead ends on temporary water mains are provided with a valve and a blow-off that can be used when filling or flushing the temporary water main.
- c. The Contractor shall install a pressure-reducing valve on any temporary water main where the anticipated pressure may exceed 80 psi at its low point. The pressure-reducing valve shall be the same size as the temporary water main.

- d. The Contractor shall submit to the Owner an emergency response plan for dealing with any problems that may occur with the temporary water main system while in service. The emergency response plan shall be cover the work site 24 hours per day and seven days per week with a maximum response time of 30 minutes. The emergency response plan shall be approved and in place before beginning work on installing the temporary water main system.
- e. The Contractor shall ensure that all temporary water mains are buried at each street crossing. Temporary water mains shall be ramped at each driveway crossing and each sidewalk crossing per *Standard Detail T04*. The Contractor shall deploy watchmen, lights barriers, signs, and such other methods as may be necessary or required to prevent injury to persons and property and to comply with all Federal, State and municipal safety codes, ordinances, and regulations.
- f. The Contractor shall ensure that all temporary water mains are located outside of the traveled way except where impractical. The temporary water main shall be placed in a location where it will cause the least obstruction and inconvenience and where it will be subject to the least amount of possible damage.
- g. Fire Department connections shall be provided in locations specified by the Engineer and as shown on *Standard Detail T03*.

3. Constructing Temporary Water Service Lines

- a. The Contractor shall ensure that temporary water service lines are hooked up to every building along the temporary water main route. Temporary water service shall be provided through exterior sill cocks or through the existing service.
- b. The Contractor shall ensure that all sill cock connections are made using a “Siamese” connection with two shut-off valves. The first shut-off valve shall be used to control the temporary water service flow and second shut-off valve shall have a standard hose bib thread to allow for the continued use of the sill cock for any outside watering requirements.
- c. The Contractor shall ensure that all sill cock connections are made with sufficient slack left in the temporary water service line to allow for movement of at least 3 feet in either direction from its original location to facilitate any lawn and yard maintenance.
- d. The Contractor shall ensure that each temporary water service line is connected to the temporary water main with a ball-style corporation shut-off valve.

- e. When the Contractor has completed construction of the new water main system, they shall remove all temporary water mains and service lines and restore all damaged roads, sidewalks, drives, curbs, lawns, and other areas that have been disturbed by the Contractor's construction operations to their original condition.

E

TESTING

1. Conducting Pressure Tests

- a. The Owner's Representative shall conduct a thorough visual inspection of all newly-placed temporary water services after the Contractor has completed their installation work and before any backfill operations begin.

2. Conducting Flushing and Disinfection Operations

The Contractor shall conduct flushing and disinfection operations using methods and procedures that meet the requirements of *AWWA C601*. All costs associated with flushing and disinfecting the temporary water main shall be borne by the Contractor.

Samples from the disinfected water main shall be submitted to an EPA approved laboratory for bacteriological analysis. If the sample fails bacteriological testing, the Contractor shall then perform additional flushing and disinfection operations until subsequent test samples indicate safe bacteria levels.

Any additional flushing and disinfection operations shall be conducted at the Contractor's expense.

The Contractor shall install suitable taps at the end of the disinfected water main to enable the collection of samples for bacteriological testing.

[This page has been left intentionally blank]

SECTION 01800

Crushed Gravel

Table of Contents

A..... GENERAL
B..... RELATED WORK
C..... PRODUCT
D EXECUTION

A

GENERAL

The Contractor shall furnish, place, and compact crushed gravel in authorized excavations as ordered by the Owner's Representative and as indicated on the Plans.

B

RELATED WORK

Section 02300 Paving

C

PRODUCT

The Contractor shall use crushed gravel that has been screened and well-graded in sizes from $\frac{3}{8}$ inch to $\frac{3}{4}$ inch, or other such sizes as may be approved by the Engineer. Approved gravel shall consist of clean, hard, and durable particles or fragments. Approved gravel shall be free of dirt, vegetable matter, or any other objectionable materials, and shall not have an excess of soft, thin, elongated, laminated, or disintegrated pieces.

Gravel shall meet or exceed the requirements of the New Hampshire DOT General Specifications for Item No. 304.3, *Crushed Gravel* or Item No. 304.4, *Crushed Stone (Fine)*. The Contractor may substitute the use of screened crushed gravel with suitably sized and graded crushed stone with the Engineer's approval. The Specifications in this section shall apply to both aggregate types.

D

EXECUTION

- a. The Contractor shall ensure that the crushed gravel is spread in layers of uniform thickness not greater than 12 inches, and then thoroughly compacted by means of a suitable vibrator or mechanical tamper. The Contractor shall ensure that the crushed gravel is compacted to at least 95% maximum dry density and meets the requirements of *ASTM D1557, Standard Test Methods for Laboratory Compaction Characteristics of Soil Using Modified Effort (56,000 ft-lbf/ft³ (2,700 kN-m/m³))*.
 - i. The Contractor shall ensure that all subgrade lifts are rolled with a vibratory roller capable of producing a dynamic force of 27,000 lbs, making four passes over the subgrade prior to placing the crushed gravel.
 - ii. The Owner shall assume the responsibility for employing a competent and licensed Soils Engineering firm to conduct testing and analysis as may be required. The Contractor shall provide access for Soils Engineer to the crushed gravel to be used on this job a minimum of two weeks prior to the placement of any structural fill so that the maximum soil density may be properly determined.

[This page has been left intentionally blank]

SECTION 01900

Gravel Aggregate for Road Base and Water Main Backfill

Table of Contents

A..... GENERAL
B..... RELATED WORK
C..... PRODUCT
D..... EXECUTION

A

GENERAL

The Contractor shall furnish, place, and compact bank run gravel as indicated on the Drawings or as ordered by the Engineer

B

RELATED WORK

Section 01400 Earth Excavation, Backfill, Fill, and Grading

Section 01600 Water Main Pipe and Fittings

Section 01800 Crushed Gravel

C

PRODUCT

The Contractor shall use bank run gravel that is granular material, well-graded in sizes from fine to coarse, with a maximum size of 6 inches. Bank run gravel shall meet or exceed the requirements of the New Hampshire DOT General Specifications for Item No. 304.2, Gravel. The Contractor shall ensure that bank run gravel is obtained from approved natural deposits and unprocessed except for the removal of unacceptable materials and stones larger than the maximum size permitted.

D

EXECUTION

Bank run gravel shall be spread in layers of uniform thickness not exceeding 12 inches before compaction and moistened or allowed to dry as directed. Then it shall be thoroughly compacted by means of suitable power driven tampers or other power driven equipment to at least 95% maximum dry density to meet the requirements of *ASTM D1557*.

SECTION 02000

Common Borrow

Table of Contents

A..... GENERAL
B..... RELATED WORK
C..... PRODUCT
D EXECUTION

A

GENERAL

The Contractor shall furnish, place, and compact selected borrow as indicated or directed. In most cases, common borrow will be generally classified as material (other than rock) excavated from the trench unless deemed unsatisfactory by the Engineer due to the presence of substantial amounts of clay, vegetable matter, or other deleterious material.

If additional common borrow is required beyond that available from normal excavation activities, then such common borrow shall meet the minimum requirements specified in this Section.

B

RELATED WORK

Section 01400 Earth Excavation, Backfill, Fill, and Grading

C

PRODUCT

The Contractor shall use common borrow that meets the following requirements:

- Common borrow shall be inorganic natural soils and/or rock having not more than 5% by weight passing the No. 200 sieve.
- Common borrow shall have a maximum stone size of 6 inches and material well-graded throughout entire site range.
- Common borrow shall be free from roots, leaves, and other organic materials.
- Common borrow shall be free from ice or frost with no frozen soil particles
- Common borrow shall have a moisture content that is $\pm 4\%$ of the optimum moisture content at the borrow source.

D

EXECUTION

The Contractor shall spread selected borrow in layers of uniform thickness not exceeding 12 inches before compaction and moistened or allowed to dry as directed. The Contractor shall compact common borrow thoroughly by means of suitable power-driven tampers or other power-driven equipment. Refer to *Standard Detail M02* for more information.

[This page has been left intentionally blank]

SECTION 02100

Sand

Table of Contents

A..... GENERAL
B..... RELATED WORK
C..... PRODUCT
D EXECUTION

A

GENERAL

The Contractor shall furnish and place sand as indicated on the Drawings, as directed by the Engineer, or as herein specified.

B

RELATED WORK

Section 01400 Excavation, Backfill, Fill and Grading

Section 01650 Water Service Materials

Section 02450 Styrofoam Insulation

C

PRODUCT

Aggregate for sand shall be sand of hard, durable particles free from vegetable matter, lumps or balls of clay, and other deleterious substances. The gradation shall meet the grading requirements of the following table:

Table 02100A – Sand Aggregate Gradation

Sieve Designation	% by Weight Passing Square Mesh Sieve
3/8 in	85 – 100
No. 200	0 -10

D

EXECUTION

The Contractor shall spread sand in layers of uniform thickness not exceeding 12 inches before compaction and moistened or left in natural state as directed. The Contractor shall thoroughly compact the sand by means of suitable power-driven tampers or other power-driven compaction equipment.

[This page has been left intentionally blank]

SECTION 02200

Loam and Seed

Table of Contents

A..... GENERAL
B..... SUBMITTALS AND TESTING
C..... PRODUCT
D..... EXECUTION
E..... MAINTENANCE AND ACCEPTANCE

A

GENERAL

The Contractor shall furnish all labor, materials, tools, and equipment necessary to do all loaming and seeding and temporary seeding where indicated on the Drawings and as herein specified.

B

SUBMITTALS AND TESTING

1. Loam

- a. The Contractor shall provide two representative 5-gallon topsoil samples to the Owner's Representative 15 days prior to its use on-site. Samples shall indicate the location of the source material. If additional sources shall be used during the project, the Contractor shall provide samples for all locations. At the Owner's Representative's request, the Contractor shall have the topsoil sample tested for physical properties and pH (or lime requirement), organic matter, available phosphoric acid, and available potash, in accordance with standard practices of soils testing for agricultural uses.
- b. All topsoil shall be screened clear of all stones greater than ½ inch, as well as sticks, plants and all other foreign materials before being spread. 100% of the material shall pass the ½ inch sieve and at least 90% shall pass the No. 10 sieve.
- c. All topsoil shall have a pH range between 6 – 7.

C

PRODUCT

1. Loam

- a. Loam shall be a good grade of topsoil from a site approved by the Owner's Representative. The loam shall be loose and friable and shall be free from admixtures of subsoil, refuse, large stones, clods or roots, or any other undesirable foreign matter. Muck, peat, or other excessively acidic soils containing undue proportions of either clay or sand will not be accepted.

PENNICHUCK WATER WORKS

The Owner’s Representative will have final determination as to whether the topsoil is representative of the submitted topsoil samples. If any materials are found to be inadequate, the Owner’s Representative will reject them and the rejected topsoil will be removed from the site at the Contractor’s expense.

- b. When designated on the Plans or as directed, existing topsoil found within the lines of improvement in excavation areas, embankment areas, or both, shall be excavated and stockpiled by the Contractor for later use as loam on slopes and other areas, or on future work. Stockpiles shall be placed at designated locations.

Additional loam to complete the project, if required, shall be obtained by the Contractor from sources beyond the site. Unless designated for future work, salvaged topsoil not required for use on slopes shall be graded to match the surrounding terrain and the area seeded and mulched.

2. Permanent Seed

- a. Seed shall be certified as to its proper mixture, germination, and purity qualities. Each variety of seed shall have germination rate of at least 80%, a purity of at least 85%, and a weed content of no more than 1%. All seed shall be from the same or previous year's crop unless recent tests by an approved testing agency demonstrate that older seed meets the above requirements.
- b. The seed mixture shall consist of seed proportioned percent by weight as follows:

Table 2200A – Seed Mixture Proportions

Method Number 1 – Park Mixture	
Creeping Red Fescue	50%
Kentucky Bluegrass	30%
Annual Ryegrass	20%

3. Temporary Seed

Temporary seed shall be Winter Rye.

4. Mulch

- a. Hay or straw mulch shall consist of long-fibered hay or straw, reasonably free from noxious weeds and other undesirable material. No material shall be used which is so wet, decayed, or compacted as to inhibit even and uniform spreading. No chopped hay, grass clippings, or any other short-fibered material shall be used unless directed.

- b. Cellulose fiber mulch shall consist of elongated virgin wood fibers capable of producing a strong yellow-brown reaction with Graff C Stain for the presence of lignin in accordance with *TAPPI Test T 401 OS-74*. The ash content shall not exceed 2.0%.
- c. The material shall be non-toxic to plants and animals upon contact and shall contain a green color sufficient to provide a definite contrast with the ground surface for metering purposes. It shall be supplied in uniform moisture resistant package not exceeding 100 pounds each and marked to show the air-dried weight for tank mixing purposes.

D

EXECUTION

1. Loam

Loam shall be spread uniformly on prepared areas to the depth of 4 inches as shown on the Plans or as directed. Any remaining clods, roots, stones measuring over ½ inch, and all other foreign matter, shall be removed. All loam shall be brought to a true, even surface, meeting the required grade.

2. Seeding Method for Permanent Seed

- a. Preparing the Soil. After the loamed or un-loamed areas to be seeded have been brought to grade, all ground not loose and friable shall be scarified to a depth of at least 2 inches immediately before seeding or mulching. All stones measuring over ½ inch and all objects which would be detrimental to mowing shall be removed and disposed of as directed. Hand raking will not be required provided an acceptable surface can be obtained by other means.
 - i. Fertilizing and Applying Agricultural Ground Limestone. Fertilizer and agricultural ground limestone shall be applied at a rate of 30 pounds of 10-10-10 fertilizer per 1,000 square feet of loamed area. Ground limestone shall be applied at a rate of 25 pounds per 1,000 square feet of loamed area.
 - ii. Sowing Seed. The seed shall be sown as specified in the NHDOT Standard Specifications for Road and Bridge Construction unless otherwise indicated on the Plans or as approved. The seed shall be Park Mixture as specified above and shall be applied at a minimum rate of 3 pounds per 1,000square feet of loamed area.
 - iii. Mulching. Mulch shall be applied as specified in the NHDOT Standard Specifications for Road and Bridge Construction unless otherwise indicated on the Plans or as directed.

Mulch should be applied at a rate of 1 to 2 tons per acre in a uniform blanket. Clumped or thick mulch shall be thinned.

3. Seeding Method for Temporary Seed

- a. Sowing Seed. The seed shall be sown as specified in the NHDOT Standard Specifications for Road and Bridge Construction unless otherwise indicated on the Plans or as directed.
 - i. Mulching. Mulch shall be applied as specified in the NHDOT Standard Specifications for Road and Bridge Construction unless otherwise indicated on the Plans or as directed.

4. Hydroseeding

Hydroseeding with a cellulose fiber mulch applied as a waterborne slurry at a rate of 60 pounds of mulch per 1,000 square feet of area, when mixed with proper quantities and types of seed, fertilizer, and agricultural limestone, may be used in lieu of separate mulching and seeding.

E

MAINTENANCE AND ACCEPTANCE

1. Seeding, Watering, and Repairs

Seeding shall be done by either method between the dates of March 31st to September 30th, inclusive. The Contractor shall maintain each seeded area until acceptance of the individual area.

Important: Maintenance shall include watering the newly-seeded area until permanent grass growth is established over 85% of the disturbed area.

The Contractor is responsible for all cost of watering; including the cost of the water. Maintenance shall also consist of providing protection by erecting necessary signs or barriers and by repairing damaged areas as directed. Damaged areas shall be repaired by reestablishing the grade of the area prior to damage and by reapplying mulch. Refertilizing and reseeded will not be required during this period.

Necessary maintenance or repairs will not be paid for but shall be considered incidental to the Contract. Areas fertilized, seeded, and mulched by either method between October 1st and March 31st will be accepted only upon attainment of a reasonably thick uniform stand of grass free from sizable thin or bare spots.

2. Maintaining Seeded Areas

When all other work on the project has been completed and some seeded areas still have not been accepted, the Contractor shall maintain those areas for an additional 60 days, exclusive of the periods from November 15th to April 15th. The seeded areas will be accepted upon attainment of a reasonably thick uniform stand of grass.

If unaccepted areas still remain at or near the end of the 60-day maintenance period, the Owner's Representative may direct a final reseeded by the Contractor or may deduct the Contract value of the unaccepted area from payment due the Contractor. In either event, the Contractor's responsibility for the seeded areas will terminate at the end of 60 days and the seeded areas will be accepted as complete.

3. Acceptance

The acceptance of any seeded area shall be in writing. After acceptance, the Contractor will be relieved of further expense for maintaining the areas, except for damage resulting from their own or their Subcontractor's operations.

SECTION 02250

Chain Link Fence

Table of Contents

A..... GENERAL
B..... RELATED WORK
C..... PRODUCTS
D..... EXECUTION

A

GENERAL

The Contractor shall furnish and install chain link fencing, gates, barbed wire, and other associated materials as indicated on the drawings and as detailed within the specifications below.

B

RELATED WORK

Section 01400.....Earth Excavations, Backfill, Fill, & Grading

C

PRODUCTS

1. Chain Link Fence

- a. All fence posts, tension wire, barbed wire and mesh shall be hot dipped galvanized. The fence post, top rail, tension wire and mesh shall also be poly-vinyl coated.
- b. Fence Posts -
 - i. Line Posts - Shall be 2-1/2" in diameter, Schedule 40 and shall be hot dipped galvanized.
 - ii. Terminal/Corner Post - Shall be 3" in diameter, Schedule 40 and shall be hot dipped galvanized terminal posts shall be set at all changes in fence direction exceeding 45 degrees.
 - iii. Gate Posts - Shall be 4" diameter, Schedule 40 and shall be hot dipped galvanized.
- c. Fence mesh shall be 2" square and shall be hot dipped galvanized after weaving. The wire gauge of the mesh will be No 9. Where specified on the plans the wire mesh shall be coated with a minimum of 7 mils of poly-vinyl chloride permanently bonded to the galvanized wire via thermal fusion bonding.

- d. The fence shall be provided with a 1-5/8" top rail. The top rail shall be hot dip galvanized. The fence shall be equipped with a bottom galvanized tension wire. The bottom tension wire shall be a minimum of 7 gauge and shall be attached to the fence mesh at maximum intervals of 24" with 11 gauge hog rings. Where the fencing is vinyl coated the bottom tension wire and hog rings shall also be vinyl coated. The top of the fence shall be provided with three strands of barbed wire, pointing out from the top of the fence at a 45 degree angle.
- e. Provide the fence mesh with an intermediate horizontal brace in order to produce fence stability at all terminal and gate posts. Where brace rods are used they shall be equipped with a 3/8" diameter truss rod and turnbuckle. The truss rod and turnbuckle shall be hot dipped galvanized.
- f. The top of the fence and gates shall be protected with three strands of barbed wire supported on arms that are supported on the posts and shall be at approximately 45 degrees to the vertical. The barbed wire and supports shall be capable of supporting a minimum of 250# load applied to the outer barbed wire strand without breaking. The barbed wire shall be hot dipped galvanized and shall conform to ASTM A-121, chain link fence grade.
- g. Gate - The gate latch, hinges, and bracing shall be hot dip galvanized. The gate shall have a center pin that latches the gate leafs into the ground. Provide a 1" diameter by 18" long galvanized receiver pipe in the ground below the center of the gates to receive the center pin.

D

EXECUTION

1. All fence posts shall be set true and vertical.
2. Line posts shall be set a minimum of 32" deep in a concrete footing. The concrete shall be a minimum of 2,000 psi concrete @ 28 days.
3. Terminal posts shall be set a minimum of 36" deep in a concrete footing.
4. Gate posts shall be set a minimum of 42" deep in a concrete footing.
5. All concrete footings shall extend at least 4" below of the post set in them. Minimum concrete footing diameter for line and terminal posts is 12". The minimum concrete footing diameter for gate posts is 15".
6. Posts spacing shall not exceed 10' on center.
7. The bottom of the fence mesh shall be within 2" of the ground.

[This page has been left intentionally blank]

SECTION 02300

Paving

Table of Contents

A..... GENERAL
B..... RELATED WORK
C..... QUALITY ASSURANCE
D..... SUBMITTALS
E..... PRODUCT
F..... EXECUTION

A

GENERAL

The Contractor shall provide all labor, tools, equipment and materials required to pave the all areas to the thickness and types as defined on the Plans. All paving construction methodologies shall meet or exceed those defined in *Section 401, Plant Mix Pavements – General* of the current NHDOT Standard Specifications for Road and Bridge Construction.

B

RELATED WORK

Section 01400 Earth Excavation, Backfill, Fill, and Grading

Section 01800 Crushed Gravel

Section 01900 Gravel Aggregate for Road Base and Water Main Backfill

Section 02600 Clean Up

C

QUALITY ASSURANCE

The Contractor shall ensure that their paving operations conform to the requirements of *Section 304 – Aggregate Base Course* and *Section 403 – Hot Bituminous Paving* of the current NHDOT Standard Specifications for Road and Bridge Construction.

The Engineer reserves the right to inspect all paving materials and the preparation of paving materials at the paving plant.

The Contractor shall ensure that paving operations are conducted in accordance with all State and local requirements.

D

SUBMITTALS

The Contractor shall submit a paving mix design with laboratory tests certifying conformance with Specifications for the bituminous paving materials to the Engineer.

The Contractor shall submit a certification by the bituminous paving material plant of conformance with all referenced standards.

The Contractor shall submit plant batch slips with each batch of bituminous paving material delivered to the work site to the Engineer.

E

PRODUCT

1. Bituminous Paving Materials

The Contractor shall ensure that all bituminous paving materials are supplied in accordance with *Section 401 – Plant Mix Pavements – General* and *Section 403 – Hot Bituminous Paving* of the current NHDOT Standard Specifications for Road and Bridge Construction. Specific types of bituminous paving materials to be placed shall be as specified on the Drawings or in the Standards Details.

The Contractor shall that ensure that bituminous paving materials meet all State and local requirements.

2. Aggregate Base Course Materials

The Contractor shall that ensure that all aggregate base course materials are supplied in accordance with *Division 300, Section 304 – Aggregate Base Course* of the current NHDOT Standard Specifications for Road and Bridge Construction.

F

EXECUTION

1. Placing Aggregate Base Course

- a. The Contractor shall ensure that all aggregate base course used as fill and backfill is the proper type for the pavement type it is designed to support. Backfill shall meet the requirements of *Section 01400 Earth Excavation, Backfill, Fill, and Grading*.
- b. The Contractor shall ensure that the aggregate base course surface is properly maintained in an undisturbed condition until the pavement has been placed. The Contractor shall ensure that any damaged or eroded aggregate base course is properly repaired and restored to grade before commencing paving operations.

2. Placing Bituminous Paving

- a. The Engineer shall inspect the bituminous paving material at the paving plant and determine its suitability for the project.
- b. The Contractor shall saw cut all existing pavement where it will match into the new pavement as indicate on the Drawings. The Contractor shall ensure that the saw cutting operations meet the requirements of *Section 628, Sawed Pavement* of the NHDOT Standard Specifications for Road and Bridge Construction.
- c. The Contractor shall place and compact bituminous paving at the thickness specified or as directed by the Engineer. The Contractor shall verify that the pavement has been compacted to the proper thickness once compaction operations have concluded.
- d. The Contractor shall ensure that the position of all manhole covers, catch basin grates, valve boxes, and similar Items in the paved area are adjusted as necessary to conform with the finished and base pavement grades or as directed by Engineer.
- e. The Contractor shall ensure that all joints between the existing pavement and the new pavement are tack coated in accordance with *Section 401* of the NHDOT Standard Specifications for Road and Bridge Construction.

PENNICHUCK WATER WORKS

- f. The Contractor shall furnish, install, maintain, and later remove all safety devices necessary to ensure public safety as they conduct their paving operations as required and in accordance with the Specifications.
- g. The Contractor shall ensure that all surplus and unsuitable materials are removed and disposed of properly.
- h. Core samples may be required to confirm the quality and design parameters of the bituminous paving materials. The Owner is responsible for the cost of taking and testing core samples. Failed core sample tests are the Contractor's responsibility.

[This page has been left intentionally blank]

SECTION 02400
Concrete Thrust Blocks

Table of Contents

A..... GENERAL
B..... RELATED WORK
C..... PRODUCT
D..... EXECUTION

A

GENERAL

The Contractor shall ensure that all mechanical joint fittings, including elbows, tees, hydrants, and branches, are protected against separation caused by unbalanced hydrostatic and hydrodynamic thrust forces. The Contractor shall supply all materials, labor, and equipment as required to install cast-in-place or precast concrete thrust blocks backed by undisturbed or properly compacted soil to ensure the integrity of the joint fittings at the locations indicated on the Drawings or as directed by the Engineer.

The Contractor shall ensure that cast-in-place or precast concrete thrust blocks meet the requirements of *ACI 304R-00 - Guide for Measuring, Mixing, Transporting, and Placing Concrete*.

All cast-in-place concrete thrust blocks shall be of the “mass” design utilizing no reinforcing steel, except for hooks as required for resistance-type thrust blocks.

B

RELATED WORK

Section 01400 Earth Excavation, Backfill, Fill and Grading

Section 01600 Water Main Pipe and fittings

Section 01900 Gravel Aggregate for Road Base and Water Main Backfill

C

PRODUCTS

1. Concrete Thrust Blocks

- a. All cast-in-place and precast concrete thrust blocks shall be fabricated with Type III A air-entrained portland cement and be plant-batched. The concrete shall be Class A with a minimum 28-day compressive strength of 3,000 psi, a maximum water/cement ratio (gallons per bag of cement) of 0.53 and a maximum slump no greater than 6 inches.

- b. All cast-in-place concrete thrust blocks shall be sized as designated on the Drawings, but no cast-in-place concrete thrust block shall have a volume of less than $\frac{3}{4}$ cubic yard.
- c. All precast concrete thrust blocks shall have the following minimum dimensions: 2-foot width \times 3-foot length \times 2-foot height, or as specified by the Owner's Representative.

D

EXECUTION

1. Installing Cast-in-Place Concrete Thrust Blocks

- a. The Contractor shall ensure that fresh concrete is placed within 1½ hours after mixing, with no water added to the mix at the job site. The Contractor shall ensure that the concrete's specified maximum water content is not exceeded.
- b. The Contractor shall ensure that the fresh concrete is placed such that it is not allowed to fall freely more than 5 feet to avoid aggregate segregation.
- c. The Contractor shall ensure that the fresh concrete is consolidated by spading or by mechanical vibration.
- d. The Contractor shall ensure that the fresh concrete has cured for at least one hour prior to commencing any backfilling operations. The concrete forms may be left in place while backfilling.

2. Installing Precast Concrete Thrust Blocks

- a. The Contractor shall ensure that precast concrete thrust blocks are installed directly behind the joint fitting it is restraining, with the face of the block at right angles to the total force vector.
 - i. The Contractor shall ensure that precast concrete thrust blocks are installed with aggregate base course between the thrust block and undisturbed earth. The Contractor shall ensure that the aggregate base course meet the requirements of *Section 01900 Gravel Aggregate for Road Base and Water Main Backfill*. The aggregate base course shall be placed in lifts that have a maximum thickness of 12 inches and compacted to a minimum Proctor of 95%. Hand tamping and rodding shall be used to drive the crushed gravel into all voids surrounding the thrust block.

[This page has been left intentionally blank]

SECTION 02450
Styrofoam Insulation

Table of Contents

A..... GENERAL
B..... RELATED WORK
C..... PRODUCT
D..... EXECUTION

A

GENERAL

All pipelines that have been buried with less than 4 feet of cover shall have Styrofoam™ board insulation mounted over the top of the water main to provide frost protection in accordance with the details on the Drawings.

Styrofoam board insulation shall be installed near all catch basins and storm drains to provide frost protection. Refer to *Standard Detail M16*, *Standard Detail M17*, *Standard Detail M18*, and *Standard Detail M19* for more information.

B

RELATED WORK

Section 01600 Water Main Pipe and Fittings

Section 01900 Gravel Aggregate for Road Base and Water Main Backfill

Section 02100 Sand

C

PRODUCT

1. Specifying Styrofoam Insulation Board Parameters

- a. All Styrofoam insulation used shall be board type, with a minimum thickness of 2 inches and minimum dimensions of 2 feet width × 8 feet length.
- b. All Styrofoam insulation used shall be closed cell, high density insulation suitable for direct burial in the ground.

D

EXECUTION

- a. The Contractor shall ensure that water mains buried less than 4 feet deep are first covered by a layer of properly compacted sand with a thickness of 6 inches. The Contractor shall then install Styrofoam insulation boards laid side-by-side to achieve a minimum width of 4 feet with staggered seams, centered over the water main.
 - i. The Contractor shall ensure that Styrofoam insulation boards are installed adjacent to catch basins and storm drains as shown on the Drawings. Aggregate base course may then be placed directly on the insulation and properly compacted for the roadway base.
 - ii. Styrofoam insulation shall be installed above all water service lines that run beneath driveways and parking lots.
 - iii. Styrofoam insulation shall be installed vertically at specified locations in the field as directed by the Owner's Representative.

[This page has been left intentionally blank]

SECTION 02500
Managing Water Flow During Construction

Table of Contents

A..... GENERAL
B..... RELATED WORK
C..... PRODUCT
D..... EXECUTION

A

GENERAL

The Contractor shall assume the responsibility of managing the flow of water and dewatering excavations at the work site during construction activities. The Contractor shall provide and deploy all necessary equipment and personnel, including pumping apparatus to accomplish this.

B

PERMITS

Permits for managing water flow during construction shall be obtained and paid for by the Contractor. Permits required may include the following:

- New Hampshire *RSA 485-A:17 – Terrain Alteration* (a site-specific permit concerning water quality)
- Construction Dewatering Permit
- EPA Dewatering Permit

C

EXECUTION

1. Dewatering Excavations

The Contractor shall ensure that all excavation work below ground water level is dewatered by approved methods to prevent saturated soil from flowing into the excavation, undermining existing structures, breaking up the naturally undisturbed earth in the banks, or loosening foundation materials. The Contractor shall lower the water level in advance of excavation and maintain a level such that any structures may be placed on a firm and dry foundation.

2. Deploying Pumping Apparatus

- a. The Contractor shall deploy personnel and pumping apparatus with adequate power and capacity to remove all water which may be encountered in their excavation work. The Contractor shall also keep additional pumps of sufficient power and capacity on hand and at the ready at the work site to provide backup for any unanticipated equipment breakdown or handle flooding issues.
 - i. The Contractor shall ensure that all pumped water is discharged at a location and in such a way that there is no adverse impact on the environment. If the water being discharged contains sediment, it shall be pumped through appropriately-sized erosion control facilities such as hay bales or silt fences.

3. Constructing and Maintaining Temporary Water Control Structures

- a. The Contractor shall develop Drawings and details for any temporary water control structures, especially in jacking and receiving pits, to the Owner's Representative for their review and approval. The Contractor shall submit their proposal for temporary water control structures at least two weeks in advance of any construction work.
 - i. The Contractor shall ensure that the construction of any temporary water control structures, the maintenance and proper operation of the same, and all other operations connected therewith, are carried out in a satisfactory manner. The Engineer may at any time require the Contractor to increase the precautions taken or to demand additional steps to make the temporary works adequate, substantial, and secure. Such directions or instructions given from time-to-time by the Engineer shall in no way relieve the Contractor from their entire responsibility for the efficiency and safety of these works.
 - ii. The Contractor shall make their own estimates of the necessary size, strength, and configuration of temporary water control structures, and shall assume all expenses and losses which may result from their inadequacy or from failure due to any cause whatsoever. Any work destroyed or damaged thereby shall be repaired or replaced by the Contractor at their expense.

4. Monitoring Water Turbidity

In waters that are used as a source of public water supply or used for trout, salmon, or other game or forage fish spawning or nursery, control measures must be adequate to assure that turbidity in the receiving water will not be increased more than allowed by applicable Federal, State, and local regulations.

[This page has been left intentionally blank]

SECTION 02550

Dust Control

Table of Contents

A..... GENERAL
B..... RELATED WORK
C..... PRODUCT
D..... EXECUTION

A

GENERAL

This section of the Specifications covers the control of dust with Calcium chloride and water.

B

RELATED WORK

Section 01400 Earth Excavation, Backfill, Fill and Grading

Section 01600 Water Main Pipe and Fittings

C

PRODUCTS

1. Calcium Chloride

- a. Calcium chloride used for dust control shall meet the requirements of *AASHTO M 144, Standard Specification for Calcium Chloride* and *ASTM D98, Standard Specification for Calcium Chloride*.
- b. Calcium chloride shall be securely packaged in moisture-proof bags marked with the following information:
 - Manufacturer
 - Product name
 - Net weight
 - Percentage of Calcium Chloride guaranteed by the manufacturer

- c. Calcium chloride shall be delivered to the work site in a dry condition. Calcium Chloride that has been improperly packaged, stored, or handled resulting in it becoming caked or sticky, or otherwise compromised by excessive moisture, shall be rejected for use by the Owner.

2. Water

Water used for dust control shall be clean, fresh not brackish, and free of any oils, acid or alkaline chemicals, vegetable matter, or other debris.

D

EXECUTION

1. Applying Calcium Chloride for Dust Control

- a. The Contractor shall apply Calcium chloride for dust control when ordered to do so by the Owner's Representative. The Contractor shall ensure that Calcium chloride is applied only in areas which will not be adversely affected by the application.
- b. The Contractor shall ensure that Calcium chloride is applied at a rate of 1½ pounds per square yard or at any other rate as directed by the Owner, using a mechanical spreader or other approved method. The number and frequency of Calcium chloride applications shall be determined by the Owner.

2. Spraying Water for Dust Control

- a. The Contractor shall ensure that water sprayed for dust control is dispersed through a nozzle with a minimum pressure of 20 psi gauge.
 - i. The Contractor shall use a sprayer with a nozzle-equipped spray bar that is connected to a water tank and a pump.
 - ii. The Contractor is responsible for the cost of water drawn from hydrants for use in dust control.

[This page has been left intentionally blank]

SECTION 02600
Work Site Clean Up

Table of Contents

A.....EXECUTION

A

EXECUTION

1. Conducting Work Site Clean Up Operations

- a. The Contractor shall ensure that the work site and adjacent areas are maintained in an orderly condition, and kept cleaned up, with all rubbish, surplus materials, and unneeded construction equipment removed as necessary. Any property damage caused by the Contractor's operations shall be repaired in a way that inconveniences the public and property owners as little as possible.
 - i. The Contractor shall ensure that any material or debris that has washed into or may be found in existing watercourses, ditches, gutters, drains, pipes, or other structures, and caused by the Contractor's work, is entirely removed and satisfactorily disposed of, in a timely manner. All ditches, channels, drains, pipes, and other structures shall be left in a clean and neat condition upon completion of the work.
 - ii. The Contractor shall ensure that, on or before the completion of the work, all temporary buildings and structures are removed, unless otherwise permitted in writing by the Owner's Representative. The Contractor shall ensure that all temporary works, tools, machinery, and any other construction equipment furnished by them is removed.
 - iii. The Contractor shall ensure that all rubbish generated by their operations is removed and properly disposed of in a roll-off container, daily. Roll-offs used shall be removed from the work area once they are filled. The Contractor shall ensure that all organic matter that may be found in, under, and around privies, houses, and other buildings used by them is removed, acceptably disinfected, and covered.
 - iv. The Contractor shall ensure that all roads, shoulders, grounds, and all parts of the premises and adjacent property affected by their operations are left in a neat and satisfactory condition, as required by the Contract and the approval of the Engineer. The Contractor shall ensure that all disturbed property is returned to its original grade and cover unless specified otherwise in the Drawings and Specifications or approved by the Engineer.

SECTION 02700
Measurement and Payment

Table of Contents

1 WATER MAIN
2 FITTINGS (FOR MAINS)
3 VALVES
4 SERVICES
5 HYDRANTS
6 EARTHWORK
7 MISCELLANEOUS
8 INTERIOR PLUMBING

GENERAL

The following subsections describe the measurement of and payment for the work to be done under the items listed in the Bid Schedule. Each unit or lump sum price stated in the Bid Schedule shall constitute full compensation as herein specified for each item of work completed in accordance with the Drawings and Specifications, including clean up.

After work is completed, the Owner's Representative shall make final measurements to determine the quantities of various items of work accepted as the basis for final settlement. The Contractor, in the case of unit price items, will be paid for the actual amount of work accepted and for the actual amount of materials in place, as shown by the final measurements.

SECTION NO. 1: WATER MAIN

ITEM NO. 1-X-YY: Water Main and Size

1. Method of Measurement:

- a. The length of pipe for water mains shall be measured by the linear foot along the horizontal centerline of the pipe including fittings.
- b. Measurement shall be along the water main installed and backfilled in the trench.
- c. Note:
 - i. X = Type of Pipe
 1. Ductile Iron
 2. PVC
 3. HDPE
 - ii. YY = Diameter of Pipe in inches
 - iii. Example: 12 inch Ductile Iron Water Main shall be represented as 1-1-12.

2. Basis of Payment:

- a. The unit price for this item shall constitute full compensation for all layout, saw cutting, labor, field cut pipe (gauge), materials and equipment necessary to excavate the trench and/or directional drilling pits for, install water main, backfill and compact the trench, and include restoration to subgrade.

- b. The cost of pressure testing and disinfecting the water main will account for 10% of this bid item and shall be retained until completion.

SECTION NO. 2: FITTINGS (FOR MAINS)

ITEM NO. 2-X-YY OR 2-X-YYxZZ: Fittings (For Mains) and Size

1. Method of Measurement:

- a. This item shall be paid for on a unit basis with a unit being one MJ fitting installed complete with retainer glands, 3/4" stainless steel threaded rod, hardware at each joint, and a precast thrust block as required on the plans and designated in the specifications.

- b. Note:

- i. X = Type of Fitting

- 1. Bend (all degrees)
 - 2. Solid Sleeve
 - 3. Coupling
 - 4. Reducer
 - 5. Tee
 - 6. Swivel Tee
 - 7. Foster Adapter
 - 8. Cap/Plug
 - 9. Stainless Steel Tapping Sleeve
 - 10. Ductile Iron Mechanical Joint Tapping Sleeve
 - 11. Steel Tapping Sleeve for 16-inch and 24-inch Asbestos Cement Pipe
 - 12. Blank

- ii. YY = Size of Fitting in inches

- iii. ZZ = Second dimension of the fitting in inches (Example: 12"x14" Reducer or 8"x6" Tee)

2. Basis of Payment:

- a. The unit price for this item shall include all labor, materials and equipment necessary to install the fitting as specified, including the excavation, backfill and restoration to the subgrade as designated on the Drawings.

SECTION NO. 3: VALVES

ITEM NO. 3-X-YY: Valve and Size

1. Method of Measurement:

- a. This item shall be measured and paid for on a unit basis with a unit being one either a MJ Valve or Air Release Assembly.
- b. MJ Valves are to be complete with retainer glands and 3/4" stainless steel threaded rod with stainless steel rod fittings at each joint and a valve box complete with cover as shown on the Drawings and designated in the Specifications.
- c. Air Release Assembly's are to be complete including, but not limited to Type K Copper tubing or CTS HDPE tubing, tapping saddle, CTPJ corporation stop, CTPJ x 90 degree bends, CTPJ x FIP adapter, MIP plug, CTPJ curb stop with operating rod and curb box assembly, gate box tops, stainless steel plastic tubing reinforcing inserts, rigid insulation panels and pressure treated blocking. All materials on *Standard Details M03 through M07* including the tapping sleeve and corporation shall be included in this bid item.
- d. Note:
 - i. X = Type of Valve
 1. Gate
 2. Butterfly
 3. Tapping
 4. Altitude
 5. Air Release Assembly
 6. Ball Valve
 7. Blank
 - ii. YY = Size of Valve in inches

2. Basis of Payment:

- a. The unit price for this item shall include all labor, materials and equipment necessary to install the valve as specified, including the excavation and backfill to designated subgrade and cover as designated in the Drawings.

SECTION NO. 4: SERVICES

ITEM NO. 4-1: Service Reconnection

1. Method of Measurement:

- a. This item shall be paid for on a unit basis and shall be installed as detailed on the Drawings and in the Specifications.

2. Basis of Payment:

- a. The unit price for this item shall include all the labor, materials and equipment necessary to reconnect an existing copper service from the existing water main to the new water main.
- b. The existing copper service shall be connected to a piece of new 1" Type K copper tubing that is tapped into the DIPCL or PVC water main with a corporation and tapping saddle (as required) as shown on the Drawings.
- c. This payment item shall include the installation of a 1" wet tap, a tapping saddle if required, 1" corporation, 1" type K copper from the corporation to the existing copper service, a Copper by Copper brass compression coupling, and the excavation and backfilling to sub grade as designated on the Drawings.
- d. The quantities of pipe, fittings, parts and labor associated with this work shall be compensated for in this payment item and shall not be compensated for under any other individual payment items for which they may otherwise be classified.

ITEM NO. 4-2-X-Y: Service Tubing

1. Method of Measurement:

- a. This item shall be paid for on a linear foot basis and shall be installed as shown on the Drawings and detailed in the Specifications.

b. Note:

- i. X = Type of Tubing
 - 1. Copper
 - 2. HDPE
 - 3. Blank
- ii. Y = Size of Tubing in inches

2. Basis of Payment:

- a. The unit price for this item shall constitute full compensation for all labor, materials and equipment necessary to excavate the trench, install, bed, and backfill the trench for the tubing as detailed on the Drawings and in the Specifications.

ITEM NO. 4-3-X: Curb Stop

1. Method of Measurement:

- a. This item shall be paid for on a unit basis with a unit being one curb stop complete with the valve box assembly installed and backfilled to subgrade as shown on the Drawings and detailed in the Specifications.

b. Note:

- i. $X = \text{Size of Curb Stop in inches}$

2. Basis of Payment:

- a. The unit price for this item shall include all labor, materials and equipment necessary to install a curb stop including the excavation, valve box assembly and backfill to subgrade as designated on the Drawings and in the Specifications.

ITEM NO. 4-4-X: Corporation Stop

1. Method of Measurement:

- a. This item shall be paid for on a unit basis with a unit being one corporation stop complete, installed, and backfilled to subgrade as shown on the plans and detailed in the specifications.

b. Note:

- i. $X = \text{Size of Corporation Stop in inches}$

2. Basis of Payment:

- a. The unit price for this item shall include all labor, materials and equipment necessary to install a corporation stop including the excavation and backfill to sub grade as designated on the Drawings and detailed in the Specifications.

ITEM NO. 4-5-X-YY or 4-5-X-YYxZZ: Fittings (For Services)

1. Method of Measurement:

a. This item shall be paid for on a unit basis with a unit being one copper or brass fitting installed complete with proper connection and required hardware as required on the Drawings and designated in the Specifications.

b. Note:

i. X = Type of Fitting

1. Bend (all degrees)
2. Tee
3. Female Adapter
4. Male Adapter
5. Cap/Plug
6. Union
7. Service Saddle
8. Blank

ii. YY = Size of Fitting in inches

iii. ZZ = Second dimension of the fitting in inches (Example: 2"x1" Tee)

2. Basis of Payment:

a. The unit price for this item shall include all labor, materials and equipment necessary to install the fitting as specified, including the excavation, backfill and restoration to the subgrade as designated on the Drawings.

ITEM NO. 4-6-X-Y: Service Replacements

1. Method of Measurement:

a. This pay item shall be measured on unit basis as shown in the Bid Schedule.

b. Note:

i. X = Type of Tubing

1. Copper
2. HDPE
3. Blank

ii. Y = Size of Tubing in inches

2. Basis of Payment:

- a. The unit price for this item shall constitute full compensation for all labor, materials, and equipment necessary to furnish and install a new service replacement and reconnect to an existing water service from the new water main to the service pipe complete with a new Curb Stop and Curb Box. Replacing the entire service located within the right of way.
- b. This item shall also include all the appropriate tubing, Tapping Saddles, Corporation Stop, Curb Stop, Curb Box, and couplings or unions and other accessories necessary to complete the reconnection.

SECTION NO. 5: HYDRANTS

ITEM NO. 5-1-X: Hydrants

1. Method of Measurement:

- a. This item shall be measured and paid for on a unit basis and shall be installed as detailed on the Drawings and in the Specifications.
- b. The other components of a hydrant assembly (anchor tee, pipe and gate valve) will be measured and paid for under their specific pay item.
- c. The payment item for a new hydrant shall include one new fire hydrant, precast thrust block, stone, specified MJ gland, plastic sheeting, stainless steel threaded rod with hardware, excavation and backfilling to the subgrade.
- d. The unit price for this item shall include all the labor, materials and equipment necessary to complete the installation of a new hydrant to a hydrant branch.
- e. Note:
 - i. X = Type of Hydrant Component
 1. New Hydrant
 2. Hydrant Reconnection
 3. Hydrant Extension

2. Basis of Payment:

- a. The unit price for this item shall include all labor, materials and equipment necessary to install the hydrant as specified, including the excavation and backfill to designated

subgrade and cover as designated in the Drawings and specified in the Specifications, or as directed by the Engineer.

SECTION NO. 6: EARTHWORK

SUBSECTION NO. 6-1: GRAVELS AND PAVEMENT

ITEM NO. 6-1-1: Bank Run Gravel

1. Method of Measurement

- a. This pay item shall be measured in cubic yards, linear feet, tons, or square yards as stated in the Bid Schedule.
- b. Bank run gravel shall be used to replace excavated material in locations as designated in the Drawings.
- c. Cubic yard quantities shall be calculated using the average end area method. All materials shall be in place and compacted. Only when agreed upon with the Engineer, truck measurement quantities can be utilized in lieu of the average end area method. Truck quantities shall be deducted by 20% to compensate for loss in volume associated with compaction.
- d. Linear feet shall be measured along the length of water main installation or as designated on the Drawings.
- e. Tonnage quantities will require individual weight slips for each truck shipment to the project. These tickets shall be given to the Engineer on a daily basis. All weight slips must be performed on scales sealed by the appropriate governmental authority.
- f. Square yards shall be measured along the length of the water main multiplied by the approved payment width as depicted on the Drawings.

2. Basis of Payment

- a. The unit price of this item shall be considered full compensation for the furnishing of all materials, labor, equipment and tools necessary for furnishing, placing, grading, and compacting bank run gravel.
- b. The unit price of this item shall also be considered full compensation for the furnishing of all materials, labor, equipment and tools necessary for excavating areas requiring placement, grading, and compaction of bank run gravel.

ITEM NO. 6-1-2: Processed Gravel

1. Method of Measurement

- a. This pay item shall be measured in cubic yards, linear feet, tons, or square yards as stated in the Bid Schedule.
- b. Processed Gravel shall be used to replace excavated material in locations as designated in the Specifications or Drawings.
- c. Cubic yard quantities shall be calculated using the average end area method. All materials shall be in place and compacted. Only when agreed upon with the Engineer, truck measurement quantities can be utilized in lieu of the average end area method. Truck quantities shall be deducted by 20% to compensate for loss in volume associated with compaction.
- d. Linear feet shall be measured along the length of water main installation or as designated on the Drawings.
- e. Tonnage quantities will require individual weight slips for each truck shipment to the project. These tickets shall be given to the Engineer on a daily basis. All weight slips must be performed on scales sealed by the appropriate governmental authority.
- f. Square yards shall be measured along the length of the water main multiplied by the approved payment width as depicted on the Drawings.

2. Basis of Payment

- a. The unit price of this item shall constitute full compensation for the furnishing of all materials, labor, equipment, and tools necessary for furnishing, placing, grading, and compacting processed gravel as specified.
- b. The unit price of this item shall also be considered full compensation for the furnishing of all materials, labor, equipment and tools necessary for excavating areas requiring placement, grading, and compaction of processed gravel.
- c. This item shall include materials, labor, tools, and equipment required to establish final grading so that bituminous pavement can be constructed to the grades and elevations shown on the Drawings.

ITEM NO. 6-1-3: Machine Placed Temporary Trench Patch

1. Method of Measurement

- a. This pay item shall be measured in linear feet, tons, or square yards as stated in the Bid Schedule.
- b. Linear feet shall be measured along the length of the water main installation or as designated on the Drawings.
- c. Tonnage quantities will require individual weight slips for each truck shipment to the project. These tickets shall be given to the Engineer on a daily basis. All weight slips must be performed on scales sealed by the appropriate governmental authority.
- d. Square yards shall be measured along the length of the water main multiplied by the approved payment width as depicted on the Drawings.

2. Basis of Payment

- a. This item shall constitute full compensation for all materials, labor, equipment, and tools necessary for installation of temporary trench patch including pavement and underlying gravels, unless provided for under a separate item.
- b. Pavement outside the limits shown on the Drawings that is cracked, broken, or otherwise damaged, as a result of the Contractor's operations, shall be repaired by the Contractor at no additional cost to the Owner.
- c. This pay item requires individual weight slips.

ITEM NO. 6-1-4: Machine Placed Permanent Trench Patch

1. Method of Measurement

- a. This pay item shall be measured in linear feet, tons, or square yards as stated in the Bid Schedule.
- b. Linear feet shall be measured along the length of the water main installation or as designated on the Drawings.
- c. Tonnage quantities will require individual weight slips for each truck shipment to the project. These tickets shall be given to the Engineer on a daily basis. All weight slips must be performed on scales sealed by the appropriate governmental authority.

- d. Square yards shall be measured along the length of the water main multiplied by the approved payment width as depicted on the Drawings.

2. Basis of Payment

- a. The unit price for this item shall include all labor and equipment necessary to sawcut existing asphalt, fine grade and furnish and install asphalt.
- b. Pavement outside the limits shown on the Drawings that is cracked, broken, or otherwise damaged, as a result of the Contractor's operations, shall be repaired by the Contractor at no additional cost to the Owner.
- c. This pay item requires individual weight slips.

ITEM NO. 6-1-5: Machine Placed Bituminous Base Course

1. Method of Measurement

- a. This pay item shall be measured in linear feet, tons, or square yards as stated in the Bid Schedule.
- b. Linear feet shall be measured along the length of the water main installation or as designated on the Drawings.
- c. Tonnage quantities will require individual weight slips for each truck shipment to the project. These tickets shall be given to the Engineer on a daily basis. All weight slips must be performed on scales sealed by the appropriate governmental authority.
- d. Square yards shall be measured along the length of the water main multiplied by the approved payment width as depicted on the Drawings.

2. Basis of Payment

- a. The unit price for this item shall include all labor and equipment necessary to sawcut existing asphalt, fine grade and furnish and install asphalt.
- b. Pavement outside the limits shown on the Drawings that is cracked, broken, or otherwise damaged, as a result of the Contractor's operations, shall be repaired by the Contractor at no additional cost to the Owner.
- c. This pay item requires individual weight slips.

ITEM NO. 6-1-6: Machine Placed Bituminous Surface Course

1. Method of Measurement

- a. This pay item shall be measured in linear feet, tons, or square yards as stated in the Bid Schedule.
- b. Linear feet shall be measured along the length of the water main installation or as designated on the Drawings.
- c. Tonnage quantities will require individual weight slips for each truck shipment to the project. These tickets shall be given to the Engineer on a daily basis. All weight slips must be performed on scales sealed by the appropriate governmental authority.
- d. Square yards shall be measured along the length of the water main multiplied by the approved payment width as depicted on the Drawings.

2. Basis of Payment

- a. The unit price for this item shall include all labor and equipment necessary to sawcut existing asphalt, fine grade and furnish and install asphalt.
- b. Pavement outside the limits shown on the Drawings that is cracked, broken, or otherwise damaged, as a result of the Contractor's operations, shall be repaired by the Contractor at no additional cost to the Owner.
- c. This pay item requires individual weight slips.

ITEM NO. 6-1-7: Hand Placed Hot Bituminous Pavement

1. Method of Measurement

- a. This pay item shall be measured in linear feet, tons, or square yards as stated in the Bid Schedule.
- b. Linear feet shall be measured along the length of the water main installation or as designated on the Drawings.
- c. Tonnage quantities will require individual weight slips for each truck shipment to the project. These tickets shall be given to the Engineer on a daily basis. All weight slips must be performed on scales sealed by the appropriate governmental authority.

- d. Square yards shall be measured along the length of the water main multiplied by the width as depicted on the Drawings, or as directed by the Engineer.

2. Basis of Payment

- a. The unit price for this item shall constitute full compensation for furnishing all materials, labor, equipment, saw cutting, and tools necessary to furnish, place, grade, compact, and install hot bituminous pavement.

ITEM NO. 6-1-8: Mill Existing Pavement

1. Method of Measurement

- a. This pay item shall be measured in linear feet or square yards as stated in the Bid Schedule.
- b. Linear feet shall be measured along the length of water main installation, as designated on the Drawings, or as directed by the Engineer.
- c. Square yards shall be measured along the length of the water main multiplied by the approved payment width as depicted on the Drawings, or as directed by the Engineer.
- d. The milling area shall be to the specified length and width as shown on the Drawings or as directed by the Engineer.

2. Basis of Payment

- a. The unit price for this item shall constitute full compensation for furnishing all materials, labor, equipment, and tools necessary to mill the existing pavement as shown on the Drawings or directed by the Engineer.

ITEM NO. 6-1-9: Install Reclaimed Material

1. Method of Measurement

- a. This item shall be measured in either cubic yards, square yards, linear feet, or tons as stated in the Bid Schedule.
- b. Linear feet shall be measured along the length of water main installation, as designated on the Drawings, or as directed by the Engineer.
- c. Square yards shall be measured along the length of the water main multiplied by the approved payment width as depicted on the Drawings, or as directed by the Engineer.

- d. Cubic yard quantities shall be calculated using the average end area method. All materials shall be in place and compacted. Only when agreed upon with the Engineer, truck measurement quantities can be utilized in lieu of the average end area method. Truck quantities shall be deducted by 20% to compensate for loss in volume associated with compaction.
- e. Tonnage quantities will require individual weight slips for each truck shipment to the project. These tickets shall be given to the Engineer on a daily basis. All weight slips must be performed on scales sealed by the appropriate governmental authority.
- f. Installation of reclaimed material shall be to the specified depth and width as shown on the Drawings or as directed by the Engineer.

2. Basis of Payment

- a. This item shall include full compensation for uniformly grading the reclaimed asphalt to the depth and grades shown on the Drawings or as directed by the Engineer.
- b. This item shall include stock piling and protection of material against segregation or contamination by other materials deemed unsuitable for road reconstruction. Material shall be re-handled once the road subgrade is established.

ITEM NO. 6-1-10: Asphalt Reclamation

1. Method of Measurement:

- a. Asphalt reclamation shall be measured in either square yards or linear feet as stated in the Bid Schedule.
- b. Linear feet shall be measured along the length of water main installation, as designated on the Drawings, or as directed by the Engineer.
- c. Square yards shall be measured along the length of the water main installed multiplied by the approved payment width as depicted on the Drawings, or as directed by the Engineer.
- d. The roadway pavement shall be reclaimed to the specified depth and width as shown on the Drawings or as directed by the Engineer.

2. Basis of Payment:

- a. This item shall include full compensation for protection of existing structures or utilities, or the furnishing of all materials, labor, equipment and tools necessary for constructing the pavement reclamation.
- b. This item shall include full compensation for the protection of existing structures and utilities; or lowering existing utility structures to a depth below the existing pavement and gravel materials to be pulverized.

ITEM NO. 6-1-11: Crushed Gravel for Shoulder Leveling

1. Method of Measurement:

- a. This pay item shall be measured in linear feet.
- b. The measurement shall be taken along the center line of the road regardless if gravels are needed on one side or both sides of the road.

2. Basis of Payment:

- a. The unit price of this item shall constitute full compensation for the furnishing of all materials, labor, equipment, and tools necessary for furnishing, placing, grading, and compacting crushed gravel as specified.

ITEM NO. 6-1-12: City of Nashua Final Trench Restoration - Low Traffic

1. Method of Measurement

- a. This pay item shall be measured in linear feet.
- b. Linear feet shall be measured along the length of water main installation or as designated on the Drawings.

2. Basis of Payment

- a. The unit price of this item shall be considered full compensation for the furnishing of all materials, labor, equipment and tools necessary to remove/excavate the existing asphalt and gravel materials and replace them as detailed on the Drawings.
- b. Should it be necessary for the Contractor to construct and repave a wider trench, the Contractor may do so but no extra compensation shall be awarded unless the circumstances

that created the need for the trench widening are beyond the control of the Contractor and the Contractor has received the approval of the Engineer.

- c. The quantities of labor, equipment and materials associated with this work shall be compensated for in this pay item and shall not be compensated for under any other individual payment items for which they may otherwise be classified.

ITEM NO. 6-1-13: City of Nashua Final Trench Restoration - High Traffic

1. Method of Measurement:

- a. This pay item shall be measured in linear feet.
- b. Linear feet shall be measured along the length of water main installation or as designated on the Drawings.

2. Basis of Payment:

- a. The unit price of this item shall be considered full compensation for the furnishing of all materials, labor, equipment and tools necessary to remove/excavate the existing asphalt and gravel materials and replace them as detailed on the Drawings.
- b. Should it be necessary for the Contractor to construct and repave a wider trench, the Contractor may do so but no extra compensation shall be awarded unless the circumstances that created the need for the trench widening are beyond the control of the Contractor and the Contractor has received the approval of the Engineer.
- c. The quantities of labor, equipment and materials associated with this work shall be compensated for in this pay item and shall not be compensated for under any other individual payment items for which they may otherwise be classified.

ITEM NO. 6-1-14: City of Nashua Moratorium Type 6 Trench Restoration – Partial

1. Method of Measurement:

- a. This pay item shall be measured in linear feet.
- b. Linear feet shall be measured based on the length of the area designated on the Drawings.

2. Basis of Payment:

- a. The unit price of this item shall be considered full compensation for the furnishing of materials, labor, equipment and tools necessary to remove/excavate the existing asphalt and gravel materials and replace them as detailed on the Drawings.

- b. Should it be necessary for the Contractor to construct and repave a wider trench, the Contractor may do so but no extra compensation shall be awarded unless the circumstances that created the need for the trench widening are beyond the control of the Contractor and the Contractor has received the approval of the Engineer.
- c. The quantities of labor, equipment and materials associated with this work shall be compensated for in this pay item and shall not be compensated for under any other individual payment items for which they may otherwise be classified.

ITEM NO. 6-1-15: City of Nashua Moratorium Type 7 Trench Restoration – Full

1. Method of Measurement:

- a. This pay item shall be measured in linear feet.
- b. Linear feet shall be measured based on the length of the area designated on the Drawings.

2. Basis of Payment:

- a. The unit price of this item shall be considered full compensation for the furnishing of materials, labor, equipment and tools necessary to remove/excavate the existing asphalt and gravel materials and replace them as detailed on the Drawings.
- b. Should it be necessary for the Contractor to construct and repave a wider trench, the Contractor may do so but no extra compensation shall be awarded unless the circumstances that created the need for the trench widening are beyond the control of the Contractor and the Contractor has received the approval of the Engineer.
- c. The quantities of labor, equipment and materials associated with this work shall be compensated for in this pay item and shall not be compensated for under any other individual payment items for which they may otherwise be classified.

SUBSECTION NO. 6-2: Pavement Markings

ITEM NO. 6-2-1-X: Retroreflective Painted Pavement Markings

1. Method of Measurement:

- a. Retroreflective painted markings shall be measured in linear feet, square feet or a lump sum basis as stated in the Bid Schedule.
- b. Linear feet shall be measured lengthwise along the center of the pavement marking. Double lines and combination solid/broken lines will be measured as separate lines according to the length of each individual line.

- c. Square feet shall be measured lengthwise along the center of the pavement marking times the width of the marking as required on the Drawings or Specifications.
- d. Note:
 - i. $X = \text{Width of Marking in inches}$

2. Basis of Payment:

- a. The unit price shall include all labor, materials and equipment to clean, prepare and apply marking to surface per NHDOT Specifications.

ITEM NO. 6-2-2-X: Retroreflective Thermoplastic Pavement Markings

1. Method of Measurement:

- a. Retroreflective thermoplastic markings shall be measured in square feet or a lump sum basis as stated in the Bid Schedule.
- b. Square feet shall be measured lengthwise along the center of the pavement marking multiplied by the width of the marking as required on the Drawings or Specifications, or as directed by the Engineer.
- c. Note:
 - i. $X = \text{Width of Marking in inches}$

2. Basis of Payment:

- a. The unit price shall include all labor, materials and equipment to clean, prepare and apply marking to surface per NHDOT Specifications.

ITEM NO. 6-2-3-X: Obliterate Pavement Markings

1. Method of Measurement:

- a. Obliterate pavement markings lines shall be measured by the linear foot with no adjustment to width. The marking to be removed will be measured along the center of the marking.
- b. Obliterate pavement marking symbols or words shall be measured by the square foot. Square feet shall be measured along the center of the symbol/word multiplied by the width of the marking.

c. Note:

- i. X = Type of Removal
 1. Pavement Marking Line
 2. Pavement Marking Symbol/Word

2. Basis of Payment:

- a. The unit price shall include all labor, materials and equipment to remove markings from pavement surface per NHDOT Specifications. Payment will not be made for removal of removable pavement marking tape.

SUBSECTION NO. 6-3: EXCAVATION

ITEM NO. 6-3-1: Trench Ledge Excavation and Disposal

1. Method of Measurement:

- a. Trench Ledge Excavation and Disposal shall be measured on a cubic yard basis, as uncovered in the field. Ledge quantities shall not be removed until measurements have been verified by the Owner.
- b. Cubic yards shall be measured from the top of ledge to the required trench depth at a trench width as depicted in Specification Section 01500.

2. Basis of Payment:

- a. This pay item shall include all means necessary to remove and dispose of all ledge including, but not limited to blasting. This pay item shall also incorporate the costs of backfilling the voids left by rock removal.

ITEM NO. 6-3-2: Boulder Excavation and Disposal

1. Method of Measurement:

- a. Boulder Excavation and Disposal shall be measured on a cubic yard basis, as uncovered in the field. Payment shall only be made for boulders measuring greater than one cubic yard in volume.
- b. Cubic yards shall be measured by taking the average length, width, and depth of the boulder as measured by the Engineer.

2. Basis of Payment:

- a. This pay item shall include all means necessary to remove and dispose of all boulders including, but not limited to blasting. This pay item shall also incorporate the costs of backfilling the voids left by boulder removal.

ITEM NO. 6-3-3: Test Pit Excavation

1. Method of Measurement:

- a. This item shall be paid for on a cubic yard basis and shall be executed as shown in the Drawings and detailed in the Specifications.

2. Basis of Payment:

- a. This payment item shall include all labor, materials and equipment necessary to excavate, backfill, shore, plate and locate the existing water main and other utilities that may conflict with the water main construction. Excluding gravels and pavement restoration, this payment item will encompass all situations involved in the exploratory excavation process.
- b. The quantities of labor, equipment and materials associated with this work shall be compensated for in this payment item and shall not be compensated for under any other individual payment items for which they may otherwise be classified.

SUBSECTION NO. 6-4: SOILS

ITEM NO. 6-4-1-1: Unsuitable Materials Above Pipe Bedding Subgrade

1. Method of Measurement:

- a. Payment for unsuitable materials shall be on an in place cubic yard basis.
- b. This item shall be measured based on in place cubic yards of unsuitable materials above the pipe bedding subgrade, which are removed from the trench, and located within trench payment widths per Pennichuck *Standard Detail M02*.
- c. Unsuitable soils limits shall be as directed and approved by the Engineer. Final measurements shall be agreed upon on a daily basis.

2. Basis of Payment:

- a. The cost shall include all labor, equipment and materials necessary for the removal of the unsuitable material and replacement of material in accordance with Specification Section 01400.
- b. Compensation for pipe bedding sand or roadway gravels should not be factored in this cost.

ITEM NO. 6-4-1-2: Unsuitable Materials Below Pipe Bedding Subgrade

1. Method of Measurement:

- a. Payment for unsuitable materials shall be on an in place cubic yard basis.
- b. This item shall be measured based on in place cubic yards of unsuitable materials below pipe bedding subgrade, which are removed from the trench, and located within the trench payment widths per Pennichuck *Standard Detail M02*.
- c. Unsuitable soils limits shall be as directed and approved by the Engineer. Final measurements shall be agreed upon on a daily basis.

2. Basis of Payment:

- a. The cost shall include all labor, equipment and materials necessary for the removal of the unsuitable material and replacement of material in accordance with Specification Section 01400.
- b. Compensation for unsuitable materials below pipe bedding subgrade shall include the replacement materials per Pennichuck *Standard Detail M02*.

ITEM NO. 6-4-2: Erosion Control

1. Method of Measurement:

- a. Erosion Control shall be paid on a unit, linear foot, or lump sum basis as stated in the Bid Schedule and as shown on the Drawings.

2. Basis of Payment:

- a. If Erosion Control is paid for on a lump sum basis, it shall be paid as 50% of the amount shall be released when the project is 25% complete, less the 10% retainage. The remainder shall be released at substantial completion, less the retainage.

- b. This pay item shall be considered full compensation for all materials, labor and equipment necessary for the installation of erosion, sediment control and storm water management devices, the maintenance of the same in good working order, and replacement of any devices damaged or filled with sediment.

ITEM NO. 6-4-3: SWPPP and Monitoring

1. Method of Measurement:

- a. Storm Water Pollution Protection Plan and Monitoring shall be paid on a lump sum basis. The Contractor is responsible for the NOI, SWPPP monitoring and inspection reports.
- b. Measurement for monitoring will be made based on the percentage of work completed at each payment requisition.

2. Basis of Payment:

- a. The price for this item shall be considered full compensation for development of a detailed plan that shows the location of all erosion and storm water control devices including sedimentation basins, sediment collection bags, etc., for construction dewatering discharges necessary to complete the work. The plan shall include appropriate phases that are keyed to specific project milestones.

SUBSECTION NO. 6-5: LANDSCAPING

ITEM NO. 6-5-1: Clearing and Grubbing

1. Method of Measurement:

- a. This item will be paid for on either a lump sum or acreage basis as shown in the Bid Schedule and on the Drawings.

2. Basis of Payment:

- a. This item shall include all labor, materials and equipment necessary to clear and grub the land as designated on the Drawings. This pay item includes tree and stump removal within the designated area. This clearance shall be shown in the Drawings or directed by the Engineer.

ITEM NO. 6-5-2-X: Tree and Stump Removal

1. Method of Measurement:

- a. This item shall be measured and paid for on either a lump sum or unit basis, as stated in the Bid Schedule.
- b. The diameter of the tree shall be measured 4' off the existing grade at the base of the tree.
- c. Note:
 - i. $X = \text{Diameter of Tree in inches}$

2. Basis of Payment:

- a. Tree and stump removal shall include all labor and equipment necessary to remove trees and stumps and properly dispose of them off-site.

ITEM NO. 6-5-3: Landscaping Remediation

1. Method of Measurement:

- a. This item will be measured and paid for on a project basis as shown in the Bid Schedule.

2. Basis of Payment:

- a. This item shall include all labor, materials and equipment necessary to repair the disturbed area to its pre-construction conditions.
- b. The Contractor shall be responsible for coordinating with a subcontractor relative to the type of work to be performed and obtain a quote for any item which will exceed \$1,000.00 per address.
- c. This item shall only be used with approval from the Engineer or Owner.

ITEM NO. 6-5-4: Loam and Seed

1. Method of Measurement:

- a. Loam and seed shall be measured and paid for on a lump sum, square yard, or linear foot basis in accordance with the detail depicted on the Drawings.
- b. Linear feet shall be measured along the length of water main installation or as designated on the Drawings.
- c. Square yards shall be measured along the length of the water main multiplied by the approved payment width as depicted on the Drawings.

2. Basis of Payment:

- a. The unit price for this item shall include all labor, materials and equipment necessary to restore and stabilize all disturbed areas not restored by other pay items.
- b. Payment will be made for 60% of the bid item value upon completion of topsoil installation and hydroseeding. The remaining 40% of the bid item value will be paid after 85% of grass growth has been established.

ITEM NO. 6-5-5-X: Tree and Shrub Replacement

1. Method of Measurement:

- a. This item shall be paid for on a lump sum or unit basis as stated in the Bid Schedule.

b. Note:

- i. X = Species of Tree or Shrub
 - 1. Species 1
 - 2. Species 2
 - 3. Species 3
 - 4. Species 4
 - 5. Species 5
 - 6. Species 6
 - 7. Species 7
 - 8. Species 8

2. Basis of Payment:

- a. This item shall include all labor, materials and equipment necessary to furnish and install trees and shrubs.
- b. This item shall only be used with approval from the Engineer or Owner.

SECTION NO. 7: MISCELLANEOUS

SUBSECTION NO. 7-1: PRECONSTRUCTION

ITEM NO. 7-1-1: Preconstruction Video Documentation

1. Method of Measurement:

- a. This item shall be paid for on a lump sum basis as stated in the Bid Schedule.

2. Basis of Payment:

- a. Payment for this item will be made upon acceptance of the Video Documentation by Pennichuck after review and confirmation that the video clearly depicts the entire proposed work area.
- b. The quantities of labor associated with this work shall be compensated for in this payment item and shall not be compensated for under any other individual payment items for which they may otherwise be classified.

ITEM NO. 7-1-2: Mobilization and Demobilization

1. Method of Measurement:

- a. This item shall be paid for on a lump sum basis.
- b. This payment item shall include the costs associated with obtaining the required insurances, building permits, street permits, traffic signage and mobilizing/demobilizing equipment and materials to/from the job site.

2. Basis of Payment:

- a. This item shall not exceed 5% of the total project bid. Should the value of this item exceed 5% of the total project bid, the amount greater than the 5% will be paid upon final completion.
- b. Payment shall be made as follows: 75% of this bid item value (within the 5%) can be released upon initial mobilization, less retainage. After substantial completion, 100% of this bid item (within the 5%) will be released, less the retainage.

ITEM NO. 7-1-3: Vibration, Seismic, and/or Acoustic Monitoring

1. Method of Measurement:

- a. This item shall be paid for on an hourly basis.
- b. The Engineer or Owner must approve use of vibration monitoring prior to installation of monitoring devices. Vibration monitoring initialized prior to Engineer's approval will not be eligible for payment.
- c. Monitoring shall be performed by a qualified Vibration, Seismic, and/or Acoustic Consultant.

2. Basis of Payment:

- a. Payment for monitoring shall be based on actual invoices from the Subcontractor and submitted to the Engineer. Payment shall be without markup.
- b. The payment shall constitute full compensation for the furnishing of all labor, equipment and materials associated with providing monitoring services in accordance with the Drawings and Specifications.
- c. This payment shall include, but not be limited to; coordination, scheduling, and payment for all services; providing support services for the vibration monitoring firm; and all other work required for or incidental to the satisfactory completion of this item.

SUBSECTION NO. 7-2: POST CONSTRUCTION

ITEM NO. 7-2-1: Reset Property Boundaries

1. Method of Measurement:

- a. This item shall be measured and paid for on a unit basis to reset property boundary markers disturbed during construction.

2. Basis of Payment:

- a. The unit price for this item shall include all labor, materials and equipment necessary to reset a property boundary to the original location with a licensed surveyor.

SUBSECTION NO. 7-3: INSTALLATION OF METER PIT

ITEM NO. 7-3-1: Residential Meter Pit

1. Method of Measurement:

- a. This item shall be measured and paid for on a unit basis.

2. Basis of Payment:

- a. The unit price for this item shall include all labor, materials and equipment necessary to install a residential meter pit.

ITEM NO. 7-3-2: Master Meter Pit

1. Method of Measurement:

- a. This item shall be measured and paid for on a unit basis.

2. Basis of Payment:

- a. The unit price for this item shall include all labor, materials and equipment necessary to install a master meter pit.

SUBSECTION NO. 7-4: ELECTRICAL INSTALLATIONS

ITEM NO. 7-4-1-X: Communications Conduit

1. Method of Measurement:

- a. This item shall be paid for on either a linear foot or lump sum basis as stated in the Bid Schedule.
- b. Linear feet shall be measured along the length of conduit installation or as designated on the Drawings, or as directed by the Engineer.
- c. Note:
 - i. $X = \text{Size of Conduit in inches}$

2. Basis of Payment:

- a. The unit price for this item shall include all labor, materials and equipment necessary to excavate the trench, install communications conduit, backfill and compact the trench, and restore the area to subgrade.

ITEM NO. 7-4-2: Pull Boxes for Communications Conduit

1. Method of Measurement:

- a. This item shall be paid for on a unit basis as stated in the Bid Schedule.

2. Basis of Payment:

- a. The unit price for this item shall include all labor, materials and equipment necessary to excavate the trench, install a pull box, backfill and compact the trench, and restore the area to subgrade.

ITEM NO. 7-4-3: Electrical Panel and Meter Socket

1. Method of Measurement:

- a. This item shall be paid for on a lump sum basis.

2. Basis of Payment:

- a. The unit price for this item shall include all labor, materials and equipment necessary to install an electrical panel and meter socket.

SUBSECTION NO. 7-5: TRAFFIC

ITEM NO. 7-5-1-X: Traffic Control

1. Method of Measurement:

- a. Maintenance of Traffic shall be paid on a lump sum basis for the entire project and shall include traffic signage and roadway maintenance.
- b. Police Officer with Cruiser (7-5-1-2, Hourly). The Contractor will be responsible to coordinate and pay the Municipality directly for a Police Detail with Cruiser and will be reimbursed for the total hours that the Police Detail is required on project.
- c. Police Officer with a Cruiser (7-5-1-3, Allowance) The Contractor will be responsible to coordinate and pay the Municipality directly for a Police Detail with Cruiser and will be reimbursed for the total cost of the invoices for the police detail. Measurement for the Police Officer shall be based on cost of the approved invoices submitted.
- d. Certified Flaggers shall be paid on an hourly basis for the hours of actual work performed, measured to the nearest ¼ hour. Overtime rate shall be factored in this unit cost. The total hours requested will be based on daily tickets, invoices or certified payroll depicting the hours the Certified Flagger worked.

e. Note:

- i. X = Type of Traffic Control
 - 1. Maintenance of Traffic
 - 2. Police Officer with Cruiser (Hourly)
 - 3. Police Officer with Cruiser (Allowance)
 - 4. Certified Flagger

2. Basis of Payment:

- a. Maintenance of Traffic (7-5-1-1) shall be paid on a lump sum basis. 50% of the lump sum value shall be released when the contract value is 25% complete. The remaining 50% of the lump sum value shall be released at substantial completion.

PENNICHUCK WATER WORKS

- i. Traffic Signage shall include all temporary signage, cones, barrels and barricades to maintain a safe road during construction and all signage associated with the Contractor's detour package.
 - ii. Roadway maintenance shall include ditch restoration, dust control and grading of trenches during construction in a condition acceptable to the Owner.
- b. Police Officer with Cruiser (7-5-1-2, Hourly) shall be totals hours approved for the Police Detail multiplied by the Bid hourly unit price.
- c. Police Officer with Cruiser (7-5-1-3, Allowance) shall be reimbursed per the actual cost of the invoice associated with the Police Detail and approved by the engineer for that project. Contractor markup of the invoices is not allowed.
- d. Traffic Control, Certified Flagger (7-5-1-4) shall be totals hours approved for the flagger multiplied by the Bid hourly unit price. This shall include means of communications, signage and appropriate safety apparel.

ITEM NO. 7-5-2: Portable Message Sign

1. Method of Measurement:

- a. The portable changeable message sign shall be per NHDOT specifications and will be paid for on a monthly basis as directed by the Owner.

2. Basis of Payment:

- a. This item shall be paid for on a monthly basis and include the cost to relocate, secure and maintain during the course of the project.

ITEM NO. 7-5-3: Traffic Signalization

1. Method of Measurement:

- a. This item shall be paid for on a lump sum basis as stated in the Bid Schedule.

2. Basis of Payment:

- a. This item shall include all labor, materials and equipment necessary to install or repair traffic signalization.

SUBSECTION NO. 7-6: TEMPORARY WATER

ITEM NO. 7-6-1: Temporary Water Main

1. Method of Measurement:

- a. This item shall be paid for on a lump sum basis and shall be installed as shown on the Drawings and detailed in the Specifications.

2. Basis of Payment:

- a. The lump sum for this item shall include all labor, materials and equipment necessary to install and maintain the temporary water main and temporary water main connections to existing water mains and hydrants as shown on the plans. This pay item shall include the installation, disinfection, maintenance, removal of the temporary water main, and restoration of the disturbed area.

ITEM NO. 7-6-2-X: Temporary Water Service

1. Method of Measurement:

- a. This item shall be paid for on a unit basis and shall be installed as detailed on the Drawings and in the Specifications.

b. Note:

- i. X = Type of Temporary Water Service
 1. Type 1
 2. Type 2
 3. Type 3
 4. Type 4

2. Basis of Payment:

- a. The unit price for this item shall include all the labor, materials and equipment necessary to temporarily connect an existing property to the temporary water main. Also included is the labor and equipment necessary to install the temporary water service underground where necessary and any other efforts associated with installing the pipe so as not to create hazard to pedestrian or vehicular traffic. Temporary water connections are to be installed in advance of water main construction. Temporary water services will not be initiated until successful bacteria testing of the temporary water main has been completed.

SUBSECTION NO. 7-7: INSULATION

ITEM NO. 7-7-1: Rigid Insulation Board

1. Method of Measurement:

- a. This item shall be paid for on a unit basis with one unit being a closed cell high density rigid Styrofoam insulation board that is 2 in thick by 2 ft wide and 8 ft long.
- b. Rigid insulation board shall be placed over any water main, services, or fittings that have less than 5 feet of cover on all sides or as directed by the Engineer and shown on the Drawings.

2. Basis of Payment:

- a. This item shall include all labor and materials necessary to install high density rigid Styrofoam insulation over, under or adjacent to the water main, services, or fittings in the vicinity of catch basins, drain pipes, and other locations as directed by the Engineer and as depicted in the Specifications.

SUBSECTION NO. 7-8: REPLACEMENT OF SIDEWALK AND CURBS

ITEM NO. 7-8-1-X: Curb

1. Method of Measurement:

- a. New Asphalt Curb (7-8-1-1) and New Granite Curb (7-8-1-3) shall be measured per linear foot of new vertical, radial or sloped curb installed as shown on the Drawings or where directed by the Engineer.
- b. Remove and Reset Granite Curb (7-8-1-2) shall be measured per linear foot of vertical, radial or sloped curb removed, regardless of type or size, protected and reset as shown on the Drawings or where directed by the Engineer.
- c. Measurement shall be along the centerline of the curb, to the nearest linear foot.
- d. Note:
 - i. X = Type of Curb
 1. New Asphalt Curb
 2. Remove and Reset Granite Curb
 3. New Granite Curb

2. Basis of Payment:

- a. This item shall be paid for at the Contract unit price per linear foot.
- b. This unit price shall constitute full compensation for the furnishing of all materials, labor, equipment, and tools necessary for removing, stockpiling, sorting and installing the curb including, excavation, bedding (gravel and concrete) material, alignment controls, cutting and fitting, backfilling and other work required for or incidental to the completion of this item.
- c. This unit price shall be considered full compensation for installation of used curbing or installation of new curbing.

ITEM NO. 7-8-2-X: Sidewalk Replacement

1. Method of Measurement:

- a. This pay item shall be measured per linear foot, square foot, or square yard as shown in the Bid Schedule.
- b. Linear feet shall be measured along the length of sidewalk replacement or as designated on the Drawings, or as directed by the Engineer.
- c. Square feet shall be measured along the length of the sidewalk replacement multiplied by the approved width of the sidewalk replacement, or as directed by the Engineer.
- d. Square yards shall be measured along the length of the sidewalk replacement times the approved payment width as depicted on the Drawings.
- e. Note:
 - i. X = Type of Sidewalk
 1. Asphalt
 2. Concrete
 3. Brick

2. Basis of Payment:

- a. This unit price shall constitute full compensation for the furnishing of all materials labor, equipment, and tools necessary for sidewalk replacement including, excavation, bedding (gravel) materials, concrete, asphalt, brick, alignment controls, cutting and fitting, backfilling and other work required for or incidental to the completion of this item.

SUBSECTION NO. 7-9: REMOVAL AND ABANDONMENT

ITEM NO. 7-9-1-X: Removal of Existing Water Main

1. Method of Measurement:
 - a. This pay item shall be measured per linear foot or a lump sum basis, as shown in the Bid Schedule.
 - b. Measurement shall be taken along the centerline of the water main. This pay item shall include all water main, valves, and fittings along the water main that is to be removed.
 - c. Note:
 - i. X = Type of Water Main to be Removed
 1. Non-Asbestos Cement
 2. Asbestos Cement
2. Basis of Payment:
 - a. The unit price for this item shall constitute full compensation for all layout, saw cutting, labor, materials and equipment necessary to excavate the trench and remove the water main including valves and fittings, backfill and compact the trench, include restoration to subgrade, and properly dispose of the removed water main.

ITEM NO. 7-9-2-X: Abandonment of Existing Water Main

1. Method of Measurement:
 - a. This pay item shall be measured per linear foot, cubic yard, or a lump sum basis as shown in the Bid Schedule.
 - b. Linear feet shall be measured along the centerline of the water main.
 - c. Cubic yards shall be measured using the length of the water main multiplied by the cross-sectional area of the water main, or as directed by the Engineer.
 - d. Note:
 - i. X = Type of Abandonment
 1. Leave in Place
 2. Flowable Fill

2. Basis of Payment:

- a. The unit price for this item shall constitute full compensation for all layout, saw cutting, labor, materials and equipment necessary to excavate the trench and abandon the water main including valves and fittings, backfill and compact the trench, and include restoration to subgrade.

ITEM NO. 7-10: Night Work Premium

1. Method of Measurement:

- a. This item shall be paid for on an hourly basis per crew with time measured beginning after normal work hours and ending when the overnight effort is concluded the following day.
- b. This payment item shall include the extra charges associated with special equipment particular to nighttime construction, payroll premiums for overtime work by hourly employees and premium costs associated with obtaining asphalt and gravel outside of the supplier's normal production hours.
- c. For the purposes of this payment item, a crew will be defined as a foreman, two laborers/pipe fitters, excavator operator, loader operator or rubber tire backhoe operator, two dump trucker operators, and all associated equipment.

2. Basis of Payment:

- a. The quantities of equipment and labor associated with this work shall be compensated for in this payment item and shall not be compensated for under any other individual payment items for which they may otherwise be classified.

ITEM NO. 7-11-1: Casting Adjustment for Manholes

1. Method of Measurement:

- a. This item shall be measured on a unit basis as shown in the Bid Schedule with one unit being the adjustment of one casting.

2. Basis of Payment:

- a. The unit price for this item shall constitute full compensation for all labor, materials and equipment necessary to adjust the casting to be flush with the final finish surface.

SECTION NO. 8: INTERIOR PLUMBING

ITEM NO. 8-1: Plumbing Permit

1. Method of Measurement:

- a. This pay item shall be measured on a unit basis as shown in the Bid Schedule.

2. Basis of Payment:

- a. The unit price for this item shall constitute full compensation for the reimbursement of the application fee cost for the Plumbing Permit. The permit shall be filled out by the Contractor's licensed plumber.

ITEM NO. 8-2: Compression Fitting with a Plug

1. Method of Measurement:

- a. This pay item shall be measured on a unit basis as shown in the Bid Schedule.

2. Basis of Payment:

- a. The unit price for this item shall constitute full compensation for all labor, materials, and equipment necessary to furnish and install a compression fitting with a plug according to the Plumbing Code recognized by the Town or City where the project is located.

ITEM NO. 8-3: Reducer for Service Line to Copper Tubing

1. Method of Measurement:

- a. This pay item shall be measured on a unit basis as shown in the Bid Schedule.

2. Basis of Payment:

- a. The unit price for this item shall constitute full compensation for all labor, materials, and equipment necessary to furnish and install a reducer for the service line to copper tubing according to the Plumbing Code recognized by the Town or City where the project is located.

ITEM NO. 8-4: All Meter Fittings including Cellar Valve, Meter Horn, Radio Wire, and Residential Dual Check Valve

1. Method of Measurement:

- a. This pay item shall be measured on a unit basis as shown in the Bid Schedule.
- b. One unit shall include one Cellar Valve, one Meter Horn, one Radio Wire, and one Residential Dual Check Valve.

2. Basis of Payment:

- a. The unit price for this item shall constitute full compensation for all labor, materials, and equipment necessary to furnish and install the meter fittings listed above according to the Plumbing Code recognized by the Town or City where the project is located.

ITEM NO. 8-5: Pressure Reducing Valve

1. Method of Measurement:

- a. This pay item shall be measured on a unit basis as shown in the Bid Schedule.

2. Basis of Payment:

- a. The unit price for this item shall constitute full compensation for all labor, materials, and equipment necessary to furnish and install a pressure reducing valve according to the Plumbing Code recognized by the Town or City where the project is located.

ITEM NO. 8-6: Expansion Tank

1. Method of Measurement:

- a. This pay item shall be measured on a unit basis as shown in the Bid Schedule.

2. Basis of Payment:

- a. The unit price for this item shall constitute full compensation for all labor, materials, and equipment necessary to furnish and install an expansion tank according to the Plumbing Code recognized by the Town or City where the project is located.

ITEM NO. 8-7: Fitting to Connect Copper to Existing Interior Plumbing

1. Method of Measurement:

- a. This pay item shall be measured on a unit basis as shown in the Bid Schedule.

2. Basis of Payment:

- a. The unit price for this item shall constitute full compensation for all labor, materials, and equipment necessary to furnish and install a fitting that connects the new copper tubing to the existing interior plumbing according to the Plumbing Code recognized by the Town or City where the project is located.

ITEM NO. 8-8: Copper Tubing to Complete Connection to Existing Interior Plumbing (POTABLE WATER)

1. Method of Measurement:

- a. This pay item shall be measured on a linear foot basis as shown in the Bid Schedule.

2. Basis of Payment:

- a. The unit price for this item shall constitute full compensation for all labor, materials, and equipment necessary to furnish and install copper tubing to complete the connection from the new service line to the existing interior plumbing according to the Plumbing Code recognized by the Town or City where the project is located.
- b. This item shall also include all hangers and other accessories necessary to install the pipe per code.

ITEM NO. 8-9: Piping from Pressure Tank to Hose Bib or Irrigation System (NON-POTABLE WATER)

1. Method of Measurement:

- a. This pay item shall be measured on a linear foot basis as shown in the Bid Schedule.

2. Basis of Payment:

- a. The unit price for this item shall constitute full compensation for all labor, materials, and equipment necessary to furnish and install piping from the pressure tank to a hose bib or

irrigation system according to the Plumbing Code recognized by the Town or City where the project is located.

- b. This item shall also include all hangers and other accessories necessary to install the pipe per code.
- c. This item shall include an interior survey of all plumbing fixtures and appliances to verify that the non-potable water system is no longer connected to any of the interior plumbing fixtures and appliances.

ITEM NO. 8-10: Fittings for Piping from Pressure Tank to Hose Bib or Irrigation System (NON-POTABLE WATER)

1. Method of Measurement:

- a. This pay item shall be measured on a unit basis as shown in the Bid Schedule.

2. Basis of Payment:

- a. The unit price for this item shall constitute full compensation for all labor, materials, and equipment necessary to furnish and install fittings for the piping from the pressure tank to a hose bib or irrigation system according to the Plumbing Code recognized by the Town or City where the project is located.

ITEM NO. 8-11: New Ball Valve on Discharge Side of Pressure Tank (NON-POTABLE WATER)

1. Method of Measurement:

- a. This pay item shall be measured on a unit basis as shown in the Bid Schedule.

2. Basis of Payment:

- a. The unit price for this item shall constitute full compensation for all labor, materials, and equipment necessary to furnish and install a new ball valve on the discharge side of the pressure tank according to the Plumbing Code recognized by the Town or City where the project is located.

ITEM NO. 8-12: New Hose Bib with Connection to Pipe (NON-POTABLE WATER)

1. Method of Measurement:

- a. This pay item shall be measured on a unit basis as shown in the Bid Schedule.

2. Basis of Payment:

- a. The unit price for this item shall constitute full compensation for all labor, materials, and equipment necessary to furnish and install a new hose bib with a connection to interior plumbing for non-potable water according to the Plumbing Code recognized by the Town or City where the project is located.

ITEM NO. 8-13: New Pipe Connection to Existing Hose Bib (NON-POTABLE WATER)

1. Method of Measurement:

- a. This pay item shall be measured on a unit basis as shown in the Bid Schedule.

2. Basis of Payment:

- a. The unit price for this item shall constitute full compensation for all labor, materials, and equipment necessary to furnish and install a new pipe connection to an existing hose bib according to the Plumbing Code recognized by the Town or City where the project is located.

ITEM NO. 8-14: New Pipe Connection to Existing Irrigation System (NON-POTABLE WATER)

1. Method of Measurement:

- a. This pay item shall be measured on a unit basis as shown in the Bid Schedule.

2. Basis of Payment:

- a. The unit price for this item shall constitute full compensation for all labor, materials, and equipment necessary to furnish and install a new pipe connection to an existing irrigation system according to the Plumbing Code recognized by the Town or City where the project is located.

ITEM NO. 8-15: Labels at Tank and Hose Bib (NON-POTABLE WATER)

1. Method of Measurement:

- a. This pay item shall be measured on a unit basis as shown in the Bid Schedule.

2. Basis of Payment:

- a. The unit price for this item shall constitute full compensation for all labor, materials, and equipment necessary to furnish and install a new labels at the water tank and any hose bibs which utilize non-potable water according to the Plumbing Code recognized by the Town or City where the project is located.

ITEM NO. 8-16: Interior Modifications

1. Method of Measurement:

- a. This pay item shall be measured as an allowance as shown in the Bid Schedule.

2. Basis of Payment:

- a. The allowance for this item shall constitute full compensation for all labor, materials, and equipment necessary to restore the interior of a building to its original condition prior to construction. This pay item shall be used to cover all interior modification items affected by normal installation of interior plumbing. Items shall include, but are not limited to, the replacement of dry wall, ceiling restoration, interior paint, etc.
- b. The Contractor shall be responsible for coordinating with a subcontractor relative to the type of work to be performed and obtain a quote for any item which exceeds \$1,000.00 per address.
- c. This pay item shall only be used with approval from the Engineer or Owner.

APPENDIX A

Hydrant and Valve Opening Direction

System	Town	Open Direction
Amherst Village District	Amherst	Right
Bon Terrain	Amherst	Left
Souhegan Woods	Amherst	Left
Atkinson	Atkinson	Left
Locke Lake	Barnstead	Left
Bedford	Bedford	Right
Bow	Bow	Left
Chester	Chester	Left
Glenn Ridge	Derry	Left
Maple Hills	Derry	Left
Farmstead	Derry	Left
Derry	Derry	Right
Glenwoodlands	Epping	Right
Forest Ridge	Exeter	Left
Hollis	Hollis	Right
Hooksett	Hooksett	Left
Hudson	Hudson	Left
Thurston Woods	Lee	Left
Litchfield	Litchfield	Left

PENNICHUCK WATER WORKS

System	Town	Open Direction
Londonderry	Londonderry	Left
Springwood Hills	Londonderry	Right
Merrimack	Merrimack	Right
Sunrise Estates	Middleton	Left
Milford	Milford	Right
Nashua	Nashua	Right
Great Bay	Newmarket	Right
Birch Hill	North Conway	Left
Pelham	Pelham	Left
Pittsfield	Pittsfield	Left
Rolling Hills	Plaistow	Left
Sweet Hill	Plaistow	Right
Twin Ridge	Plaistow	Right
Raymond	Raymond	Left
Autumn Woods	Salem	Right
Salisbury	Salisbury	Left
Beaver Hollow	Sandown	Left
Tilton	Tilton	Left
Daniels Lake	Weare	Left
Windham	Windham	Left

APPENDIX B
Standard Details List

STANDARD DETAILS LIST

M= Mains, D= Domestic, F= Fire Service, L= Irrigation, T= Temporary, S= Special Detail

D01	Typical	1" - 1 1/4" Service & Valve Box Installation
D02	Typical	1 1/2" - 2" Service & Valve Box Installation
D03	Typical	Service Box in Paved Areas
D04	Typical	1" CT Service, 5/8", 3/4", 1" Meter Service
D05.1	Typical	1" HDPE Service, 5/8" Meter Service Through Floor
D05.2	Typical	1" HDPE Service, 5/8" Meter Service Through Wall
D06	Typical	1 1/4" Service, 5/8", 3/4", 1" Meter Service Through Floor
D07	Typical	1 1/4" Service, 5/8", 3/4", 1" Meter Service Through Wall
D08	Typical	1 1/2" Service, 5/8", 3/4", 1" Meter Service Through Floor
D09	Typical	1 1/2" Service, 5/8", 3/4", 1" Meter Service Through Wall
D10	Typical	2" Service, 5/8", 3/4", 1" Meter Service Through Floor
D11	Typical	2" Service 5/8", 3/4", 1" Meter Through Wall
D12	Typical	2" Service, with Back Flow W/ 5/8", 3/4", 1" Meter Service Through Floor
D13	Typical	2" Service, with Back Flow w/ 5/8", 3/4" or 1" Meter Service Through Wall
D14	Typical	Has been removed no longer needed
D15	Typical	Commercial Service Tapped Off Fire Service: 2" or Smaller
D16	Typical	Residential Service Tapped Off Fire Service: 1" to 2"
D17	Typical	Commercial Service Tapped Off Fire Service: 4" or Larger
D18	Typical	1 1/2" & 2" Positive Displ. Meter - Combined Fire & Domestic Service Entrance Detail
D19	Typical	2" TRU/FLO Compound Meter - Combined Fire & Domestic Service Entrance Detail
D20	Typical	3 Inch Meter
D21	Typical	4 Inch Meter
D22	Typical	Meter Pit: 18" Diameter Coil Type for 5/8" and 3/4" Meter
F01	Typical	Fire Service Connection: 4" or Larger Through Floor
F02	Typical	Fire Service Connection: 4" or Larger Through Wall
F03	Typical	Fire Service Connection: 1" CT
F04	Typical	Fire Service Connection: 1 1/2" and 2" HDPE Through Floor
F05	Typical	Fire Service Connection: 1 1/2" and 2" HDPE Through Wall
L01	Typical	Irrigation: 1" Setup Options
L02	Typical	Irrigation: Shallow 2" Meter Pit
L03	Typical	Irrigation: 1 1/2" Above Ground Meter Vault
L04	Typical	Irrigation: 2" Above Ground Meter Vault
M01	Typical	Utility Separation
M02	Typical	Trench
M03	Typical	1" Release Valve Installation on Ductile Iron
M04	Typical	2" Release Valve Installation on End of 2" Main
M05	Typical	2" Release Valve Installation on Ductile Iron
M06	Typical	1" Release Valve Installation on PVC
M07	Typical	2" Release Valve Installation on PVC
M08	Typical	Tee Installation
M09	Typical	Tee Installation on Existing Main
M10	Typical	Thrust Block Behind Fitting installation
M11	Typical	End of Main Installation with Gate Valve
M12	Typical	End of Main Installation without Gate Valve
M13	Typical	End of Main Installation with Reducer
M14	Typical	Valve Box
M15	Typical	Hydrant Installation
M16	Typical	Catch Basin Insulation
M17	Typical	Storm Drain / Water Main Parallel Runs - Elevation View
M18	Typical	Storm Drain / Water Main Intersecting Runs - Elevation View
M19	Typical	Insulation for Less Than 4'-0" of Cover
M20	Typical	Large Service and/or Tapping Sleeve

T01	<i>Typical</i>	Temporary Construction Meter	
T02	<i>Typical</i>	Temporary Main Fed from Hydrant	
T03	<i>Typical</i>	Temporary Fire Dept. Connection	
T04	<i>Typical</i>	Temporary Pedestrian/Roadway Crossing	
		Highlighted Items Revised in 2026	

APPENDIX C
Standard Details

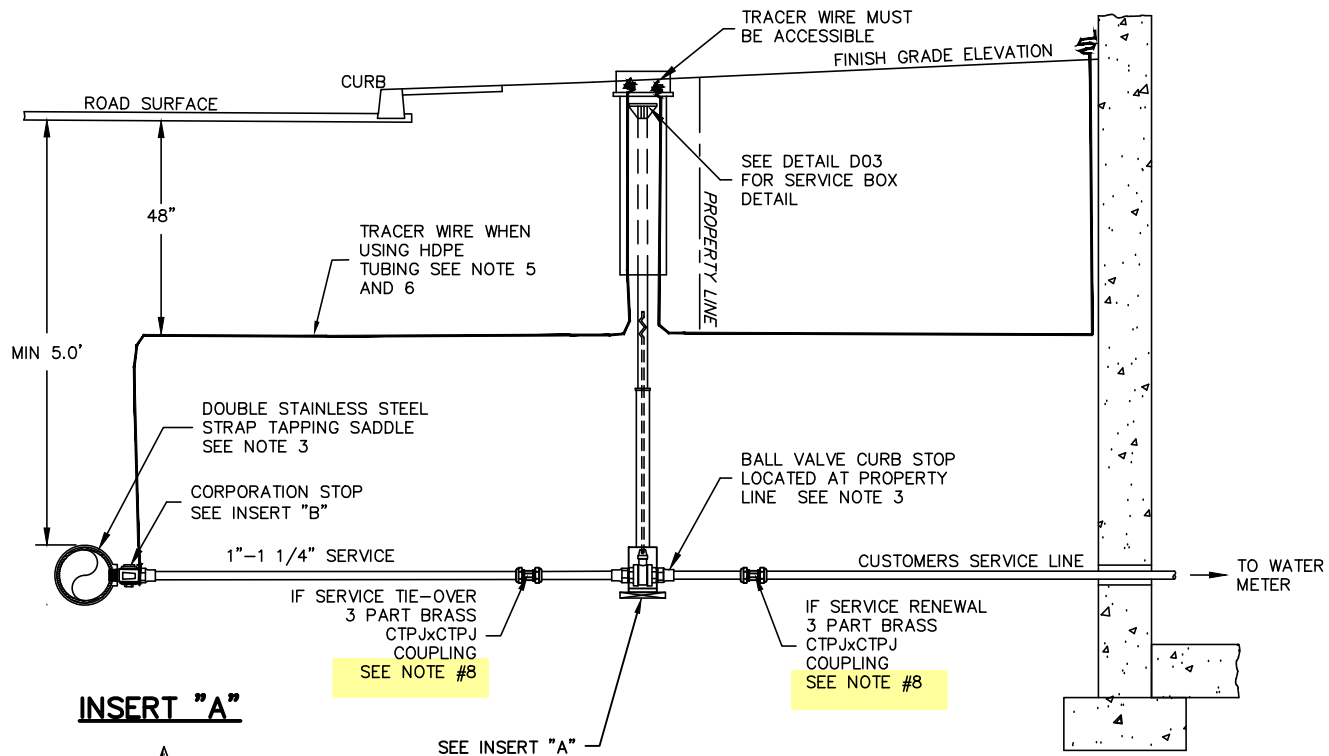

INSERT "A"

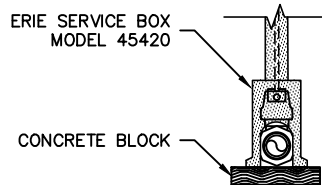

INSERT "B"

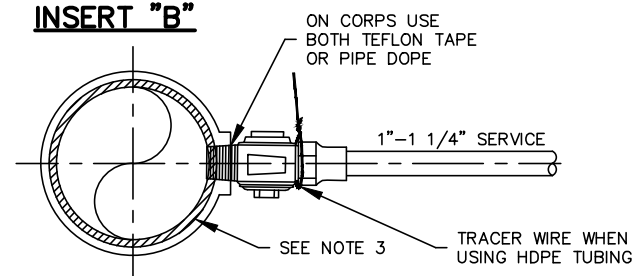

NOTES:

1. ALL MATERIALS AND INSTALLATION PROCEDURES WILL CONFORM TO P.W.W. TECHNICAL SPECIFICATIONS.
2. ALL PIPE SHOULD HAVE A MINIMUM DEPTH OF 5' FROM TOP OF PIPE TO FINISH GRADE.
3. IF WATER MAIN IS PVC OR TRANSITE, A DOUBLE STAINLESS STEEL STRAP TAPPING SADDLE MUST BE USED TO CONNECT THE CORPORATION TO THE WATER MAIN. CONFORM TO P.W.W. TECHNICAL SPECIFICATIONS.
4. IF TAPPING A FIRE SERVICE, THEN SEE DETAIL D15 AND D16.
5. USE 10-GAUGE SOLID-CORE COATED BLUE TRACER WIRE PER P.W.W. TECHNICAL SPECIFICATIONS. SPLICES REQUIRE SNAKEBITE LSC1030C LOCKING CONNECTORS OR EQUAL.
6. INSTALL 3" WIDE BLUE UNDERGROUND WARNING TAPE.
7. SERVICE TO BE PLACED ON 1' COMPACTED SAND BED AND COVERED IN 1' COMPACTED SAND BED.
8. ANY SECTION OF NEW SERVICE LINE THAT IS 60' OR LESS IN LENGTH, SHALL CONTAIN NO COUPLINGS, UNIONS OR FITTINGS.
9. A NEW SERVICE LINE SHALL BE INSTALLED NO CLOSER THAN 10' TO A SEPTIC TANK, LEACH BED OR SEWER LINE. THIS DISTANCE CAN BE REDUCED TO 5' IF THE SERVICE LINE IS SLEEVED INSIDE A GASKETED PIPE.
10. WHEN A NEW SERVICE LINE CROSSES BENEATH A DRIVEWAY, THE SERVICE LINE SHALL BE SLEEVED WITHIN A PIPE EQUIVALENT TO SDR 35 AND MINIMUM DIAMETER OF 3".

ITEM REVISED IN 2026

 **PENNICHUCK**
WATER

DETAIL D01
TYPICAL 1"-1 1/4" SERVICE &
VALVE BOX INSTALLATION DETAIL
PENNICHUCK WATER WORKS, INC.
REV: 02-20-2026 SCALE: NTS

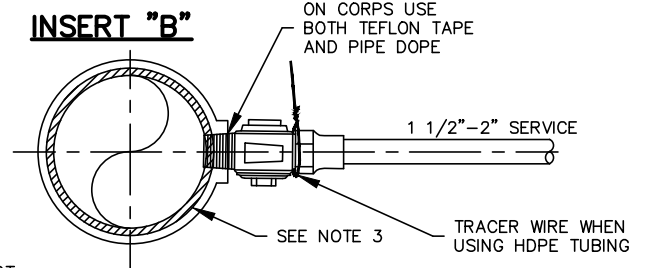
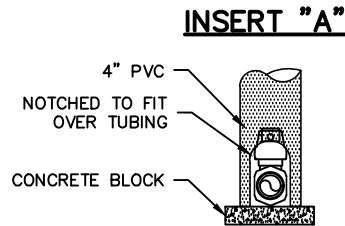
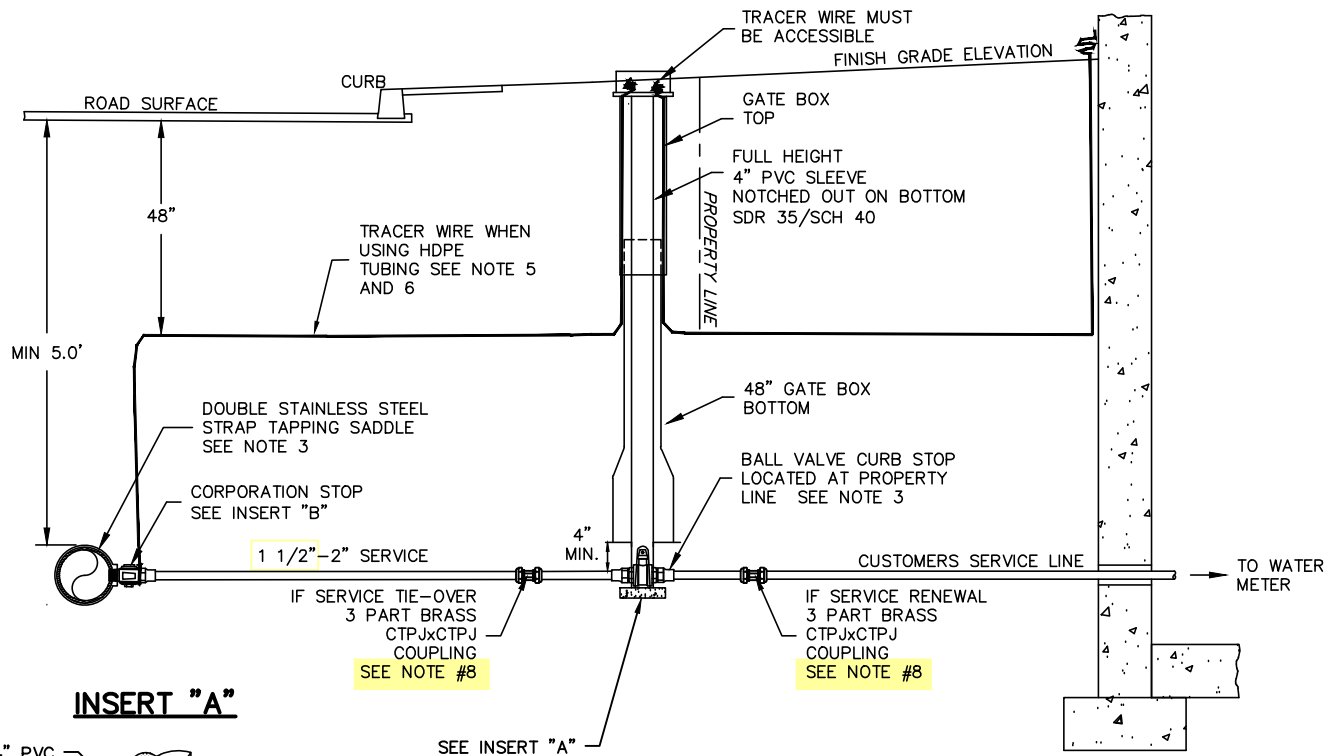

NOTES:

1. ALL MATERIALS AND INSTALLATION PROCEDURES WILL CONFORM TO P.W.W. TECHNICAL SPECIFICATIONS.
2. ALL PIPE SHOULD HAVE A MINIMUM DEPTH OF 5' FROM TOP OF PIPE TO FINISH GRADE.
3. IF WATER MAIN IS PVC OR TRANSITE, A DOUBLE STAINLESS STEEL STRAP TAPPING SADDLE MUST BE USED TO CONNECT THE CORPORATION TO THE WATER MAIN. CONFORM TO P.W.W. TECHNICAL SPECIFICATIONS.
4. IF TAPPING A FIRE SERVICE, THEN SEE DETAIL D15 AND D16.
5. USE 10-GAUGE SOLID-CORE COATED BLUE TRACER WIRE PER P.W.W. TECHNICAL SPECIFICATIONS. SPLICES REQUIRE SNAKEBITE LSC1030C LOCKING CONNECTORS OR EQUAL.
6. INSTALL 3" WIDE BLUE UNDERGROUND WARNING TAPE.
7. SERVICE TO BE PLACED ON 1' COMPACTED SAND BED AND COVERED IN 1' COMPACTED SAND BED.
8. ANY SECTION OF NEW SERVICE LINE THAT IS 60' OR LESS IN LENGTH, SHALL CONTAIN NO COUPLINGS, UNIONS OR FITTINGS.
9. A NEW SERVICE LINE SHALL BE INSTALLED NO CLOSER THAN 10' TO A SEPTIC TANK, LEACH BED OR SEWER LINE. THIS DISTANCE CAN BE REDUCED TO 5' IF THE SERVICE LINE IS SLEEVED INSIDE A GASKETED PIPE.
10. WHEN A NEW SERVICE LINE CROSSES BENEATH A DRIVEWAY, THE SERVICE LINE SHALL BE SLEEVED WITHIN A PIPE EQUIVALENT TO SDR 35 AND MINIMUM DIAMETER OF 3".

ITEM REVISED IN 2026



DETAIL D02
 TYPICAL 1 1/2"-2" SERVICE &
 VALVE BOX INSTALLATION DETAIL
 PENNICHUCK WATER WORKS, INC.
 REV: 02-20-2026 SCALE: NTS

ITEM REVISED IN 2023

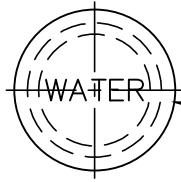

GATE BOX COVER
SEE DROP STYLE
COVER IN DETAIL M14

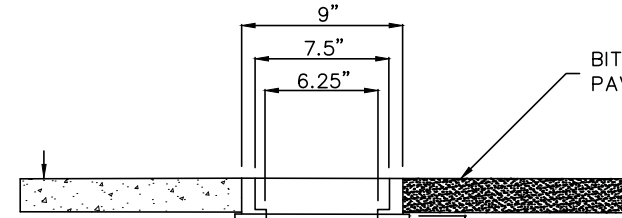

BITUMINOUS OR CONCRETE
PAVEMENT SURFACE (TYP)



EXISTING
GROUND

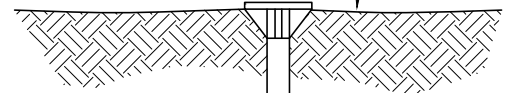

STANDARD GATE BOX
TOP WITH COVER
SEE TOP DETAIL IN
DETAIL M14

STANDARD SERVICE BOX
SEE P.W.W. TECHNICAL
SPECIFICATIONS

STANDARD SERVICE BOX
SEE P.W.W. TECHNICAL
SPECIFICATIONS

FOR 1½"–2" CURB STOPS: ELIMINATE
SERVICE BOX AND SPLIT IRON; ADD
48" GATE BOX BOTTOM AND FULL
HEIGHT 4" PVC SLEEVE
NOTCHED ON BOTTOM

SPLIT IRON IS 30" HIGH

½" STAINLESS STEEL
SPLIT IRON
FOR 1" TO 1¼"
CURB STOP

STANDARD FOOT PIECE
FOR 1" TO 1¼"
CURB STOPS

STANDARD FOOT PIECE
FOR 1" TO 1¼"
CURB STOPS

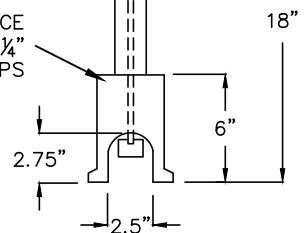
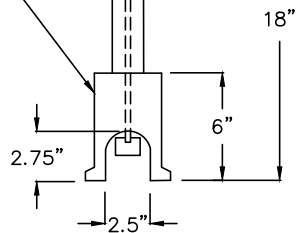

NOTE:
ALL MATERIALS AND INSTALLATION
PROCEDURES WILL CONFORM TO
P.W.W. TECHNICAL SPECIFICATIONS.



DETAIL D03
TYPICAL SERVICE BOX DETAIL
IN PAVED AREAS
PENNICHUCK WATER WORKS, INC.
REV: 03-15-2023 SCALE: NTS

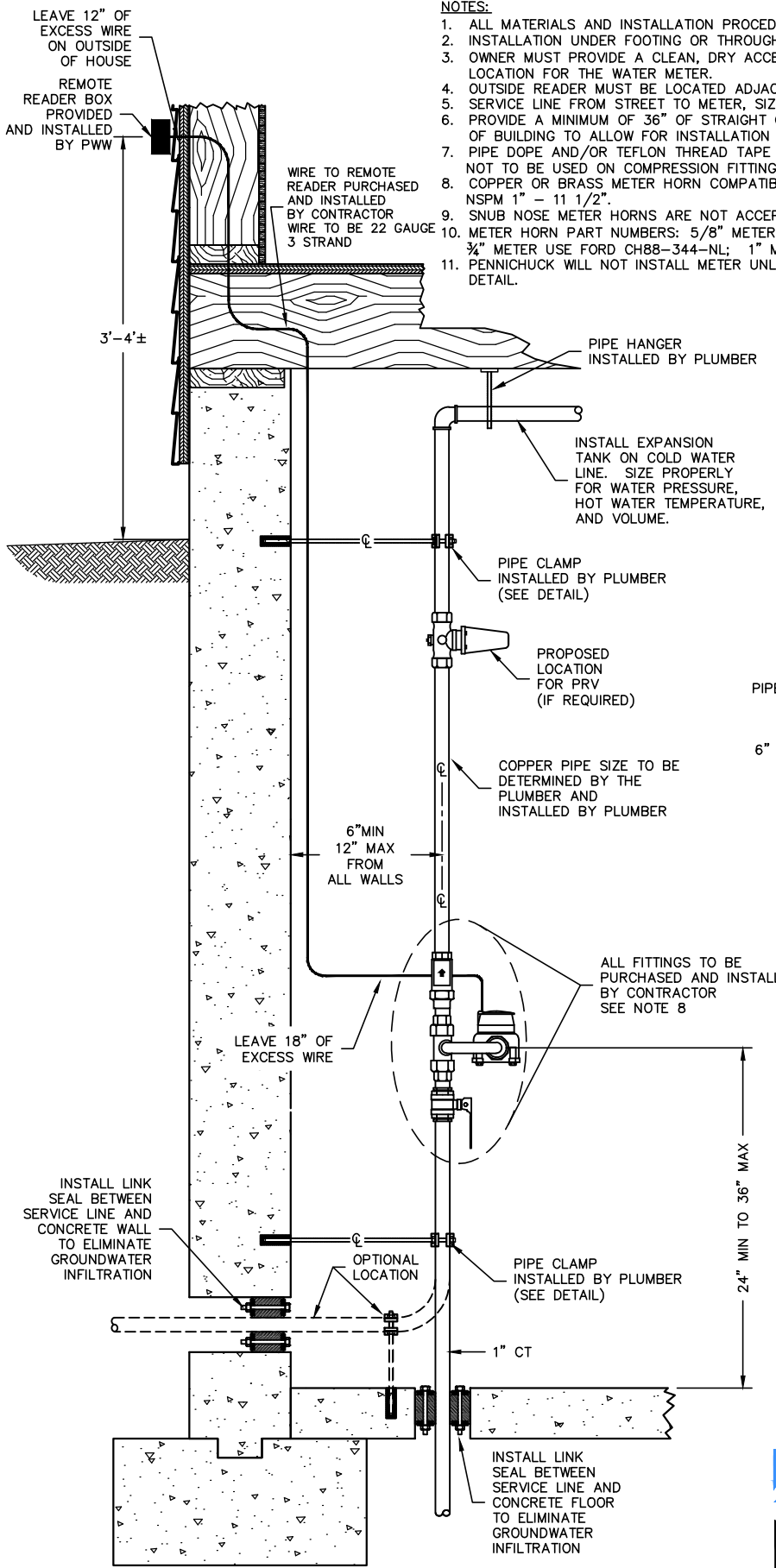

NOTES:

1. ALL MATERIALS AND INSTALLATION PROCEDURES WILL CONFORM TO P.W.W. SPECIFICATIONS.
2. INSTALLATION UNDER FOOTING OR THROUGH FOUNDATION WALL AT OWNER'S OPTION.
3. OWNER MUST PROVIDE A CLEAN, DRY ACCESSIBLE AND WARM (CONTINUALLY ABOVE 45°F) LOCATION FOR THE WATER METER.
4. OUTSIDE READER MUST BE LOCATED ADJACENT TO DRIVEWAY.
5. SERVICE LINE FROM STREET TO METER, SIZE & MATERIALS TO BE APPROVED BY P.W.W.
6. PROVIDE A MINIMUM OF 36" OF STRAIGHT COPPER TUBING AT SERVICE ENTRANCE INSIDE OF BUILDING TO ALLOW FOR INSTALLATION OF P.W.W. METER AND VALVES.
7. PIPE DOPE AND/OR TEFLON THREAD TAPE TO BE USED ON ALL FIP OR MIP FITTINGS. NOT TO BE USED ON COMPRESSION FITTING THREADS.
8. COPPER OR BRASS METER HORN COMPATIBLE WITH NEPTUNE T-10 METER WITH THREADS NSPM 1" - 1 1/2".
9. SNUB NOSE METER HORNS ARE NOT ACCEPTED.
10. METER HORN PART NUMBERS: 5/8" METER USE FORD KH-2-NL (3/4" X 5/8"); 3/4" METER USE FORD CH88-344-NL; 1" METER USE FORD CH88-444-NL.
11. PENNICHUCK WILL NOT INSTALL METER UNLESS ENTIRE INSTALLATION CONFORMS TO THIS DETAIL.

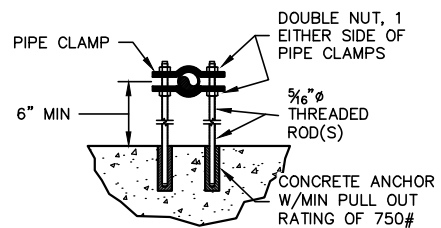

PIPE CLAMP (WALL)
NTS

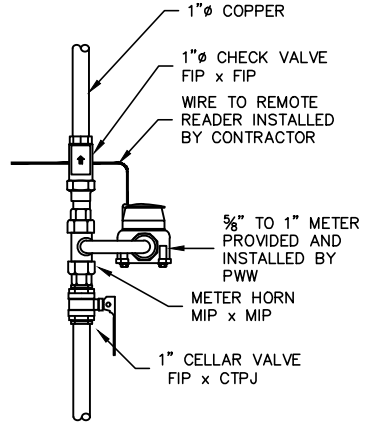

MAX. SPACING BETWEEN CELLAR VALVE, METER HORN AND CHECK VALVE TO NOT EXCEED 2 INCHES



DETAIL D04
TYPICAL 1" CT SERVICE WITH 5/8", 3/4", 1" METER SERVICE INSTALLATION
PENNICHUCK WATER WORKS, INC.
REV: 03-15-2023 SCALE: NTS

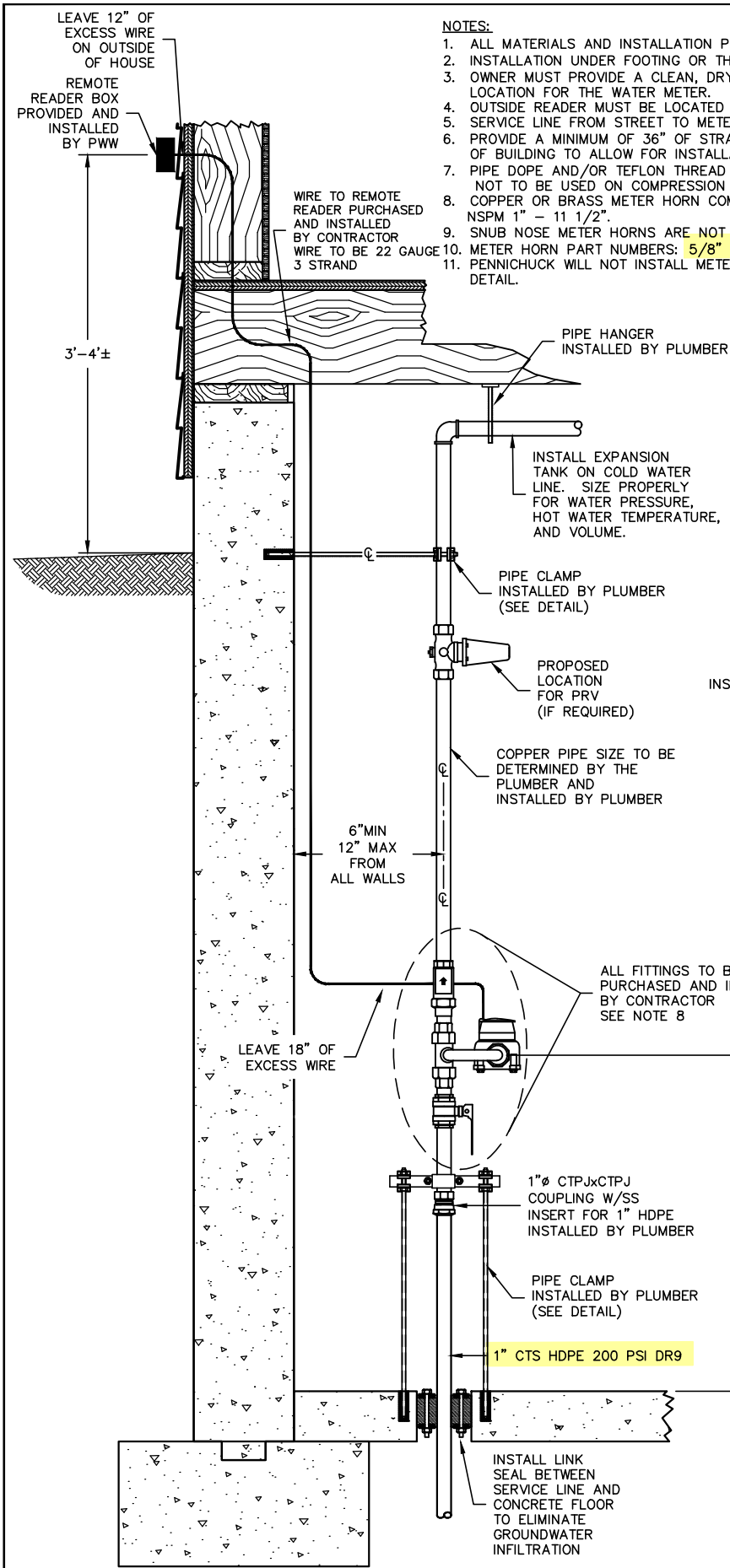

NOTES:

1. ALL MATERIALS AND INSTALLATION PROCEDURES WILL CONFORM TO P.W.W. SPECIFICATIONS.
2. INSTALLATION UNDER FOOTING OR THROUGH FOUNDATION WALL AT OWNER'S OPTION.
3. OWNER MUST PROVIDE A CLEAN, DRY ACCESSIBLE AND WARM (CONTINUALLY ABOVE 45°F) LOCATION FOR THE WATER METER.
4. OUTSIDE READER MUST BE LOCATED ADJACENT TO DRIVEWAY.
5. SERVICE LINE FROM STREET TO METER, SIZE & MATERIALS TO BE APPROVED BY P.W.W.
6. PROVIDE A MINIMUM OF 36" OF STRAIGHT COPPER TUBING AT SERVICE ENTRANCE INSIDE OF BUILDING TO ALLOW FOR INSTALLATION OF P.W.W. METER AND VALVES.
7. PIPE DOPE AND/OR TEFLON THREAD TAPE TO BE USED ON ALL FIP OR MIP FITTINGS. NOT TO BE USED ON COMPRESSION FITTING THREADS.
8. COPPER OR BRASS METER HORN COMPATIBLE WITH NEPTUNE T-10 METER WITH THREADS NSPM 1" - 1 1/2".
9. SNUB NOSE METER HORNS ARE NOT ACCEPTED.
10. METER HORN PART NUMBERS: 5/8" METER USE FORD KH-2-NL (3/4" X 5/8").
11. PENNICHUCK WILL NOT INSTALL METER UNLESS ENTIRE INSTALLATION CONFORMS TO THIS DETAIL.

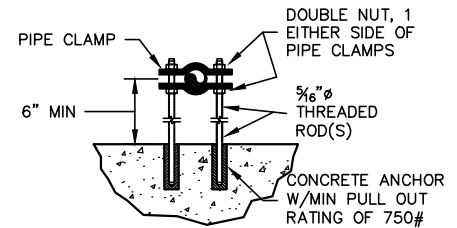

PIPE CLAMP (WALL)

NTS

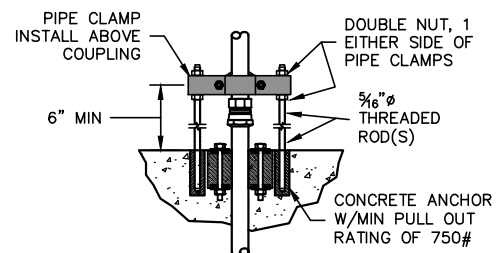

PIPE CLAMP (FLOOR)

NTS

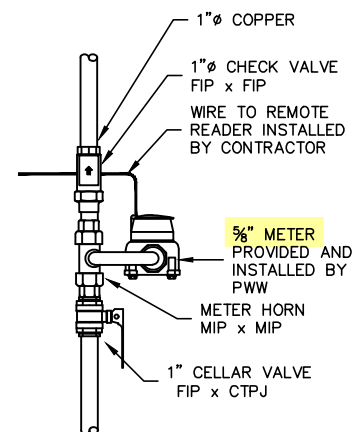

MAX. SPACING BETWEEN CELLAR VALVE, METER HORN AND CHECK VALVE TO NOT EXCEED 2 INCHES

ITEM REVISED IN 2026



DETAIL D05.1

1" HDPE SERVICE WITH 5/8" METER SERVICE INSTALLATION THROUGH FLOOR
 PENNICHUCK WATER WORKS, INC.
 REV: 02-20-2026 SCALE: NTS

1" DIAMETER POLYETHYLENE TUBING CAN ONLY BE USED WITH PRIOR WRITTEN APPROVAL FROM THE PENNICHUCK ENGINEERING DEPARTMENT

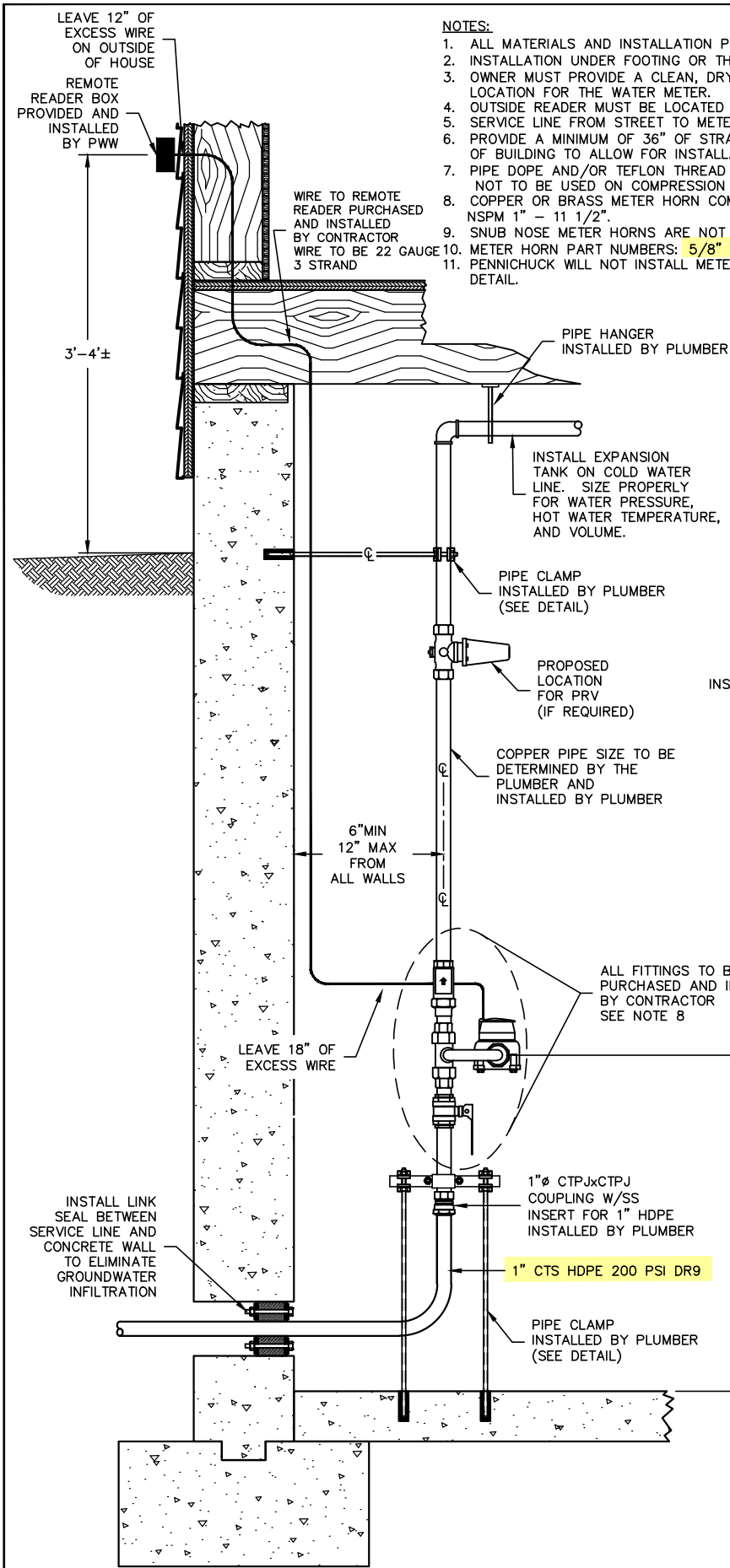

NOTES:

1. ALL MATERIALS AND INSTALLATION PROCEDURES WILL CONFORM TO P.W.W. SPECIFICATIONS.
2. INSTALLATION UNDER FOOTING OR THROUGH FOUNDATION WALL AT OWNER'S OPTION.
3. OWNER MUST PROVIDE A CLEAN, DRY ACCESSIBLE AND WARM (CONTINUALLY ABOVE 45°F) LOCATION FOR THE WATER METER.
4. OUTSIDE READER MUST BE LOCATED ADJACENT TO DRIVEWAY.
5. SERVICE LINE FROM STREET TO METER, SIZE & MATERIALS TO BE APPROVED BY P.W.W.
6. PROVIDE A MINIMUM OF 36" OF STRAIGHT COPPER TUBING AT SERVICE ENTRANCE INSIDE OF BUILDING TO ALLOW FOR INSTALLATION OF P.W.W. METER AND VALVES.
7. PIPE DOPE AND/OR TEFLON THREAD TAPE TO BE USED ON ALL FIP OR MIP FITTINGS. NOT TO BE USED ON COMPRESSION FITTING THREADS.
8. COPPER OR BRASS METER HORN COMPATIBLE WITH NEPTUNE T-10 METER WITH THREADS NSPM 1" - 11 1/2".
9. SNUB NOSE METER HORNS ARE NOT ACCEPTED.
10. METER HORN PART NUMBERS: 5/8" METER USE FORD KH-2-NL (3/4" X 5/8").
11. PENNICHUCK WILL NOT INSTALL METER UNLESS ENTIRE INSTALLATION CONFORMS TO THIS DETAIL.

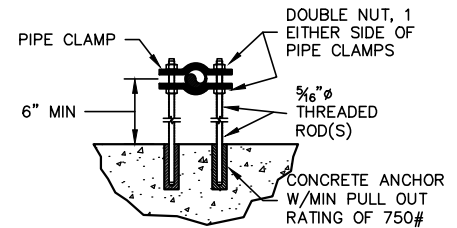

PIPE CLAMP (WALL)

NTS

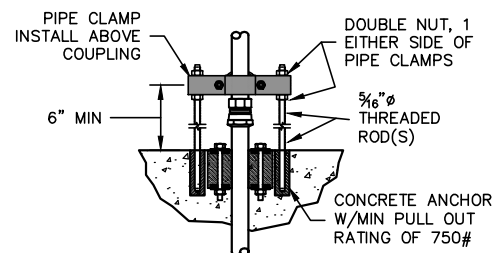

PIPE CLAMP (FLOOR)

NTS

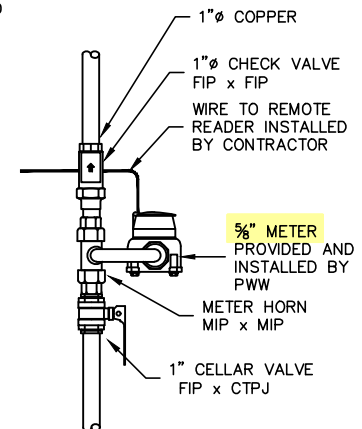

MAX. SPACING BETWEEN CELLAR VALVE, METER HORN AND CHECK VALVE TO NOT EXCEED 2 INCHES

ITEM REVISED IN 2026



DETAIL D05.2

1" HDPE SERVICE WITH 5/8" METER SERVICE INSTALLATION THROUGH WALL

PENNICHUCK WATER WORKS, INC.

REV: 02-20-2026 SCALE: NTS

1" DIAMETER POLYETHYLENE TUBING CAN ONLY BE USED WITH PRIOR WRITTEN APPROVAL FROM THE PENNICHUCK ENGINEERING DEPARTMENT

LEAVE 12" OF EXCESS WIRE ON OUTSIDE OF HOUSE

REMOTE READER BOX PROVIDED AND INSTALLED BY PWW

WIRE TO REMOTE READER PURCHASED AND INSTALLED BY CONTRACTOR WIRE TO BE 22 GAUGE 3 STRAND

3'-4"±

PIPE HANGER INSTALLED BY PLUMBER

INSTALL EXPANSION TANK ON COLD WATER LINE. SIZE PROPERLY FOR WATER PRESSURE, HOT WATER TEMPERATURE, AND VOLUME.

PIPE CLAMP INSTALLED BY PLUMBER (SEE DETAIL)

PROPOSED LOCATION FOR PRV (IF REQUIRED)

1"Ø COPPER PIPE TYPE K INSTALLED BY PLUMBER

6" MIN 12" MAX FROM ALL WALLS

ALL FITTINGS TO BE PURCHASED AND INSTALLED BY CONTRACTOR SEE NOTE 8

LEAVE 18" OF EXCESS WIRE

1" MIP x CTPJ INSTALLED BY PLUMBER

1½" CTPJ x 1½" FIP W/ 1½" x 1" BRASS BUSHING INSTALLED BY PLUMBER

1 1/4" HDPE PJ x FIP W/SS INSERT INSTALLED BY PLUMBER

1 1/4" CTS HDPE 200 PSI DR9

PIPE CLAMP INSTALLED BY PLUMBER (SEE DETAIL)

INSTALL LINK SEAL BETWEEN SERVICE LINE AND CONCRETE FLOOR TO ELIMINATE GROUNDWATER INFILTRATION

NOTES:

1. ALL MATERIALS AND INSTALLATION PROCEDURES WILL CONFORM TO P.W.W. SPECIFICATIONS.
2. INSTALLATION UNDER FOOTING OR THROUGH FOUNDATION WALL AT OWNER'S OPTION.
3. OWNER MUST PROVIDE A CLEAN, DRY ACCESSIBLE AND WARM (CONTINUALLY ABOVE 45°F) LOCATION FOR THE WATER METER.
4. OUTSIDE READER MUST BE LOCATED ADJACENT TO DRIVEWAY.
5. SERVICE LINE FROM STREET TO METER, SIZE & MATERIALS TO BE APPROVED BY P.W.W.
6. PROVIDE A MINIMUM OF 36" OF STRAIGHT COPPER TUBING AT SERVICE ENTRANCE INSIDE OF BUILDING TO ALLOW FOR INSTALLATION OF P.W.W. METER AND VALVES.
7. PIPE DOPE AND/OR TEFLON THREAD TAPE TO BE USED ON ALL FIP OR MIP FITTINGS. NOT TO BE USED ON COMPRESSION FITTING THREADS.
8. COPPER OR BRASS METER HORN COMPATIBLE WITH NEPTUNE T-10 METER WITH THREADS NSPM 1" - 11 1/2".
9. SNUB NOSE METER HORNS ARE NOT ACCEPTED.
10. METER HORN PART NUMBERS: 5/8" METER USE FORD KH-2-NL (¾" x 5/8"); ¾" METER USE FORD CH88-344-NL; 1" METER USE FORD CH88-444-NL.
11. PENNICHUCK WILL NOT INSTALL METER UNLESS ENTIRE INSTALLATION CONFORMS TO THIS DETAIL.

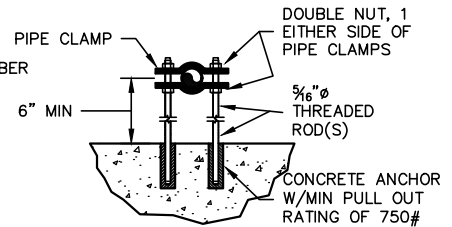

PIPE CLAMP (WALL)

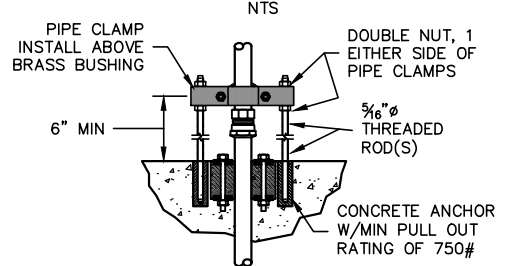

PIPE CLAMP (FLOOR)

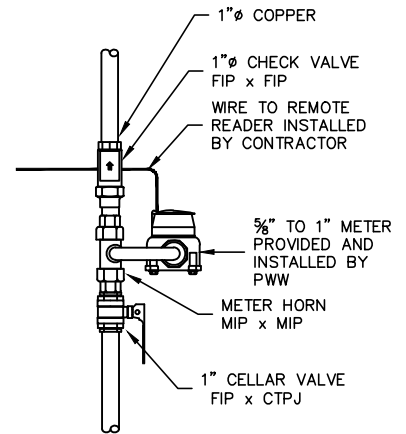

MAX. SPACING BETWEEN CELLAR VALVE, METER HORN AND CHECK VALVE TO NOT EXCEED 2 INCHES

ITEM REVISED IN 2026



DETAIL D06

TYPICAL 1½" SERVICE WITH 5/8", ¾" & 1" METER SERVICE THROUGH FLOOR INSTALLATION
 PENNICHUCK WATER WORKS, INC.
 REV: 02-20-2026 SCALE: NTS

NOTES:

1. ALL MATERIALS AND INSTALLATION PROCEDURES WILL CONFORM TO P.W.W. SPECIFICATIONS.
2. INSTALLATION UNDER FOOTING OR THROUGH FOUNDATION WALL AT OWNER'S OPTION.
3. OWNER MUST PROVIDE A CLEAN, DRY ACCESSIBLE AND WARM (CONTINUALLY ABOVE 45°F) LOCATION FOR THE WATER METER.
4. OUTSIDE READER MUST BE LOCATED ADJACENT TO DRIVEWAY.
5. SERVICE LINE FROM STREET TO METER, SIZE & MATERIALS TO BE APPROVED BY P.W.W.
6. PROVIDE A MINIMUM OF 36" OF STRAIGHT COPPER TUBING AT SERVICE ENTRANCE INSIDE OF BUILDING TO ALLOW FOR INSTALLATION OF P.W.W. METER AND VALVES.
7. PIPE DOPE AND/OR TEFLON THREAD TAPE TO BE USED ON ALL FIP OR MIP FITTINGS. NOT TO BE USED ON COMPRESSION FITTING THREADS.
8. COPPER OR BRASS METER HORN COMPATIBLE WITH NEPTUNE T-10 METER WITH THREADS NSPM 1" - 1 1/2".
9. SNUB NOSE METER HORNS ARE NOT ACCEPTED.
10. METER HORN PART NUMBERS: 5/8" METER USE FORD KH-2-NL (3/4" x 5/8"); 3/4" METER USE FORD CH88-344-NL; 1" METER USE FORD CH88-444-NL.
11. PENNICHUCK WILL NOT INSTALL METER UNLESS ENTIRE INSTALLATION CONFORMS TO THIS DETAIL.

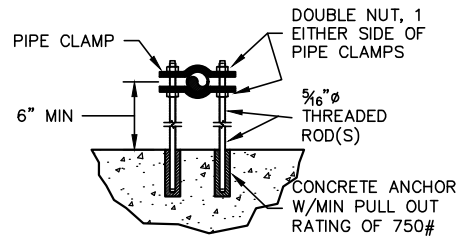
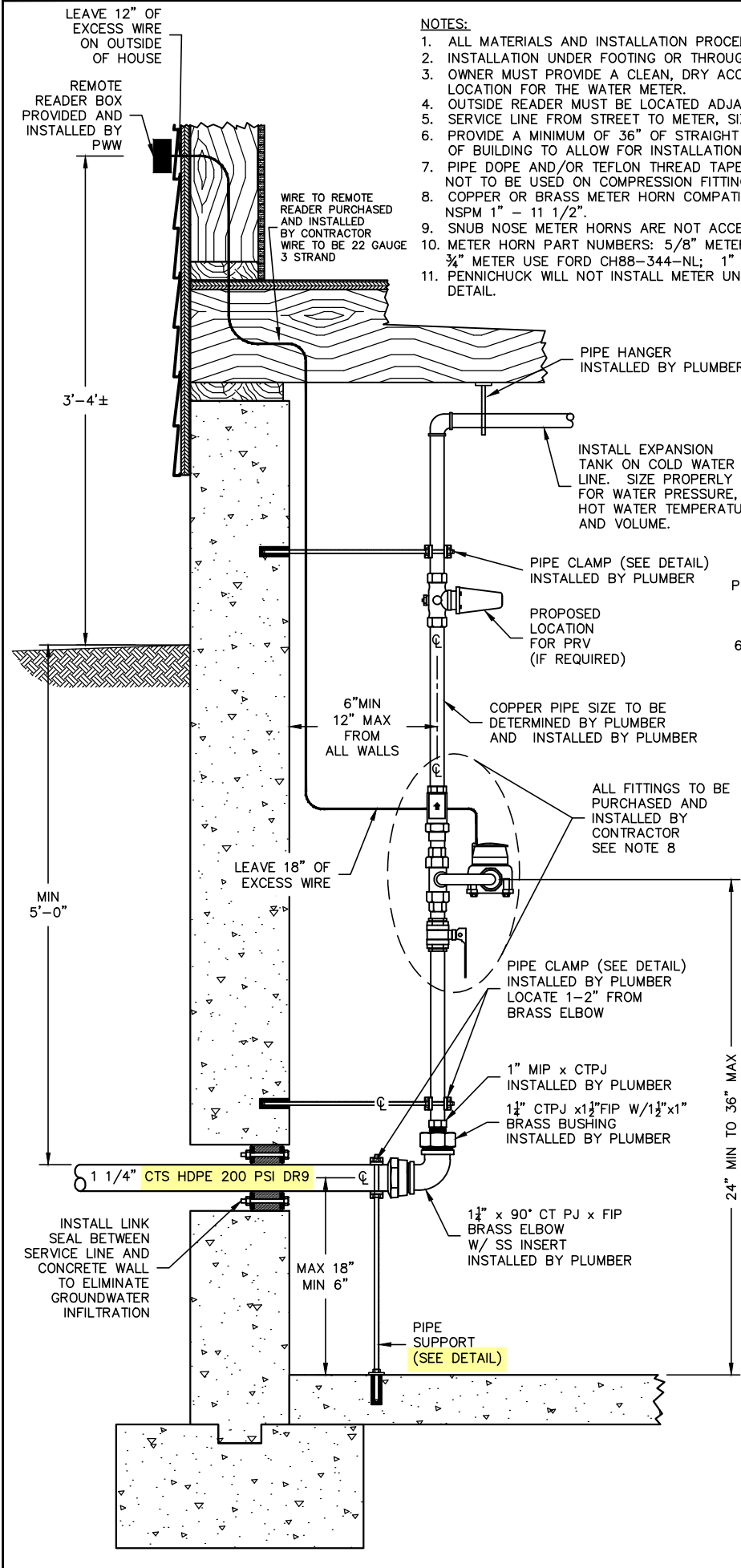

PIPE CLAMP
NTS

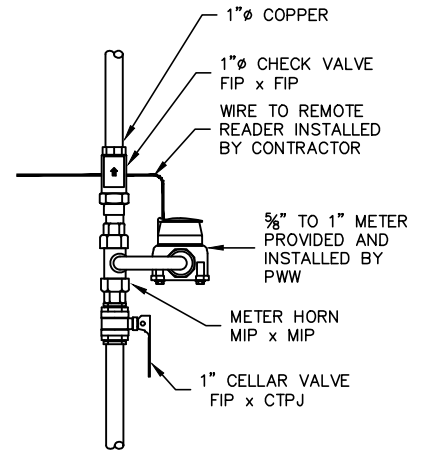

MAX. SPACING BETWEEN CELLAR VALVE, METER HORN AND CHECK VALVE TO NOT EXCEED 2 INCHES

ITEM REVISED IN 2026



DETAIL D07
TYPICAL 1 1/4" SERVICE WITH 5/8", 3/4" & 1" METER THROUGH WALL
INSTALLATION
PENNICHUCK WATER WORKS, INC.
REV: 02-20-2026 SCALE: NTS

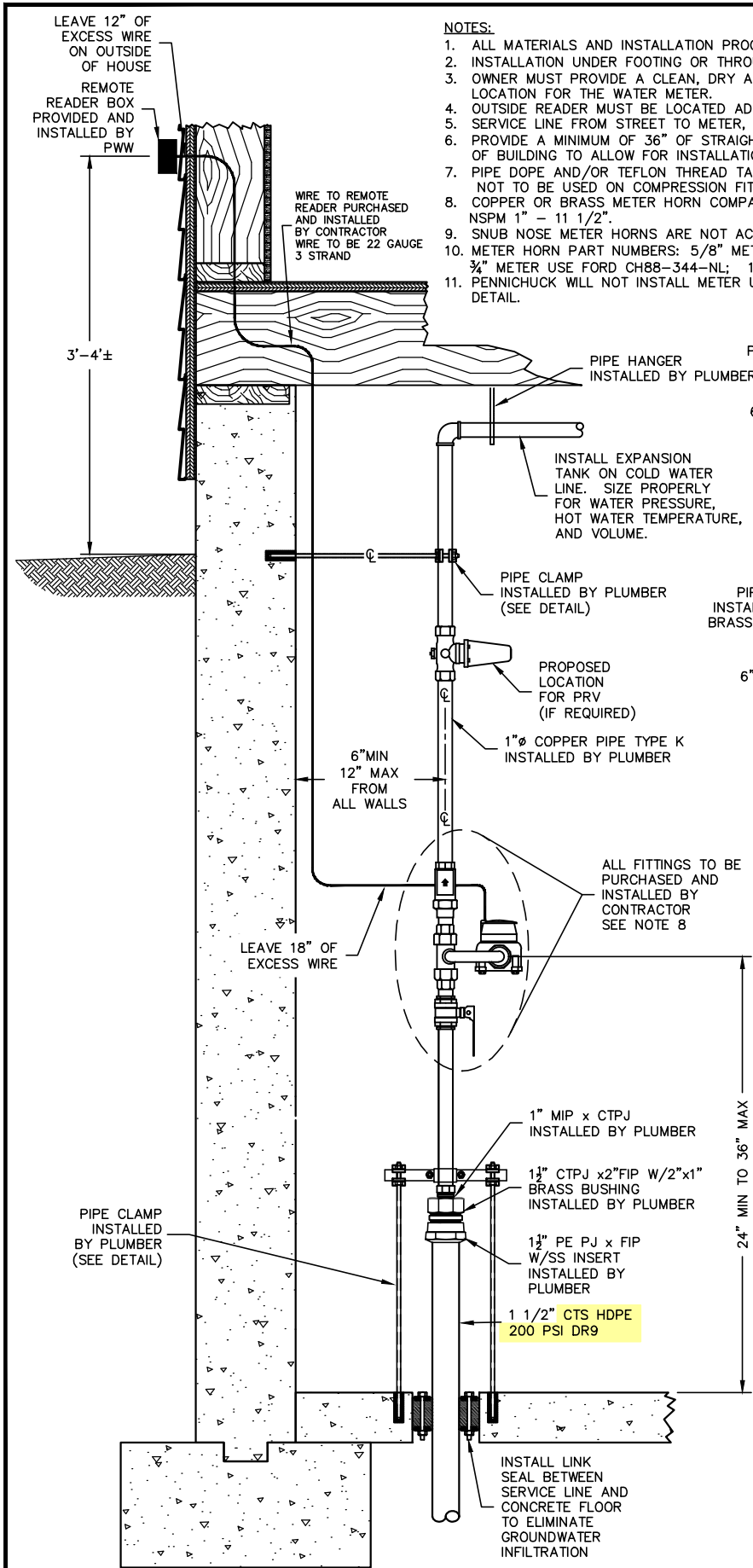

NOTES:

1. ALL MATERIALS AND INSTALLATION PROCEDURES WILL CONFORM TO P.W.W. SPECIFICATIONS.
2. INSTALLATION UNDER FOOTING OR THROUGH FOUNDATION WALL AT OWNER'S OPTION.
3. OWNER MUST PROVIDE A CLEAN, DRY ACCESSIBLE AND WARM (CONTINUALLY ABOVE 45°F) LOCATION FOR THE WATER METER.
4. OUTSIDE READER MUST BE LOCATED ADJACENT TO DRIVEWAY.
5. SERVICE LINE FROM STREET TO METER, SIZE & MATERIALS TO BE APPROVED BY P.W.W.
6. PROVIDE A MINIMUM OF 36" OF STRAIGHT COPPER TUBING AT SERVICE ENTRANCE INSIDE OF BUILDING TO ALLOW FOR INSTALLATION OF P.W.W. METER AND VALVES.
7. PIPE DOPE AND/OR TEFLON THREAD TAPE TO BE USED ON ALL FIP OR MIP FITTINGS. NOT TO BE USED ON COMPRESSION FITTING THREADS.
8. COPPER OR BRASS METER HORN COMPATIBLE WITH NEPTUNE T-10 METER WITH THREADS NSPM 1" - 11 1/2".
9. SNUB NOSE METER HORNS ARE NOT ACCEPTED.
10. METER HORN PART NUMBERS: 5/8" METER USE FORD KH-2-NL (3/4" X 5/8"); 3/4" METER USE FORD CH88-344-NL; 1" METER USE FORD CH88-444-NL.
11. PENNICHUCK WILL NOT INSTALL METER UNLESS ENTIRE INSTALLATION CONFORMS TO THIS DETAIL.

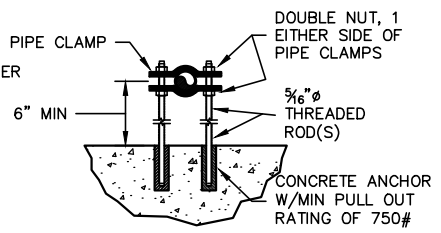

PIPE CLAMP (WALL)

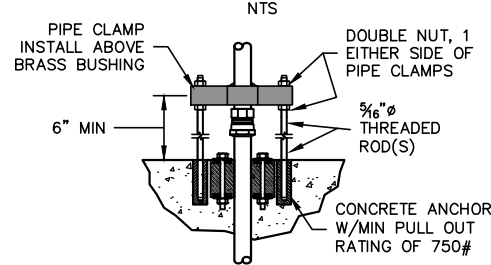

PIPE CLAMP (FLOOR)

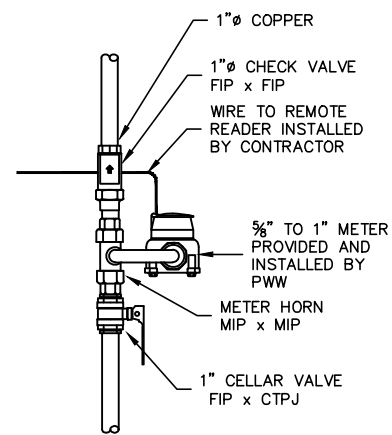

MAX. SPACING BETWEEN CELLAR VALVE, METER HORN AND CHECK VALVE TO NOT EXCEED 2 INCHES

ITEM REVISED IN 2026

DETAIL D08
 TYPICAL 1 1/2" SERVICE WITH 5/8", 3/4" & 1" METER SERVICE THROUGH FLOOR INSTALLATION
 PENNICHUCK WATER WORKS, INC.
 REV: 02-20-2026 SCALE: NTS

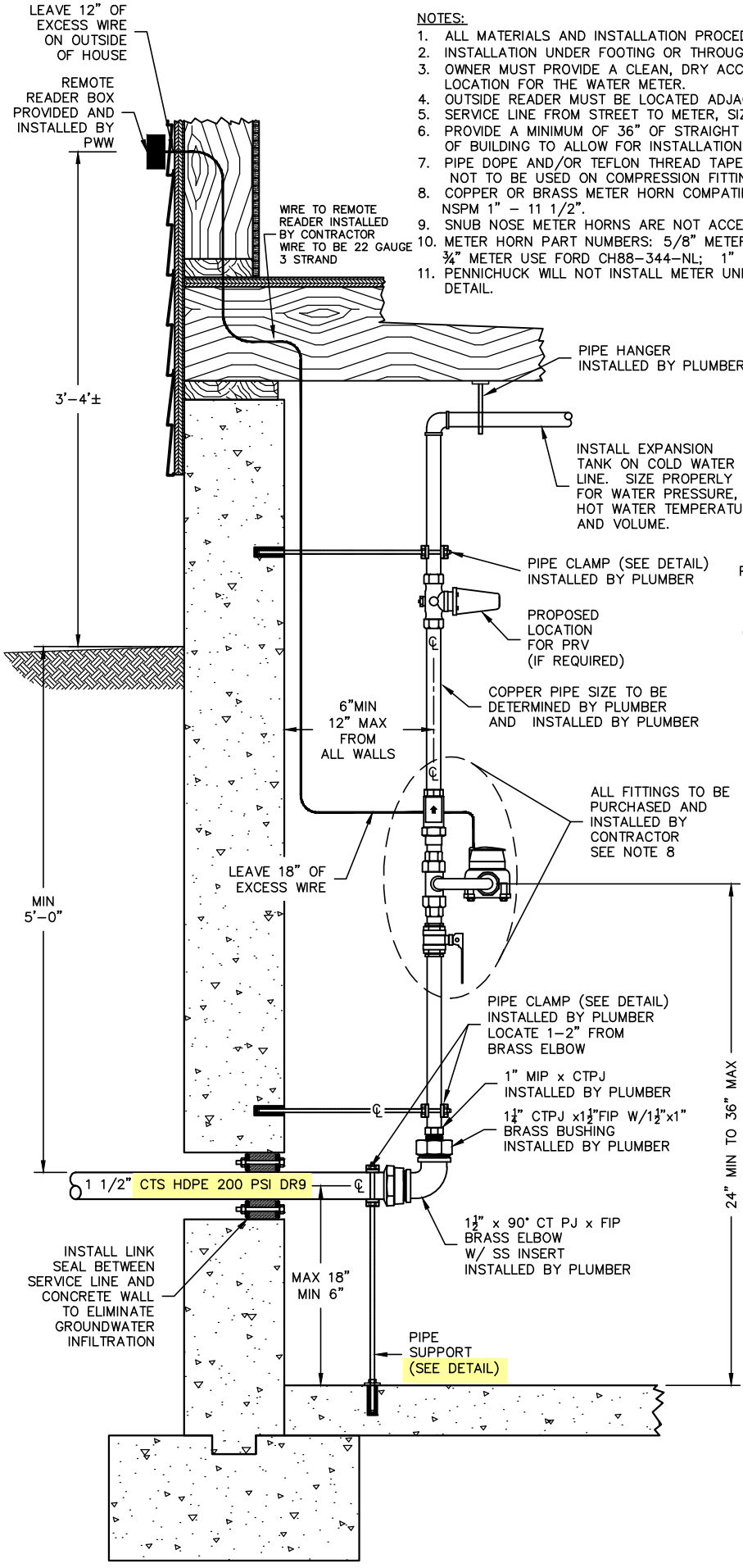

NOTES:

1. ALL MATERIALS AND INSTALLATION PROCEDURES WILL CONFORM TO P.W.W. SPECIFICATIONS.
2. INSTALLATION UNDER FOOTING OR THROUGH FOUNDATION WALL AT OWNER'S OPTION.
3. OWNER MUST PROVIDE A CLEAN, DRY ACCESSIBLE AND WARM (CONTINUALLY ABOVE 45°F) LOCATION FOR THE WATER METER.
4. OUTSIDE READER MUST BE LOCATED ADJACENT TO DRIVEWAY.
5. SERVICE LINE FROM STREET TO METER, SIZE & MATERIALS TO BE APPROVED BY P.W.W.
6. PROVIDE A MINIMUM OF 36" OF STRAIGHT COPPER TUBING AT SERVICE ENTRANCE INSIDE OF BUILDING TO ALLOW FOR INSTALLATION OF P.W.W. METER AND VALVES.
7. PIPE DOPE AND/OR TEFLON THREAD TAPE TO BE USED ON ALL FIP OR MIP FITTINGS. NOT TO BE USED ON COMPRESSION FITTING THREADS.
8. COPPER OR BRASS METER HORN COMPATIBLE WITH NEPTUNE T-10 METER WITH THREADS NSPM 1" - 1 1/2".
9. SNUB NOSE METER HORNS ARE NOT ACCEPTED.
10. METER HORN PART NUMBERS: 5/8" METER USE FORD KH-2-NL (3/4" X 5/8"); 3/4" METER USE FORD CH88-344-NL; 1" METER USE FORD CH88-444-NL.
11. PENNICHUCK WILL NOT INSTALL METER UNLESS ENTIRE INSTALLATION CONFORMS TO THIS DETAIL.

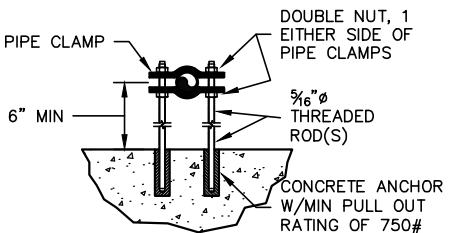

PIPE CLAMP
NTS

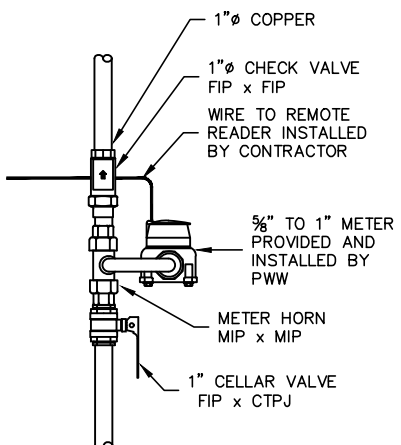

MAX. SPACING BETWEEN CELLAR VALVE, METER HORN AND CHECK VALVE TO NOT EXCEED 2 INCHES

ITEM REVISED IN 2026



DETAIL D09
TYPICAL 1 1/2" SERVICE WITH 5/8", 3/4" & 1" METER THROUGH WALL INSTALLATION
PENNICHUCK WATER WORKS, INC.
REV: 02-20-2026 SCALE: NTS

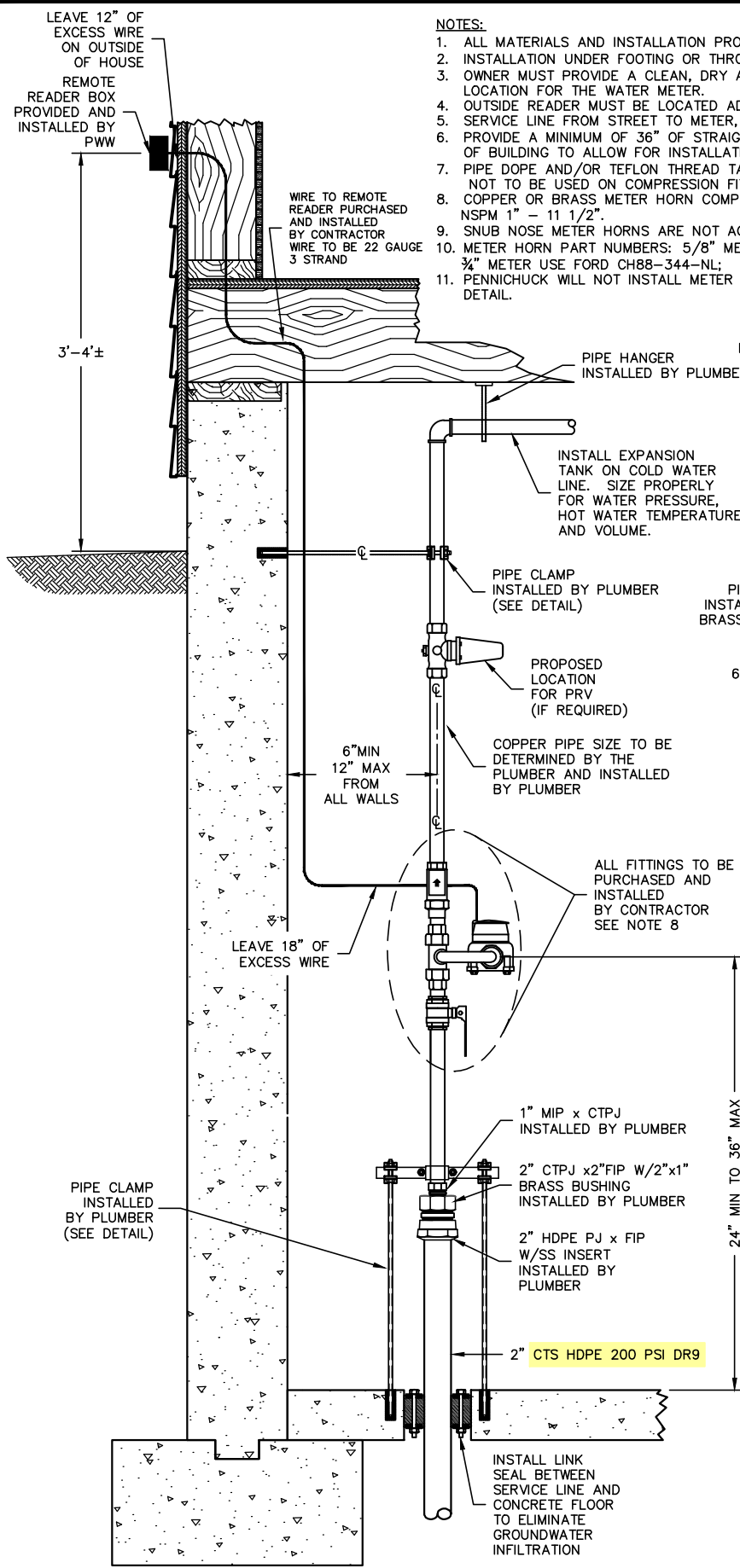

NOTES:

1. ALL MATERIALS AND INSTALLATION PROCEDURES WILL CONFORM TO P.W.W. SPECIFICATIONS.
2. INSTALLATION UNDER FOOTING OR THROUGH FOUNDATION WALL AT OWNER'S OPTION.
3. OWNER MUST PROVIDE A CLEAN, DRY ACCESSIBLE AND WARM (CONTINUALLY ABOVE 45°F) LOCATION FOR THE WATER METER.
4. OUTSIDE READER MUST BE LOCATED ADJACENT TO DRIVEWAY.
5. SERVICE LINE FROM STREET TO METER, SIZE & MATERIALS TO BE APPROVED BY P.W.W.
6. PROVIDE A MINIMUM OF 36" OF STRAIGHT COPPER TUBING AT SERVICE ENTRANCE INSIDE OF BUILDING TO ALLOW FOR INSTALLATION OF P.W.W. METER AND VALVES.
7. PIPE DOPE AND/OR TEFLON THREAD TAPE TO BE USED ON ALL FIP OR MIP FITTINGS. NOT TO BE USED ON COMPRESSION FITTING THREADS.
8. COPPER OR BRASS METER HORN COMPATIBLE WITH NEPTUNE T-10 METER WITH THREADS NSPM 1" - 1 1/2".
9. SNUB NOSE METER HORNS ARE NOT ACCEPTED.
10. METER HORN PART NUMBERS: 5/8" METER USE FORD KH-2-NL (3/4" X 5/8"); 3/4" METER USE FORD CH88-344-NL; 1" METER USE FORD CH88-444-NL.
11. PENNICHUCK WILL NOT INSTALL METER UNLESS ENTIRE INSTALLATION CONFORMS TO THIS DETAIL.

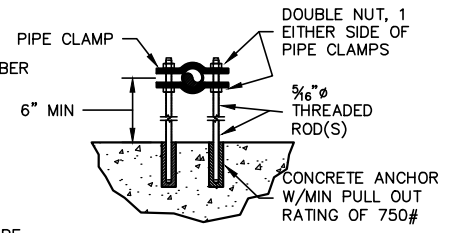

PIPE CLAMP (WALL)

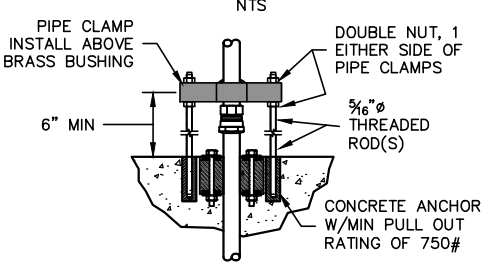

PIPE CLAMP (FLOOR)

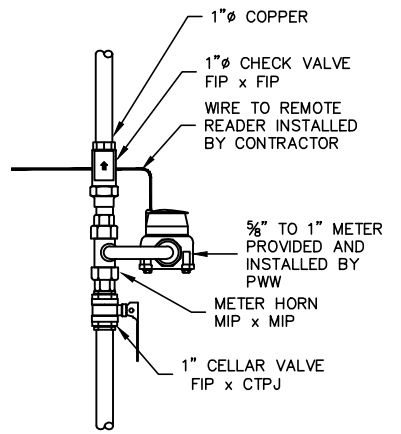

MAX. SPACING BETWEEN CELLAR VALVE, METER HORN AND CHECK VALVE TO NOT EXCEED 2 INCHES

ITEM REVISED IN 2026

DETAIL D10
 TYPICAL 2" SERVICE WITH 5/8", 3/4" & 1" METER SERVICE THROUGH FLOOR INSTALLATION
 PENNICHUCK WATER WORKS, INC.
 REV: 02-20-2026 SCALE: NTS

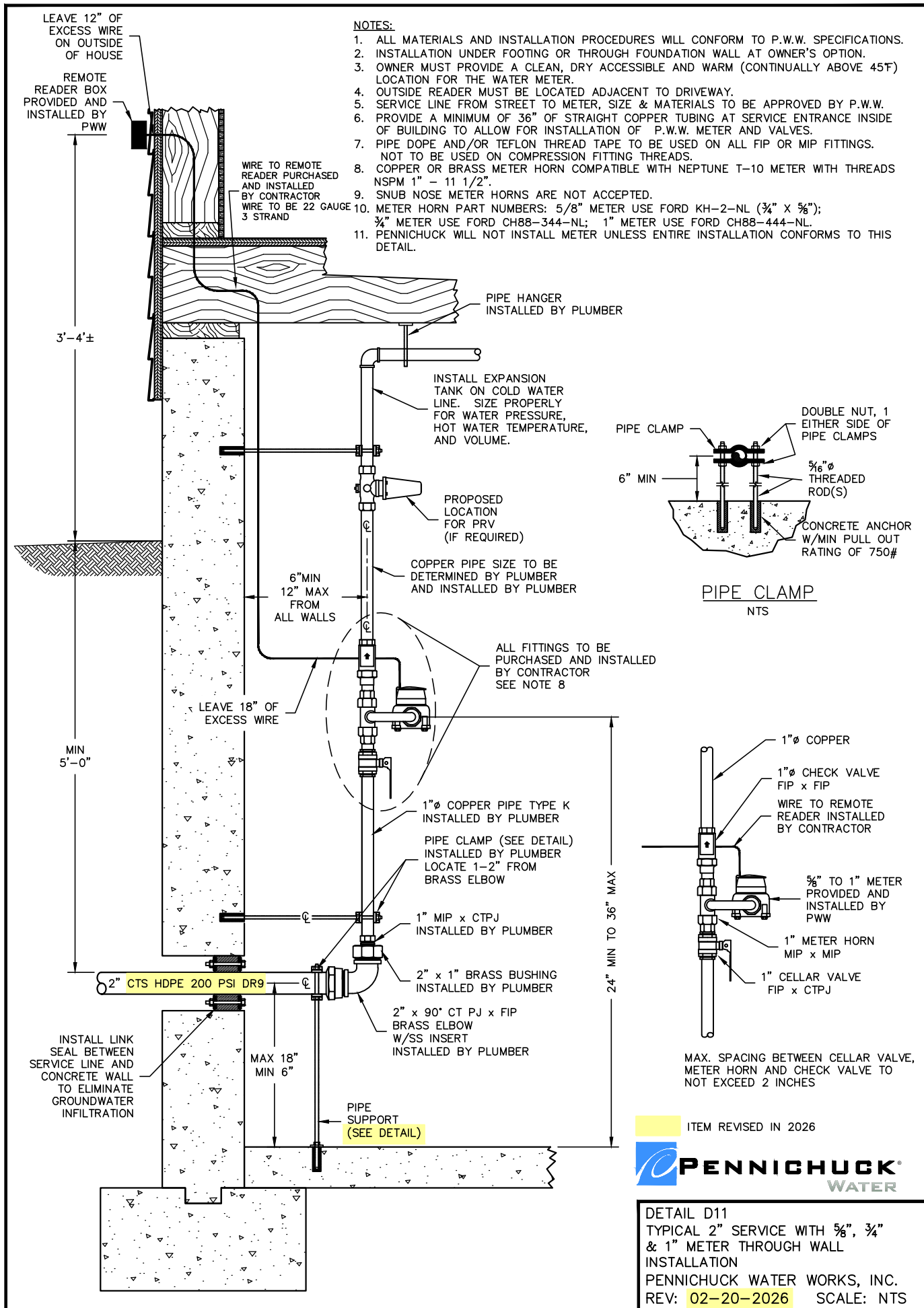

NOTES:

1. ALL MATERIALS AND INSTALLATION PROCEDURES WILL CONFORM TO P.W.W. SPECIFICATIONS.
2. INSTALLATION UNDER FOOTING OR THROUGH FOUNDATION WALL AT OWNER'S OPTION.
3. OWNER MUST PROVIDE A CLEAN, DRY ACCESSIBLE AND WARM (CONTINUALLY ABOVE 45°F) LOCATION FOR THE WATER METER.
4. OUTSIDE READER MUST BE LOCATED ADJACENT TO DRIVEWAY.
5. SERVICE LINE FROM STREET TO METER, SIZE & MATERIALS TO BE APPROVED BY P.W.W.
6. PROVIDE A MINIMUM OF 36" OF STRAIGHT COPPER TUBING AT SERVICE ENTRANCE INSIDE OF BUILDING TO ALLOW FOR INSTALLATION OF P.W.W. METER AND VALVES.
7. PIPE DOPE AND/OR TEFLON THREAD TAPE TO BE USED ON ALL FIP OR MIP FITTINGS. NOT TO BE USED ON COMPRESSION FITTING THREADS.
8. COPPER OR BRASS METER HORN COMPATIBLE WITH NEPTUNE T-10 METER WITH THREADS NSPM 1" - 11 1/2".
9. SNUB NOSE METER HORNS ARE NOT ACCEPTED.
10. METER HORN PART NUMBERS: 5/8" METER USE FORD KH-2-NL (3/4" X 5/8"); 3/4" METER USE FORD CH88-344-NL; 1" METER USE FORD CH88-444-NL.
11. PENNICHUCK WILL NOT INSTALL METER UNLESS ENTIRE INSTALLATION CONFORMS TO THIS DETAIL.

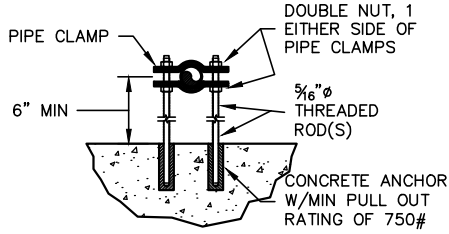

PIPE CLAMP
NTS

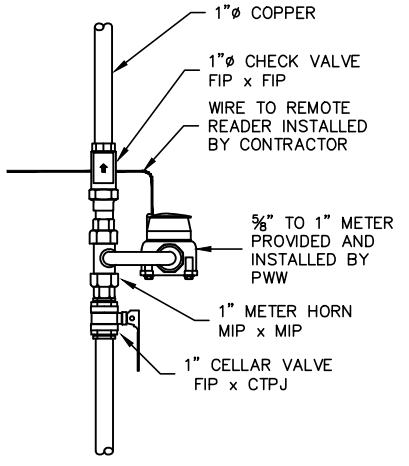

MAX. SPACING BETWEEN CELLAR VALVE, METER HORN AND CHECK VALVE TO NOT EXCEED 2 INCHES

ITEM REVISED IN 2026

DETAIL D11
TYPICAL 2" SERVICE WITH 5/8", 3/4" & 1" METER THROUGH WALL INSTALLATION
PENNICHUCK WATER WORKS, INC.
REV: 02-20-2026 SCALE: NTS

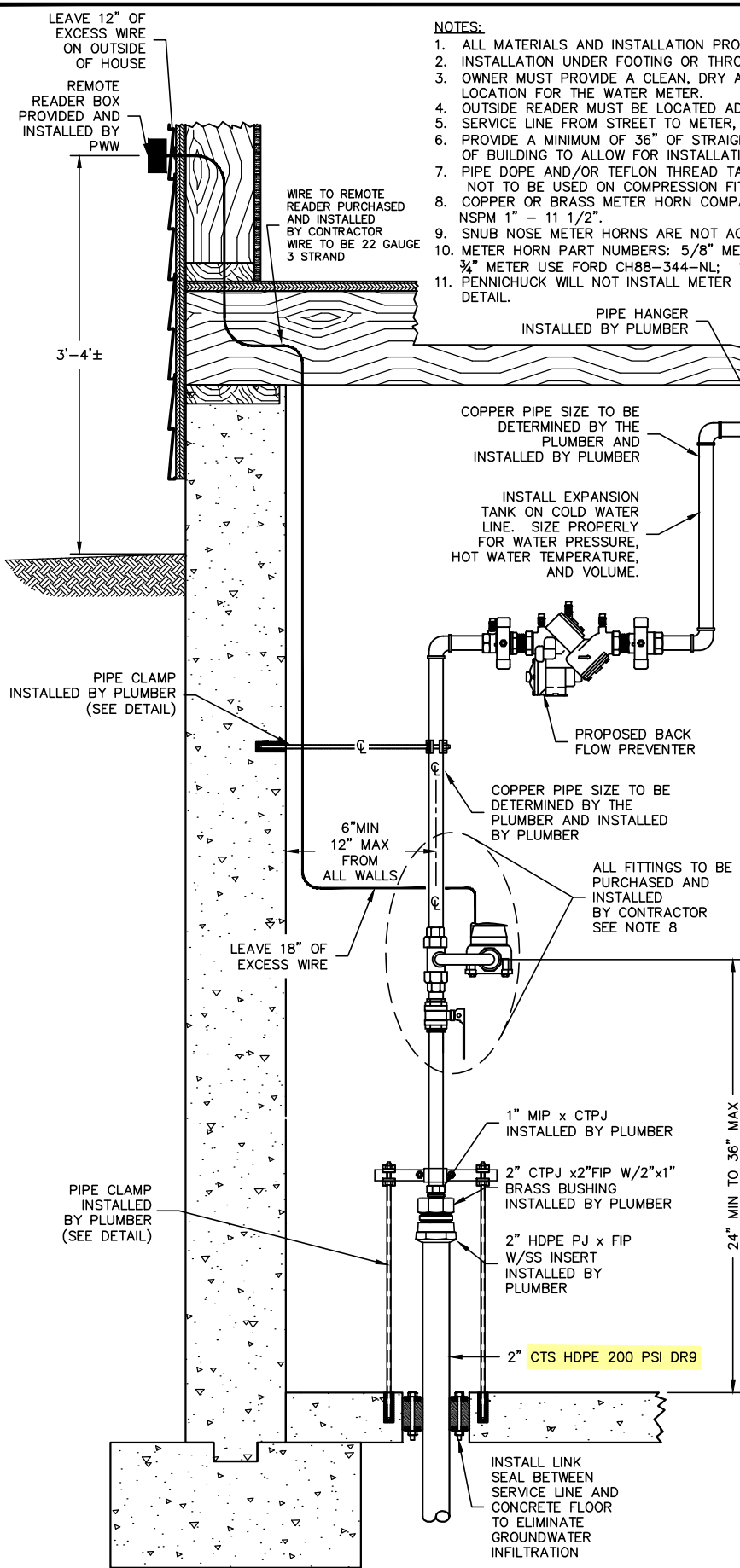

NOTES:

1. ALL MATERIALS AND INSTALLATION PROCEDURES WILL CONFORM TO P.W.W. SPECIFICATIONS.
2. INSTALLATION UNDER FOOTING OR THROUGH FOUNDATION WALL AT OWNER'S OPTION.
3. OWNER MUST PROVIDE A CLEAN, DRY ACCESSIBLE AND WARM (CONTINUALLY ABOVE 45°F) LOCATION FOR THE WATER METER.
4. OUTSIDE READER MUST BE LOCATED ADJACENT TO DRIVEWAY.
5. SERVICE LINE FROM STREET TO METER, SIZE & MATERIALS TO BE APPROVED BY P.W.W.
6. PROVIDE A MINIMUM OF 36" OF STRAIGHT COPPER TUBING AT SERVICE ENTRANCE INSIDE OF BUILDING TO ALLOW FOR INSTALLATION OF P.W.W. METER AND VALVES.
7. PIPE DOPE AND/OR TEFLON THREAD TAPE TO BE USED ON ALL FIP OR MIP FITTINGS. NOT TO BE USED ON COMPRESSION FITTING THREADS.
8. COPPER OR BRASS METER HORN COMPATIBLE WITH NEPTUNE T-10 METER WITH THREADS NSPM 1" - 1 1/2".
9. SNUB NOSE METER HORNS ARE NOT ACCEPTED.
10. METER HORN PART NUMBERS: 5/8" METER USE FORD KH-2-NL (3/4" x 5/8"); 3/4" METER USE FORD CH88-344-NL; 1" METER USE FORD CH88-444-NL.
11. PENNICHUCK WILL NOT INSTALL METER UNLESS ENTIRE INSTALLATION CONFORMS TO THIS DETAIL.

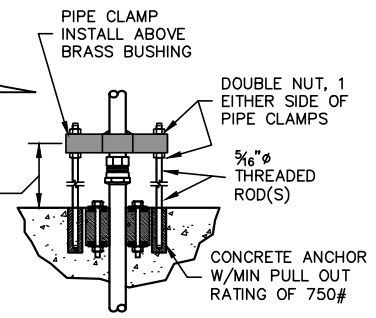

PIPE CLAMP (FLOOR)
NTS

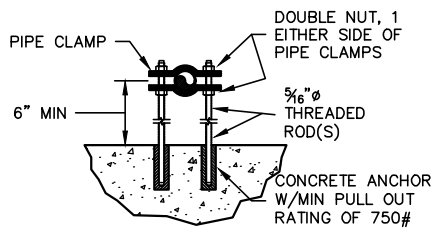

PIPE CLAMP (WALL)
NTS

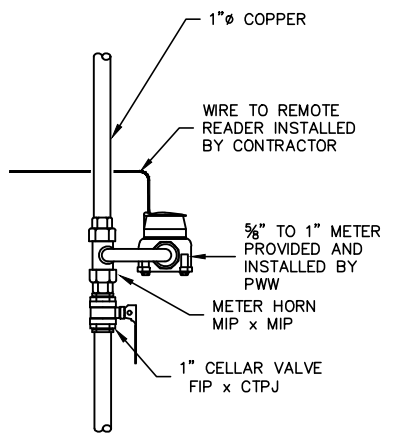

MAX. SPACING BETWEEN CELLAR VALVE, METER HORN AND CHECK VALVE TO NOT EXCEED 2 INCHES

ITEM REVISED IN 2026



DETAIL D12
 TYPICAL 2" SERVICE WITH BACK FLOW AND 5/8", 3/4" & 1" METER SERVICE THROUGH FLOOR INSTALLATION
 PENNICHUCK WATER WORKS, INC.
 REV: 02-20-2026 SCALE: NTS

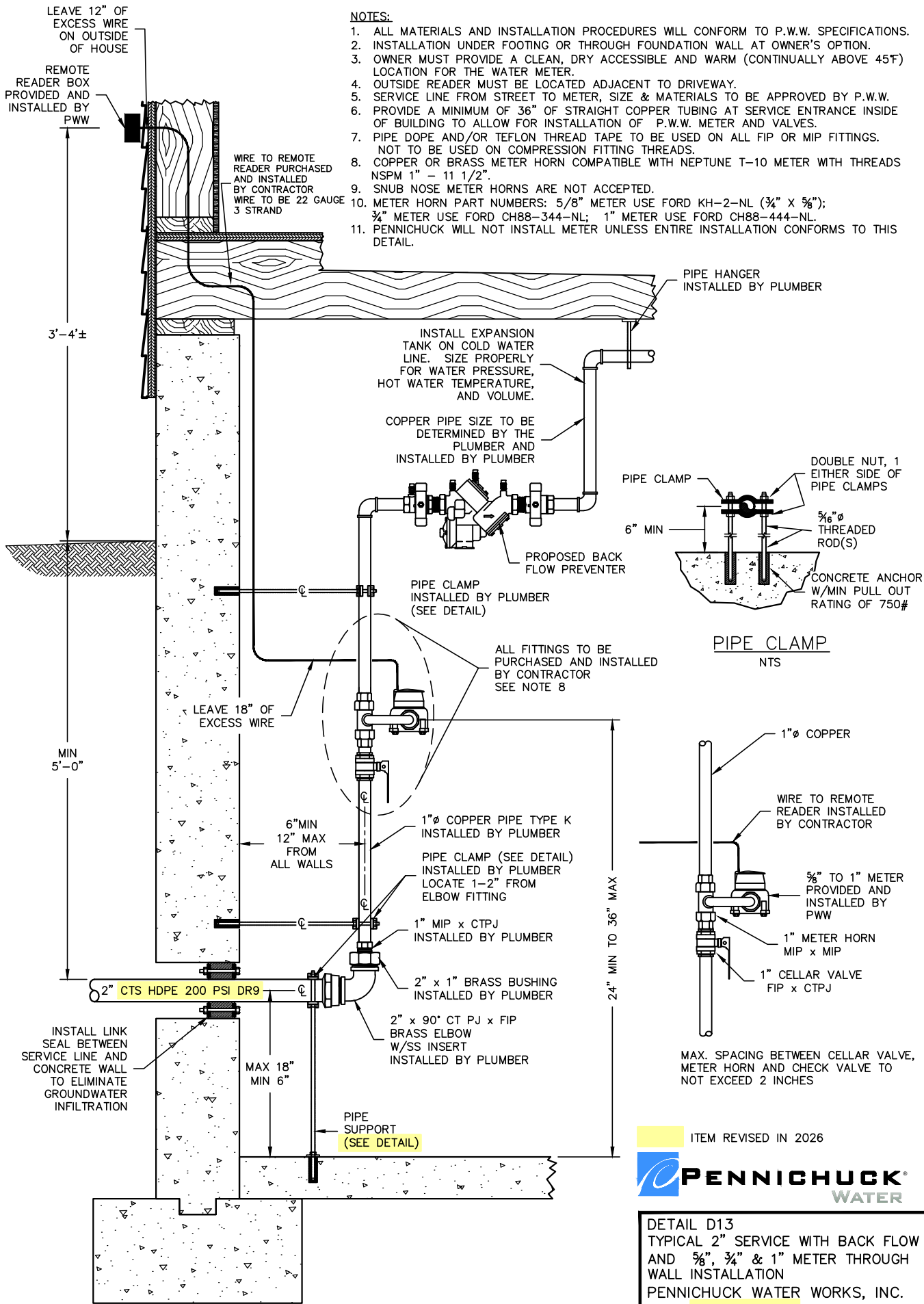

NOTES:

1. ALL MATERIALS AND INSTALLATION PROCEDURES WILL CONFORM TO P.W.W. SPECIFICATIONS.
2. INSTALLATION UNDER FOOTING OR THROUGH FOUNDATION WALL AT OWNER'S OPTION.
3. OWNER MUST PROVIDE A CLEAN, DRY ACCESSIBLE AND WARM (CONTINUALLY ABOVE 45°F) LOCATION FOR THE WATER METER.
4. OUTSIDE READER MUST BE LOCATED ADJACENT TO DRIVEWAY.
5. SERVICE LINE FROM STREET TO METER, SIZE & MATERIALS TO BE APPROVED BY P.W.W.
6. PROVIDE A MINIMUM OF 36" OF STRAIGHT COPPER TUBING AT SERVICE ENTRANCE INSIDE OF BUILDING TO ALLOW FOR INSTALLATION OF P.W.W. METER AND VALVES.
7. PIPE DOPE AND/OR TEFLON THREAD TAPE TO BE USED ON ALL FIP OR MIP FITTINGS. NOT TO BE USED ON COMPRESSION FITTING THREADS.
8. COPPER OR BRASS METER HORN COMPATIBLE WITH NEPTUNE T-10 METER WITH THREADS NSPM 1" - 11 1/2".
9. SNUB NOSE METER HORNS ARE NOT ACCEPTED.
10. METER HORN PART NUMBERS: 5/8" METER USE FORD KH-2-NL (3/4" x 5/8"); 3/4" METER USE FORD CH88-344-NL; 1" METER USE FORD CH88-444-NL.
11. PENNICHUCK WILL NOT INSTALL METER UNLESS ENTIRE INSTALLATION CONFORMS TO THIS DETAIL.

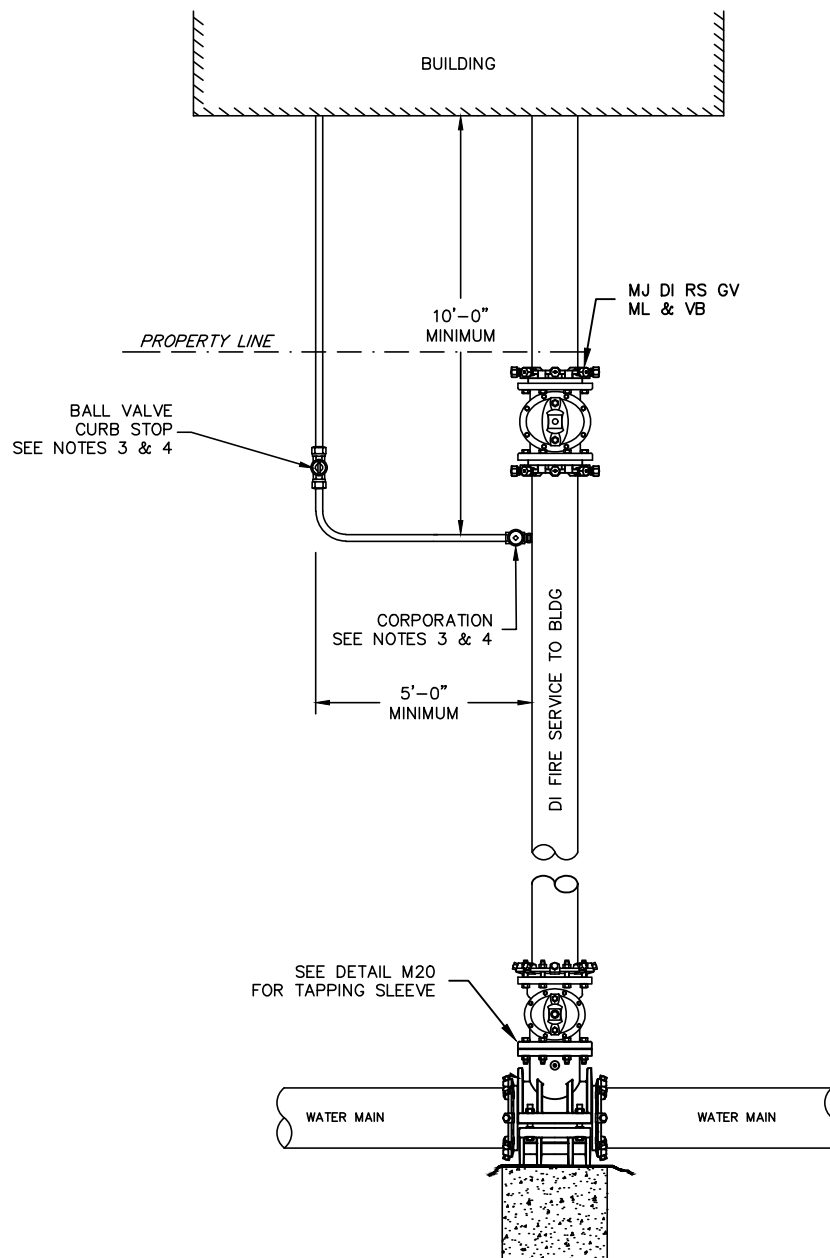

NOTES:

1. ALL MATERIALS AND INSTALLATION PROCEDURES WILL CONFORM TO P.W.W. TECHNICAL SPECIFICATIONS.
2. ALL PIPE SHOULD HAVE A MINIMUM DEPTH OF 5' FROM TOP OF PIPE TO FINISH GRADE.
3. SEE DETAIL D01 AND D03 FOR 1" THROUGH 2" SERVICE AND VALVE BOX INSTALLATION DETAIL.
4. SEE DETAIL M01 FOR TYPICAL SERVICE UTILITY SEPARATION ENTRANCE.

ITEM REVISED IN 2026



DETAIL D15
COMMERCIAL SERVICE TAPPED OFF
FIRE SERVICE (2" OR SMALLER)
 PENNICHUCK WATER WORKS, INC.
 REV: 02-20-2026 SCALE: NTS

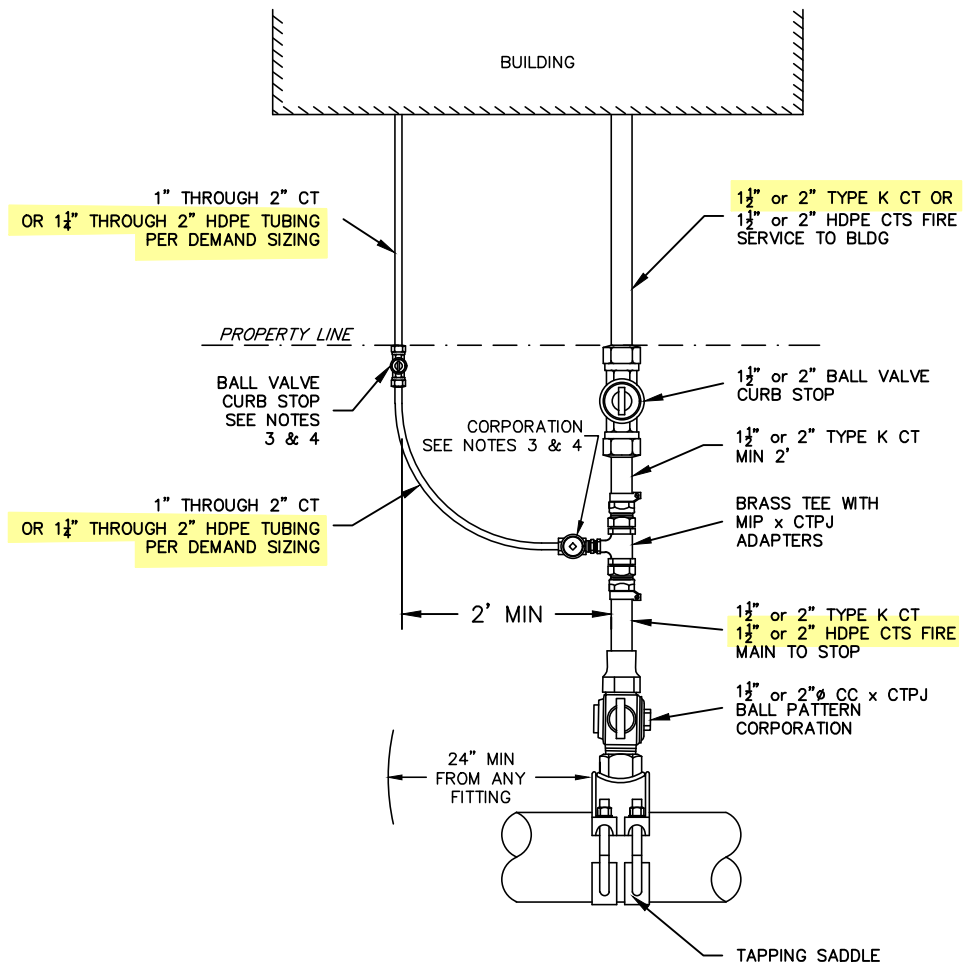

NOTES:

1. ALL MATERIALS AND INSTALLATION PROCEDURES WILL CONFORM TO P.W.W. TECHNICAL SPECIFICATIONS.
2. ALL PIPE SHOULD HAVE A MINIMUM DEPTH OF 5' FROM TOP OF PIPE TO FINISH GRADE.
3. INSTALLATION DETAIL. SEE DETAIL D01 FOR 1" THROUGH 2" SIZED SERVICES.
4. SEE DETAIL M01 FOR TYPICAL SERVICE UTILITY SEPARATION ENTRANCE.

ITEM REVISED IN 2026



DETAIL D16
 RESIDENTIAL SERVICE TAPPED OFF
 FIRE SERVICE; 1" TO 2"
 PENNICHUCK WATER WORKS, INC.
 REV: 02-20-2026 SCALE: NTS

BUILDING

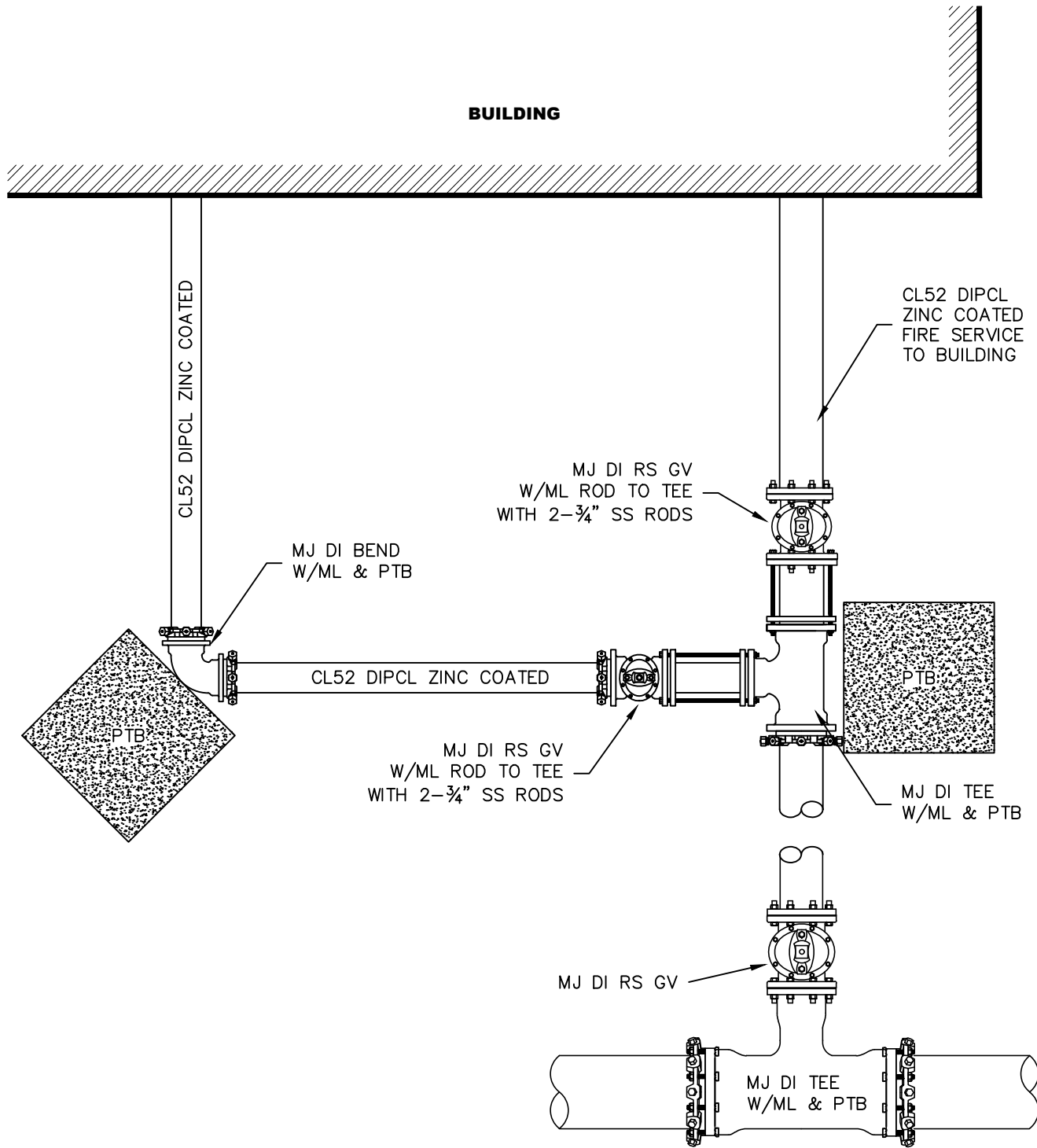

NOTES:

1. ALL MATERIALS AND INSTALLATION PROCEDURES WILL CONFORM TO P.W.W. TECHNICAL SPECIFICATIONS.
2. ALL PIPE SHOULD HAVE A MINIMUM DEPTH OF 5' FROM TOP OF PIPE TO FINISH GRADE.

ITEM REVISED IN 2026



DETAIL D17
COMMERCIAL SERVICE OFF FIRE SERVICE 4" OR LARGER
PENNICHUCK WATER WORKS, INC.
REV: 02-22-2026 SCALE: NTS

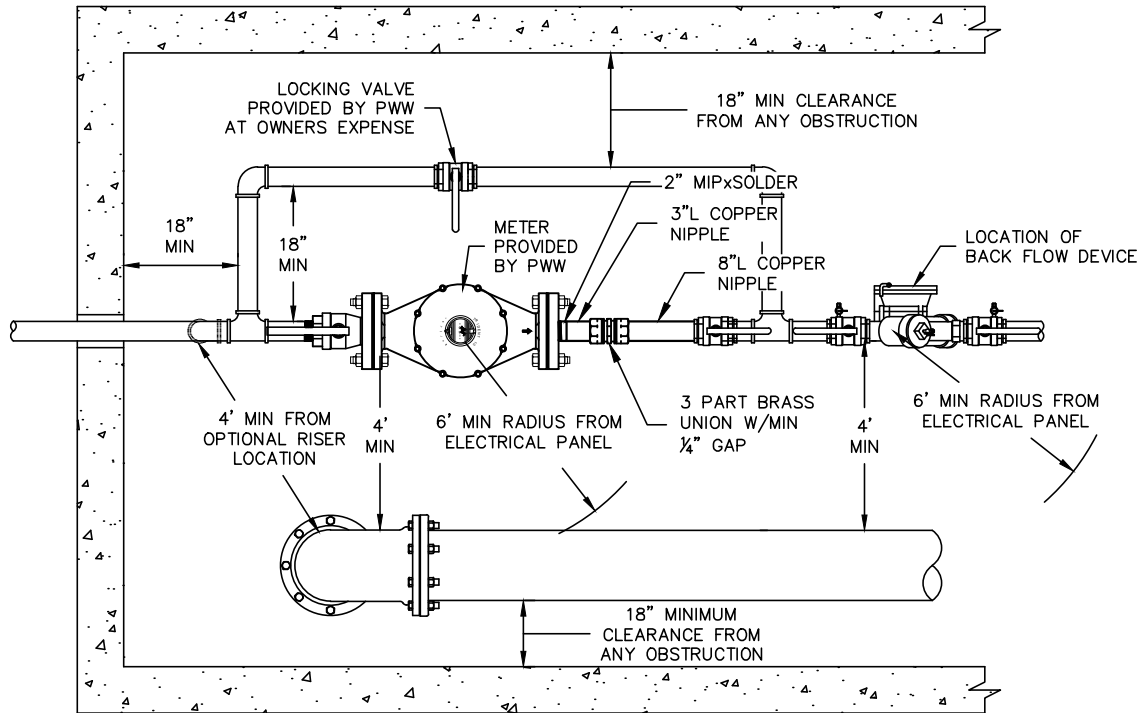

TOP VIEW

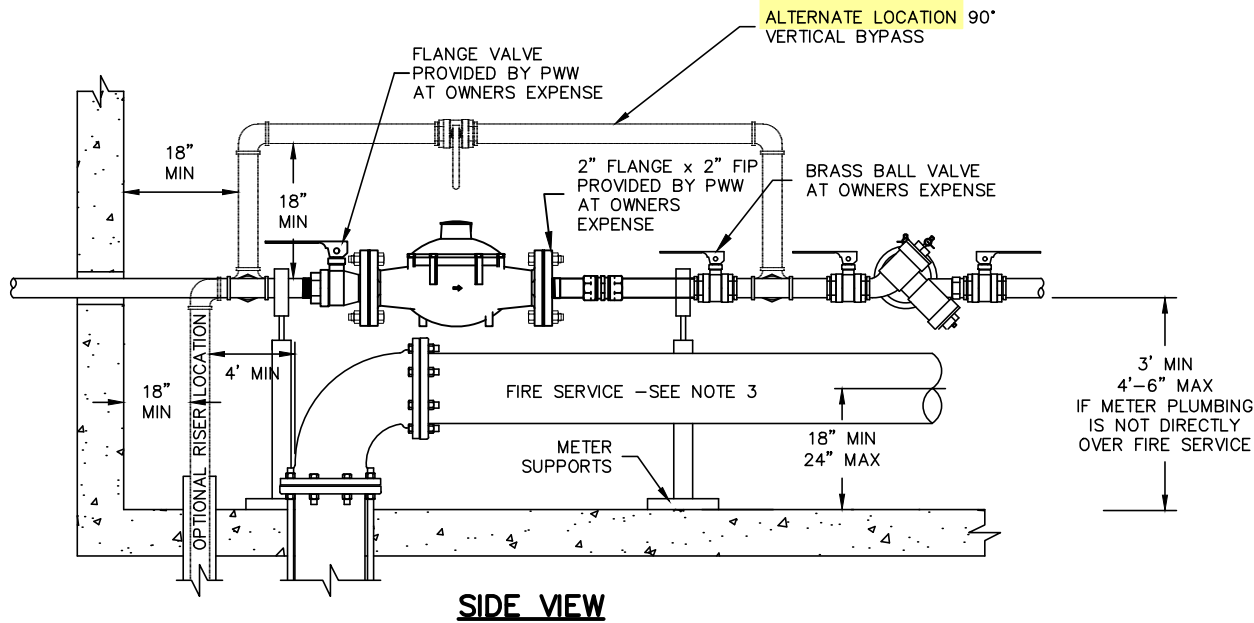

SIDE VIEW

NOTES:

1. ALL MATERIALS AND INSTALLATION PROCEDURES WILL CONFORM TO P.W.W. TECHNICAL SPECIFICATIONS.
2. PRV WHEN NECESSARY WILL BE INSTALLED AND PURCHASED BY OWNER OR CONTRACTOR.
3. BACK FLOW PREVENTOR REQUIRED ON ALL FIRE SERVICES. TYPE AND LOCATION SUBJECT TO P.W.W. APPROVAL.
4. ANY ELECTRICAL PANEL MUST MAINTAIN A 6' MINIMUM RADIUS FROM METER AND BACK FLOW.
5. 1 1/2" METER = 13" LAYING LENGTH.
6. 2" METER = 17" LAYING LENGTH.
7. MINIMUM OF 10 PIPE DIAMETERS OF STRAIGHT RUN PIPE IS REQUIRED UPSTREAM OF THE METER.

ITEM REVISED IN 2026



DETAIL D18
 1 1/2" & 2" POSITIVE
 DISPLACEMENT METER
 COMBINED FIRE AND DOMESTIC
 SERVICE ENTRANCE DETAIL
 PENNICHUCK WATER WORKS, INC.
 REV: 02-20-2026 SCALE: NTS

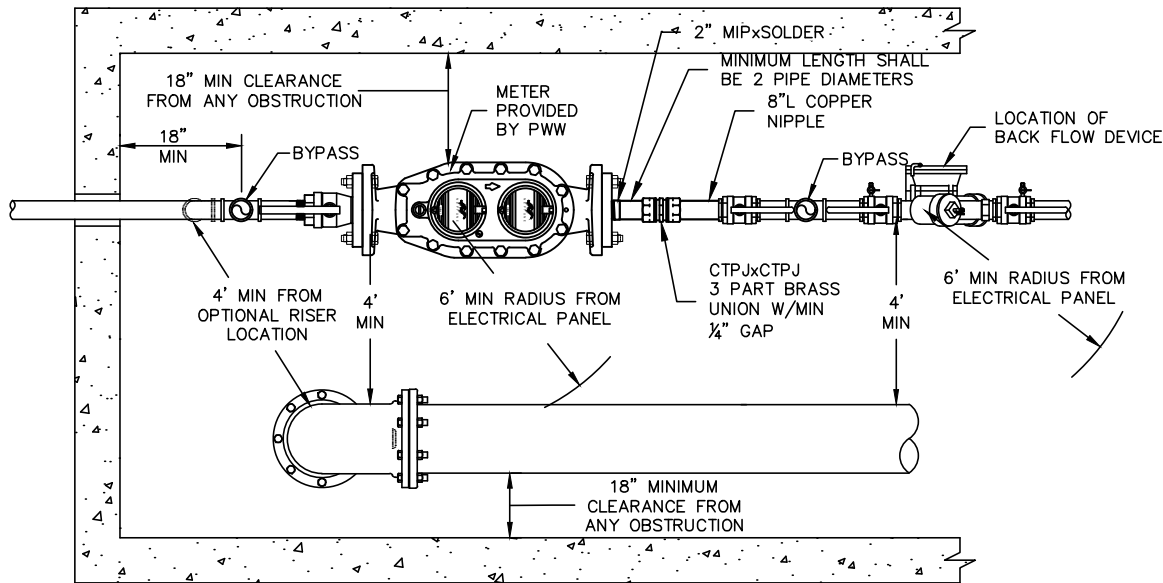

TOP VIEW

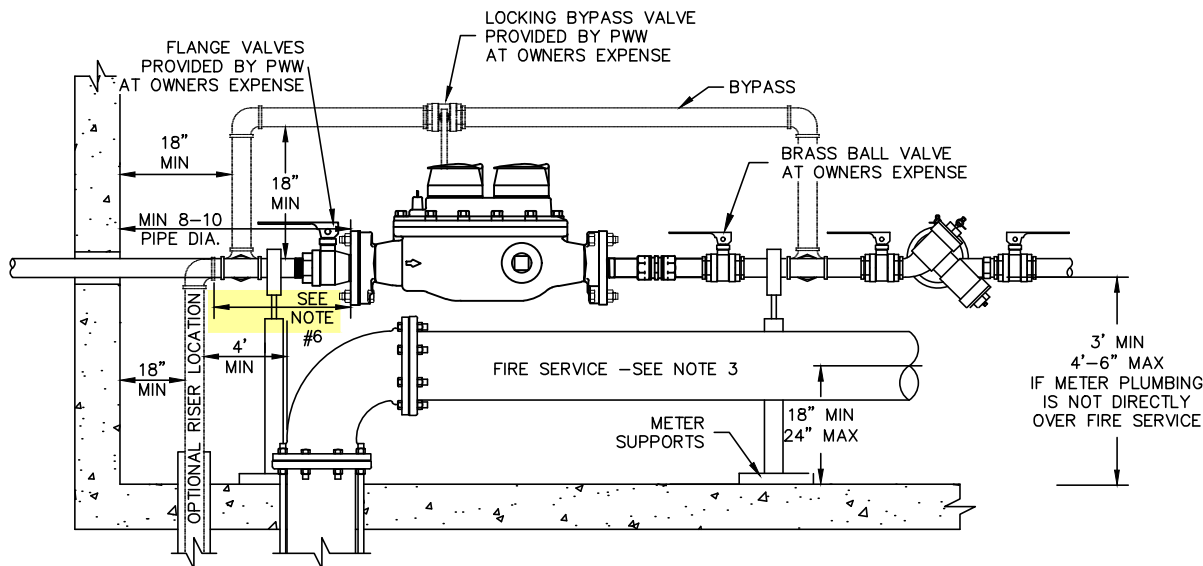

SIDE VIEW

NOTES:

1. ALL MATERIALS AND INSTALLATION PROCEDURES WILL CONFORM TO P.W.W. TECHNICAL SPECIFICATIONS.
2. PRV WHEN NECESSARY WILL BE INSTALLED AND PURCHASED BY OWNER OR CONTRACTOR.
3. BACK FLOW PREVENTOR REQUIRED ON ALL FIRE SERVICES. TYPE AND LOCATION SUBJECT TO P.W.W. APPROVAL.
4. ANY ELECTRICAL PANEL MUST MAINTAIN A 6' MINIMUM RADIUS FROM METER AND BACK FLOW.
5. 2" COMPOUND METER = 15 1/4" LAYING LENGTH OF METER.
6. MINIMUM OF 8 PIPE DIAMETERS OF STRAIGHT RUN PIPE IS REQUIRED UPSTREAM OF THE METER IF NO STRAINER IS INSTALLED. IF A STRAINER IS INSTALLED, THIS LENGTH CAN BE REDUCED TO 4 PIPE DIAMETERS. A MINIMUM OF 2 PIPE DIAMETERS OF STRAIGHT RUN PIPE IS REQUIRED DOWNSTREAM OF THE METER AND STRAINER ASSEMBLY.

ITEM REVISED IN 2026



DETAIL D19
2" TRU/FLO COMPOUND METER
COMBINED FIRE AND DOMESTIC
SERVICE ENTRANCE DETAIL
 PENNICHUCK WATER WORKS, INC.
 REV: 03-15-2026 SCALE: NTS

NOTES:

1. ALL MATERIALS AND INSTALLATION PROCEDURES WILL CONFORM TO P.W.W. TECHNICAL SPECIFICATIONS.
2. PRV WHEN NECESSARY WILL BE INSTALLED AND PURCHASED BY OWNER OR CONTRACTOR.
3. BACK FLOW PREVENTOR REQUIRED ON ALL FIRE SERVICES. TYPE AND LOCATION SUBJECT TO P.W.W. APPROVAL.
4. ANY ELECTRICAL PANEL MUST MAINTAIN A 6' MINIMUM RADIUS FROM METER AND BACK FLOW.
5. METER PLUMBING MAY BE INSTALLED DIRECTLY OVER THE FIRE SERVICE PROVIDED THAT 2' CLEARANCE IS MAINTAINED AND 4' MINIMUM CLEARANCE FROM ANY OBSTRUCTION IS ALSO MAINTAINED.
6. MINIMUM OF 8 PIPE DIAMETERS OF STRAIGHT RUN PIPE IS REQUIRED UPSTREAM OF THE METER IF NO STRAINER IS INSTALLED. IF A STRAINER IS INSTALLED, THIS LENGTH CAN BE REDUCED TO 4 PIPE DIAMETERS. A MINIMUM OF 2 PIPE DIAMETERS OF STRAIGHT RUN PIPE IS REQUIRED DOWNSTREAM OF THE METER AND STRAINER ASSEMBLY.

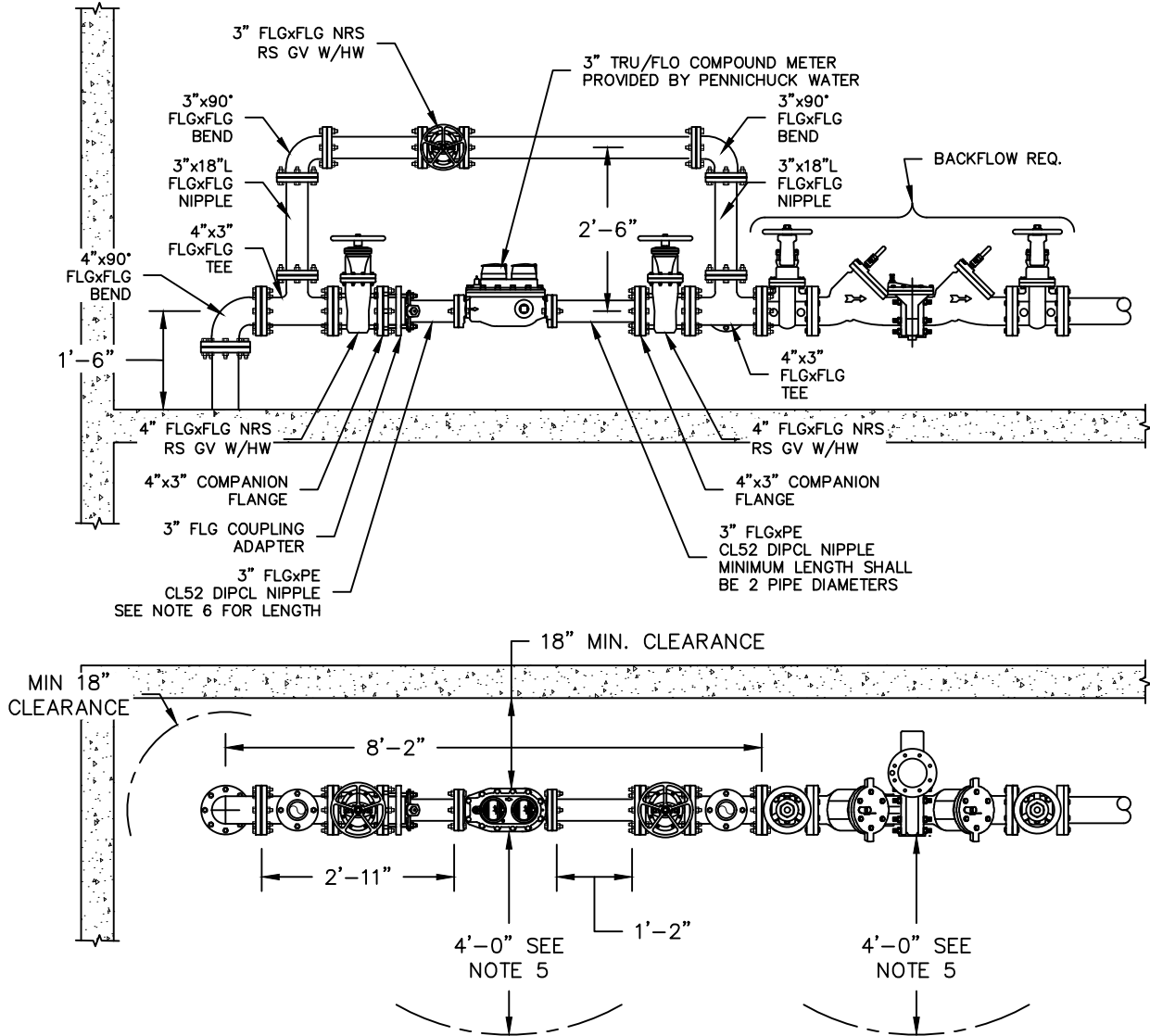

ITEM REVISED IN 2026



DETAIL D20
3" METER DETAIL
 PENNICHUCK WATER WORKS, INC.
 REV: 03-15-2026 SCALE: NTS

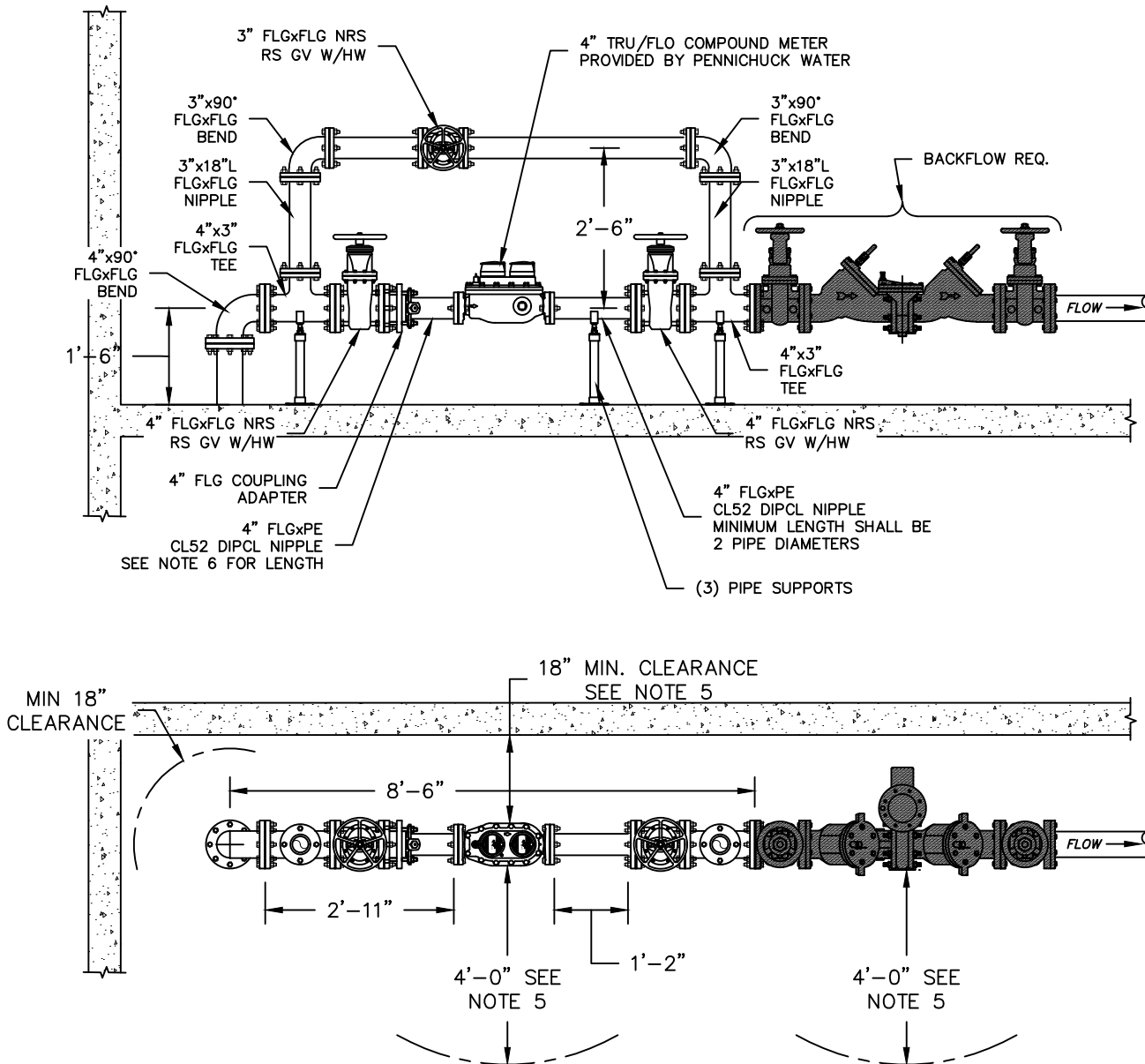

NOTES:

1. ALL MATERIALS AND INSTALLATION PROCEDURES WILL CONFORM TO P.W.W. TECHNICAL SPECIFICATIONS.
2. PRV WHEN NECESSARY WILL BE INSTALLED AND PURCHASED BY OWNER OR CONTRACTOR.
3. BACK FLOW PREVENTOR REQUIRED ON ALL FIRE SERVICES. TYPE AND LOCATION SUBJECT TO P.W.W. APPROVAL.
4. ANY ELECTRICAL PANEL MUST MAINTAIN A 6' MINIMUM RADIUS FROM METER AND BACK FLOW.
5. METER PLUMBING MAY BE INSTALLED DIRECTLY OVER THE FIRE SERVICE PROVIDED THAT 2' CLEARANCE IS MAINTAINED AND 4' MINIMUM CLEARANCE FROM ANY OBSTRUCTION IS ALSO MAINTAINED.
6. MINIMUM OF 8 PIPE DIAMETERS OF STRAIGHT RUN PIPE IS REQUIRED UPSTREAM OF THE METER IF NO STRAINER IS INSTALLED. IF A STRAINER IS INSTALLED, THIS LENGTH CAN BE REDUCED TO 4 PIPE DIAMETERS. A MINIMUM OF 2 PIPE DIAMETERS OF STRAIGHT RUN PIPE IS REQUIRED DOWNSTREAM OF THE METER AND STRAINER ASSEMBLY.

ITEM REVISED IN 2026



DETAIL D21

4" METER DETAIL

PENNICHUCK WATER WORKS, INC.

REV: 03-15-2026 SCALE: NTS

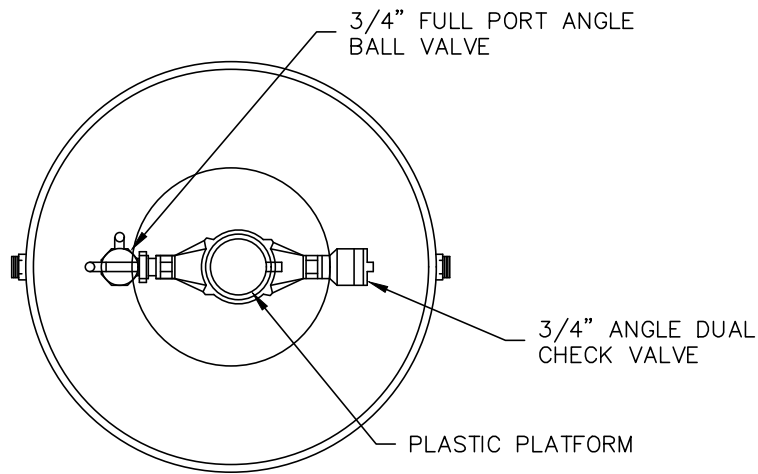

PLAN VIEW

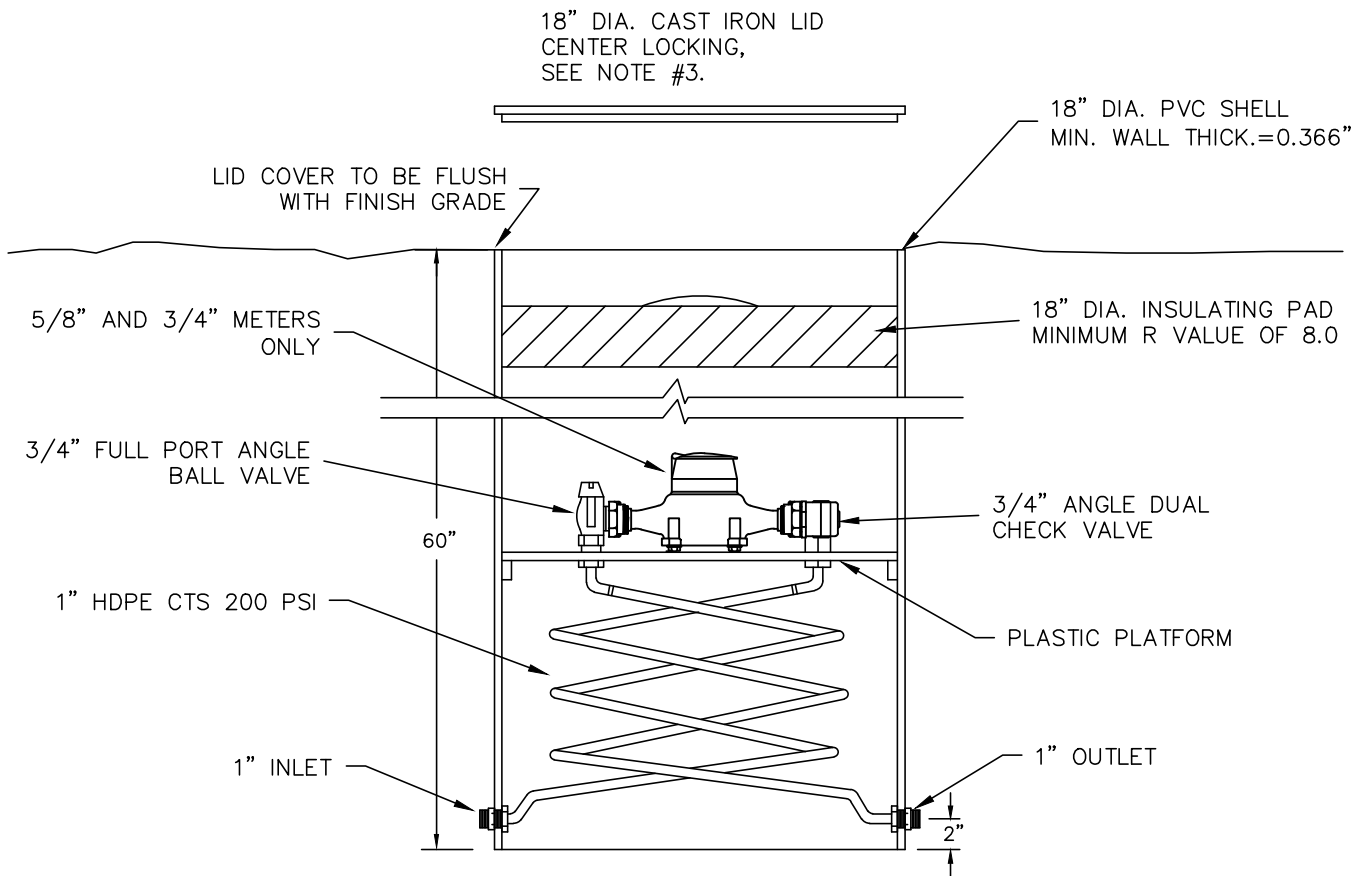

ELEVATION VIEW

NOTES:

1. PENNICHUCK WILL PROVIDE AND INSTALL METER IF INSTALLATION CONFORMS TO THIS DETAIL..
2. METER PIT SHALL BE MUELLER HUNT MODEL 203CS1860, FORD 18360-NL, AY McDONALD 790 OR APPROVED EQUAL.
3. PITS INSTALLED IN OR NEAR DRIVEWAYS MUST HAVE AN APPROVED FRAME AND COVER WITH A MINIMUM 20,000 POUND LOAD RATING.
4. ALL COVERS MUST HAVE LOCKING LIDS WITH ELECTRONIC READ CAPABILITIES.



DETAIL D22
18" DIAMETER COIL SINGLE
METER PIT
 PENNICHUCK WATER WORKS, INC.
 DATE: 02-20-2026 SCALE: NTS

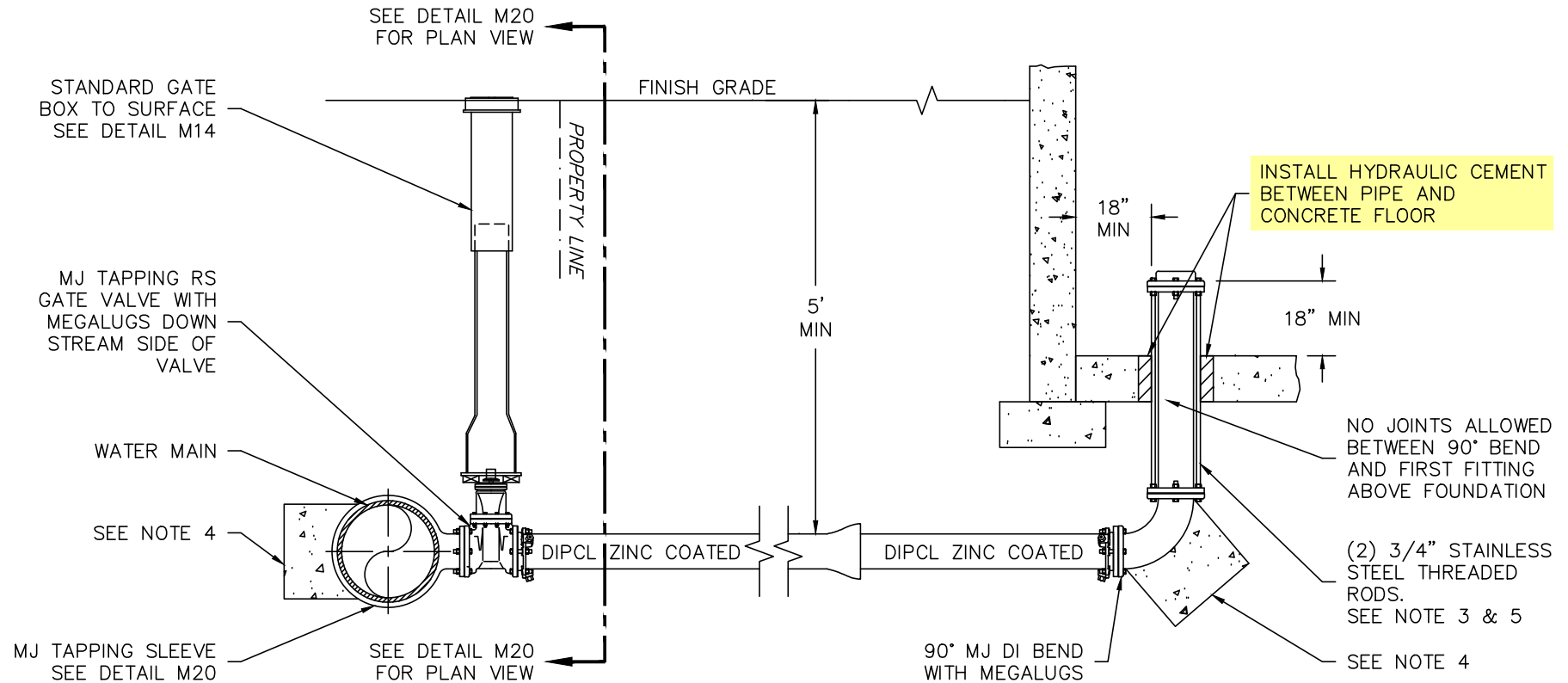

NOTES:

1. ALL MATERIALS AND INSTALLATION PROCEDURES WILL CONFORM TO P.W.W. TECHNICAL SPECIFICATIONS.
2. ALL PIPE SHOULD HAVE A MINIMUM DEPTH OF 5' FROM TOP OF PIPE TO FINISH GRADE.
3. 3/4"φ S.S. RODS SHALL BE USED IN CONJUNCTION WITH REQUIRED S.S. NUTS. RODS ARE TO BE ATTACHED TO FITTINGS WITH EITHER STAR BOLTS OR DUC LUGS. PER SPECIFICATION SECTION 01600.C.16.F
 10" FITTING OR SMALLER = (2) 3/4"φ S.S. RODS & ASSOC. HARDWARE.
 12" FITTING OR LARGER = (4) 3/4"φ S.S. RODS & ASSOC. HARDWARE.
4. MIN 2'x2'x3' PRE CAST CONCRETE THRUST BLOCK MAY BE USED WITH P.W.W. APPROVAL OR CONCRETE THRUST BLOCK POURED AGAINST UNDISTURBED EARTH – SIZE TO BE BASED ON SIZE OF FITTING AND PRESSURE IN WATER MAIN. SEE DETAIL M10.
5. ALL MECHANICAL JOINT FITTINGS SEPARATED BY PIPE LENGTH OF 10 FEET OR LESS MUST BE RODDED PER PWW TECHNICAL SPECIFICATION SECTION 01600E.2.F

ITEM REVISED IN 2026



DETAIL F01
FIRE SERVICE 4" OR LARGER
THRU FLOOR INSTALLATION DETAIL
 PENNICHUCK WATER WORKS, INC.
 REV: 02-20-2026 SCALE: NTS

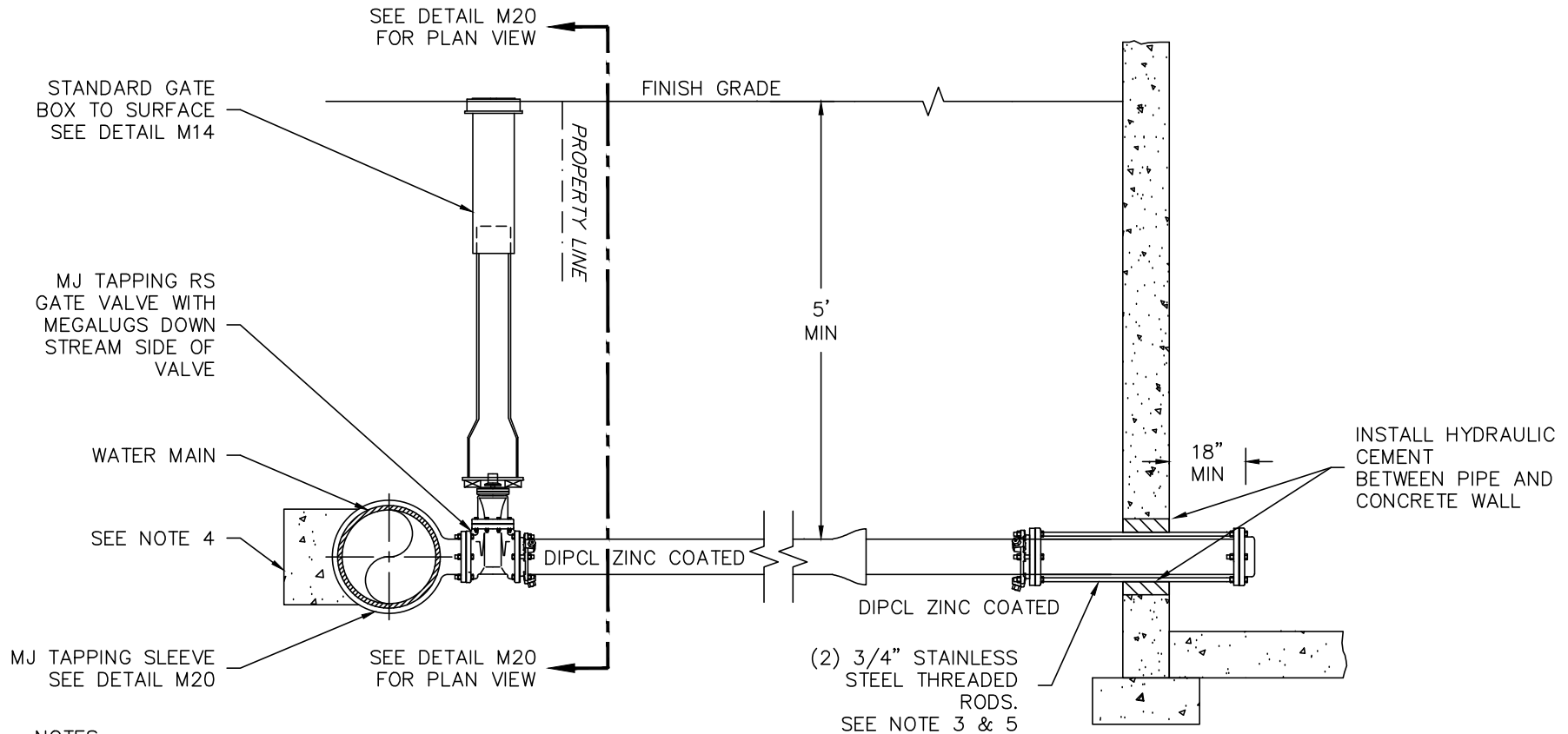

NOTES:

1. ALL MATERIALS AND INSTALLATION PROCEDURES WILL CONFORM TO P.W.W. TECHNICAL SPECIFICATIONS.
2. ALL PIPE SHOULD HAVE A MINIMUM DEPTH OF 5' FROM TOP OF PIPE TO FINISH GRADE.
3. 3/4" ϕ S.S. RODS SHALL BE USED IN CONJUNCTION WITH REQUIRED S.S. NUTS. RODS ARE TO BE ATTACHED TO FITTINGS WITH EITHER STAR BOLTS OR DUC LUGS. PER SPECIFICATION SECTION 01600.C.16.F
 10" FITTING OR SMALLER = (2) 3/4" ϕ S.S. RODS & ASSOC. HARDWARE.
 12" FITTING OR LARGER = (4) 3/4" ϕ S.S. RODS & ASSOC. HARDWARE.
4. MIN 2'x2'x3' PRE CAST CONCRETE THRUST BLOCK MAY BE USED WITH P.W.W. APPROVAL OR CONCRETE THRUST BLOCK POURED AGAINST UNDISTURBED EARTH - SIZE TO BE BASED ON SIZE OF FITTING AND PRESSURE IN WATER MAIN. SEE DETAIL M10.
5. ALL MECHANICAL JOINT FITTINGS SEPARATED BY PIPE LENGTH OF 10 FEET OR LESS MUST BE RODDED PER PWW TECHNICAL SPECIFICATION SECTION 01600E.2.F



DETAIL F02
 FIRE SERVICE 4" OR LARGER
 THRU WALL INSTALLATION DETAIL
 PENNICHUCK WATER WORKS, INC.
 REV: 02-20-2026 SCALE: NTS

NOTES:

1. ALL MATERIALS AND INSTALLATION PROCEDURES WILL CONFORM TO P.W.W. SPECIFICATIONS.
2. INSTALLATION UNDER FOOTING OR THROUGH FOUNDATION WALL AT OWNER'S OPTION.
3. OWNER MUST PROVIDE A CLEAN, DRY ACCESSIBLE AND WARM (CONTINUALLY ABOVE 45°F) LOCATION FOR THE BACKFLOW PREVENTER.
4. SERVICE LINE FROM STREET SIZE & MATERIALS TO BE APPROVED BY P.W.W.
5. PIPE DOPE AND/OR TEFLON THREAD TAPE TO BE USED ON ALL FIP OR MIP FITTINGS. NOT TO BE USED ON COMPRESSION FITTING THREADS.

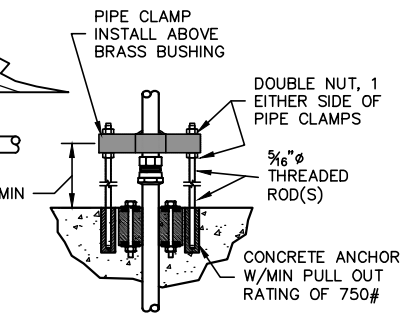
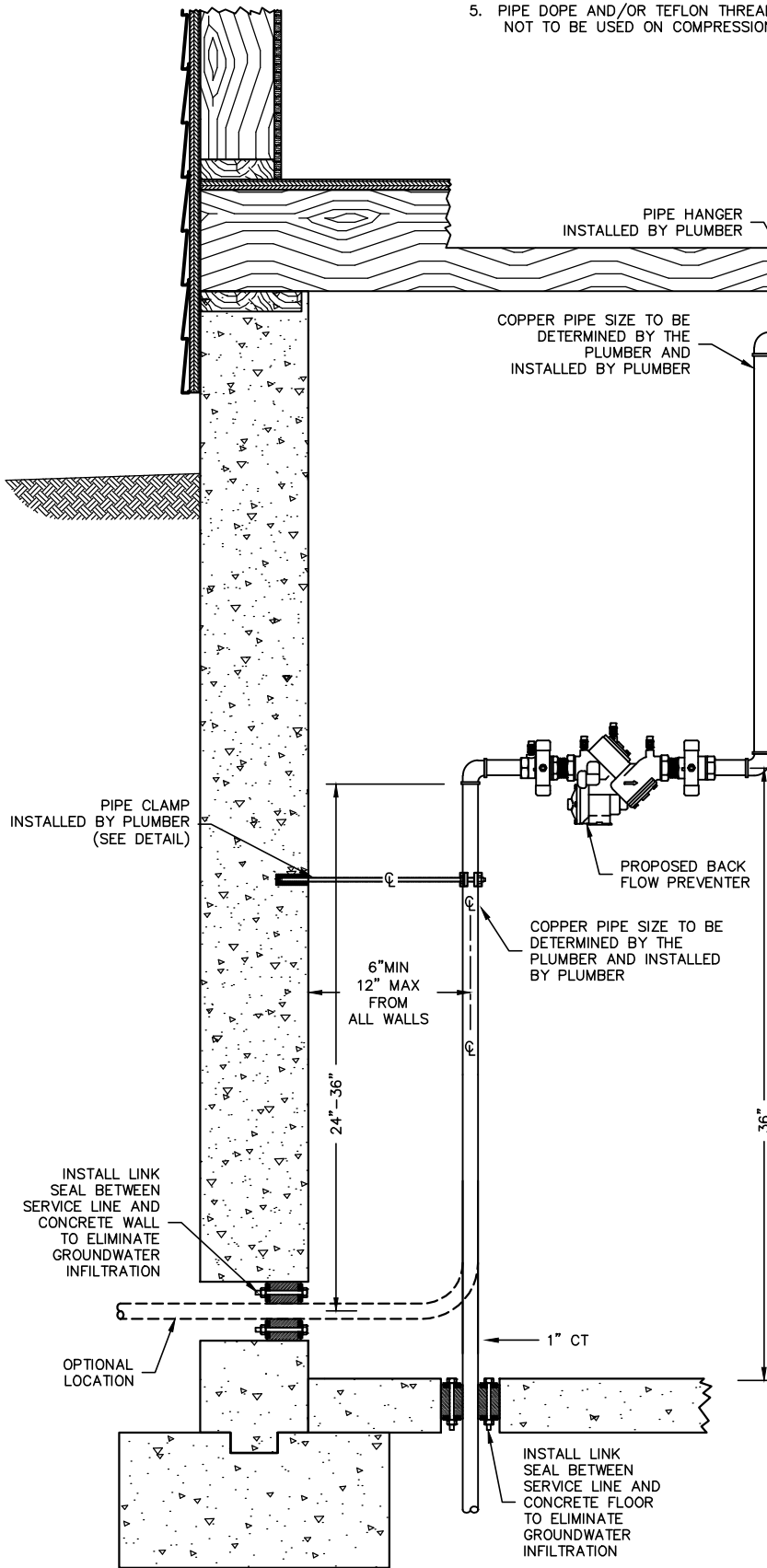

PIPE CLAMP (FLOOR)
NTS

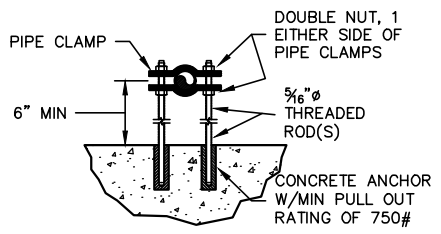

PIPE CLAMP (WALL)
NTS



DETAIL F03
1" CT FIRE SERVICE CONNECTION

PENNICHUCK WATER WORKS, INC.
DATE: 02-20-2026 SCALE: NTS

NOTES:

1. ALL MATERIALS AND INSTALLATION PROCEDURES WILL CONFORM TO P.W.W. SPECIFICATIONS.
2. INSTALLATION UNDER FOOTING OR THROUGH FOUNDATION WALL AT OWNER'S OPTION.
3. OWNER MUST PROVIDE A CLEAN, DRY ACCESSIBLE AND WARM (CONTINUALLY ABOVE 45°F) LOCATION FOR THE BACKFLOW PREVENTER.
4. SERVICE LINE FROM STREET SIZE & MATERIALS TO BE APPROVED BY P.W.W.
5. PIPE DOPE AND/OR TEFLON THREAD TAPE TO BE USED ON ALL FIP OR MIP FITTINGS. NOT TO BE USED ON COMPRESSION FITTING THREADS.

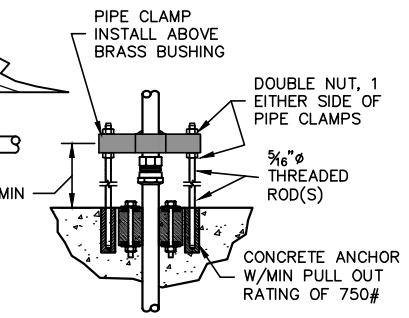
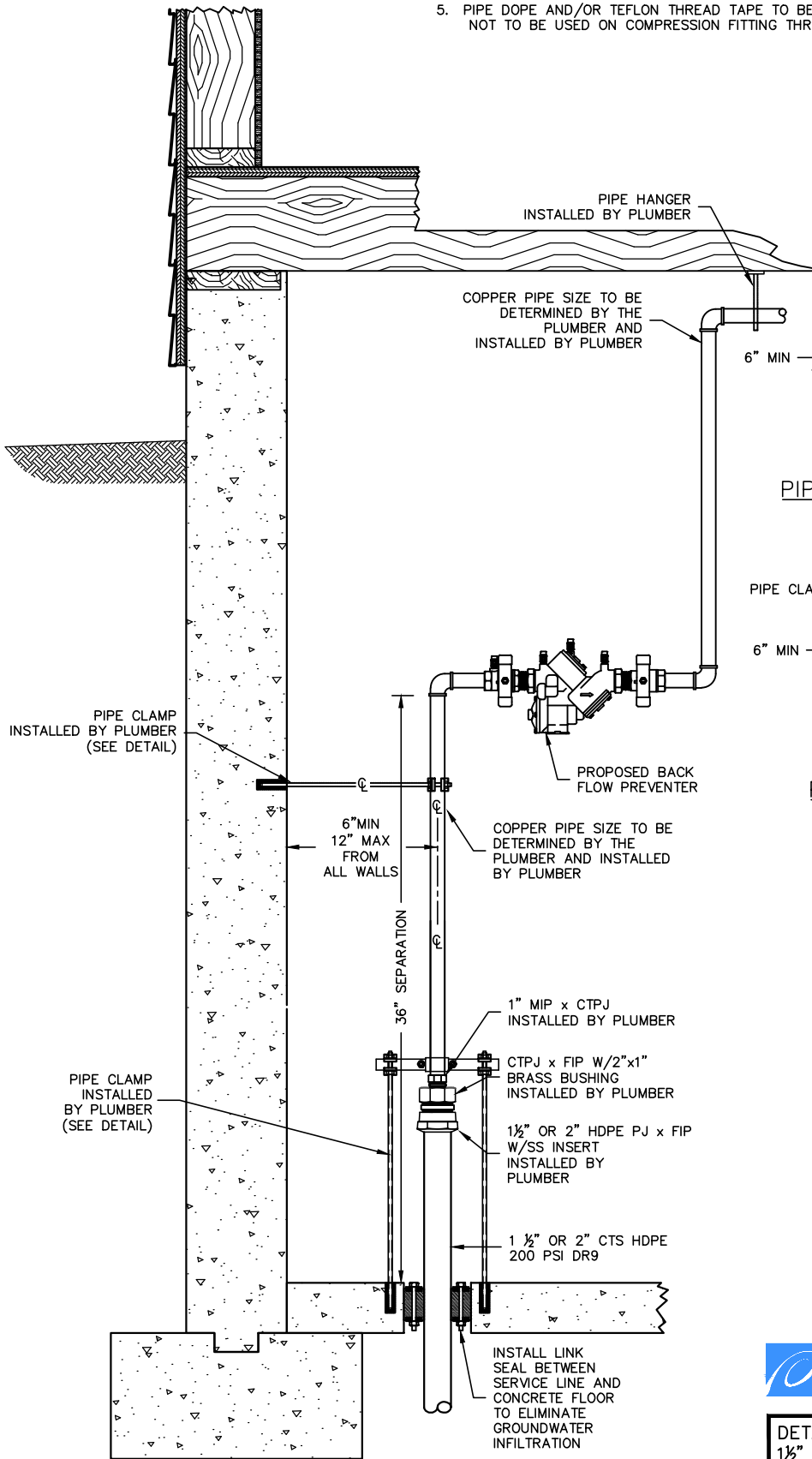

PIPE CLAMP (FLOOR)
NTS

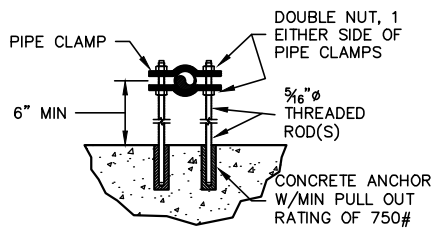

PIPE CLAMP (WALL)
NTS



DETAIL F04
 1½" & 2" HDPE FIRE SERVICE
 CONNECTION THROUGH FLOOR
 INSTALLATION
 PENNICHUCK WATER WORKS, INC.
 REV: 02-20-2026 SCALE: NTS

NOTES:

1. ALL MATERIALS AND INSTALLATION PROCEDURES WILL CONFORM TO P.W.W. SPECIFICATIONS.
2. INSTALLATION UNDER FOOTING OR THROUGH FOUNDATION WALL AT OWNER'S OPTION.
3. OWNER MUST PROVIDE A CLEAN, DRY ACCESSIBLE AND WARM (CONTINUALLY ABOVE 45°F) LOCATION FOR THE BSCK FLOW PREVENTER.
4. SERVICE LINE FROM STREET SIZE & MATERIALS TO BE APPROVED BY P.W.W.
5. PIPE DOPE AND/OR TEFLON THREAD TAPE TO BE USED ON ALL FIP OR MIP FITTINGS. NOT TO BE USED ON COMPRESSION FITTING THREADS.

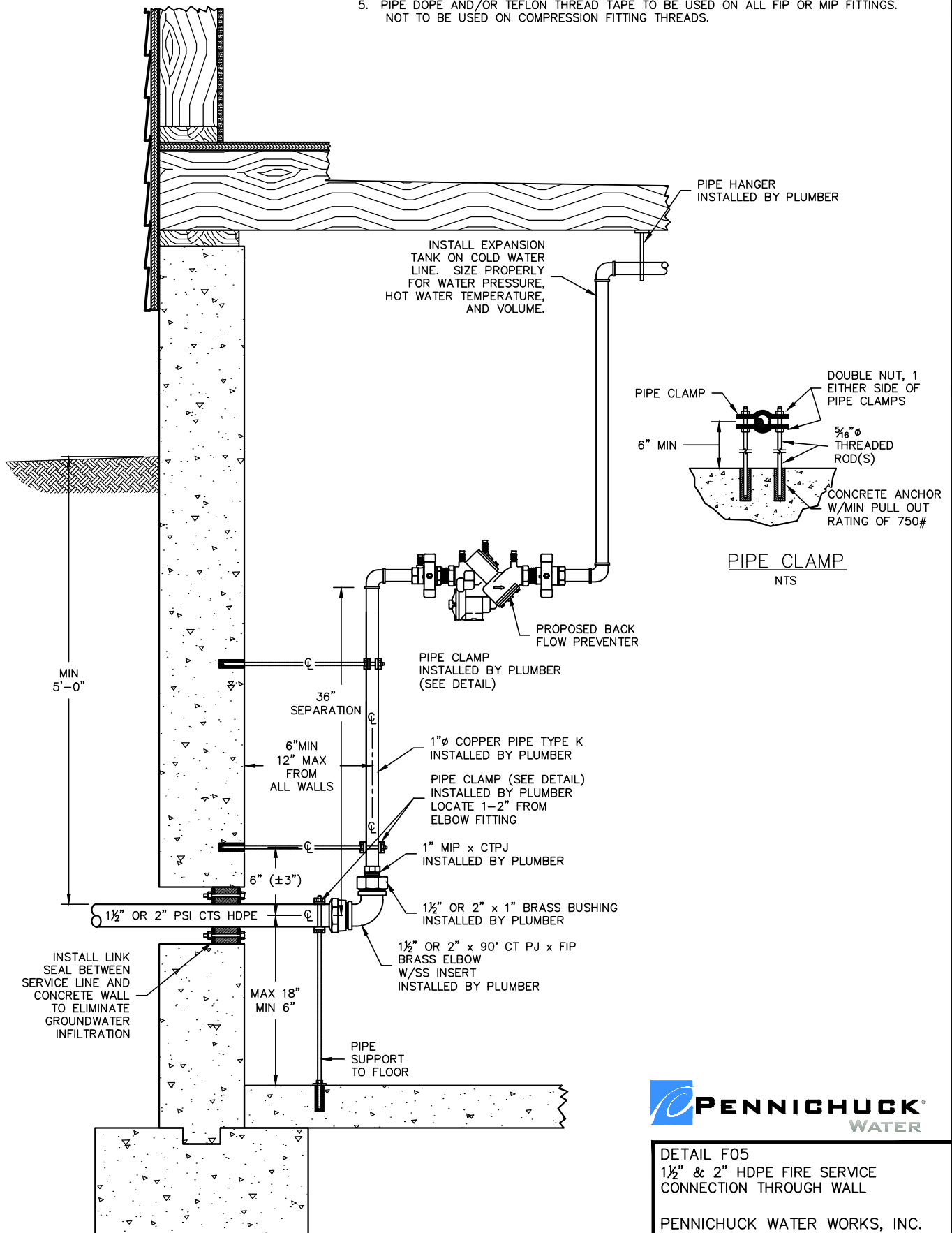

DETAIL F05
 1 1/2" & 2" HDPE FIRE SERVICE
 CONNECTION THROUGH WALL
 PENNICHUCK WATER WORKS, INC.
 DATE: 02-20-2026 SCALE: NTS

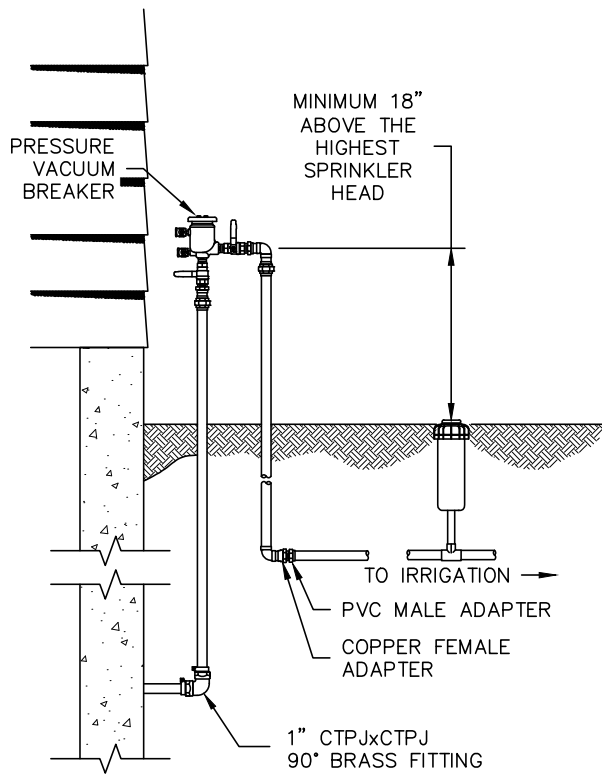

OPTION "A"
THROUGH FOUNDATION WALL

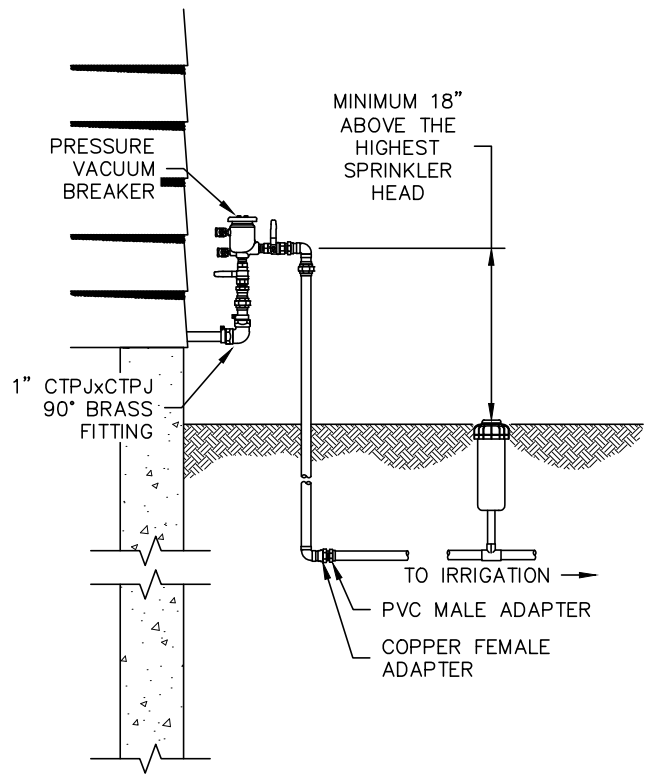

OPTION "B"
THROUGH HOUSE WALL



DETAIL L01
1" IRRIGATION SETUP OPTIONS

PENNICHUCK WATER WORKS, INC.
REV: 03-18 SCALE: NTS

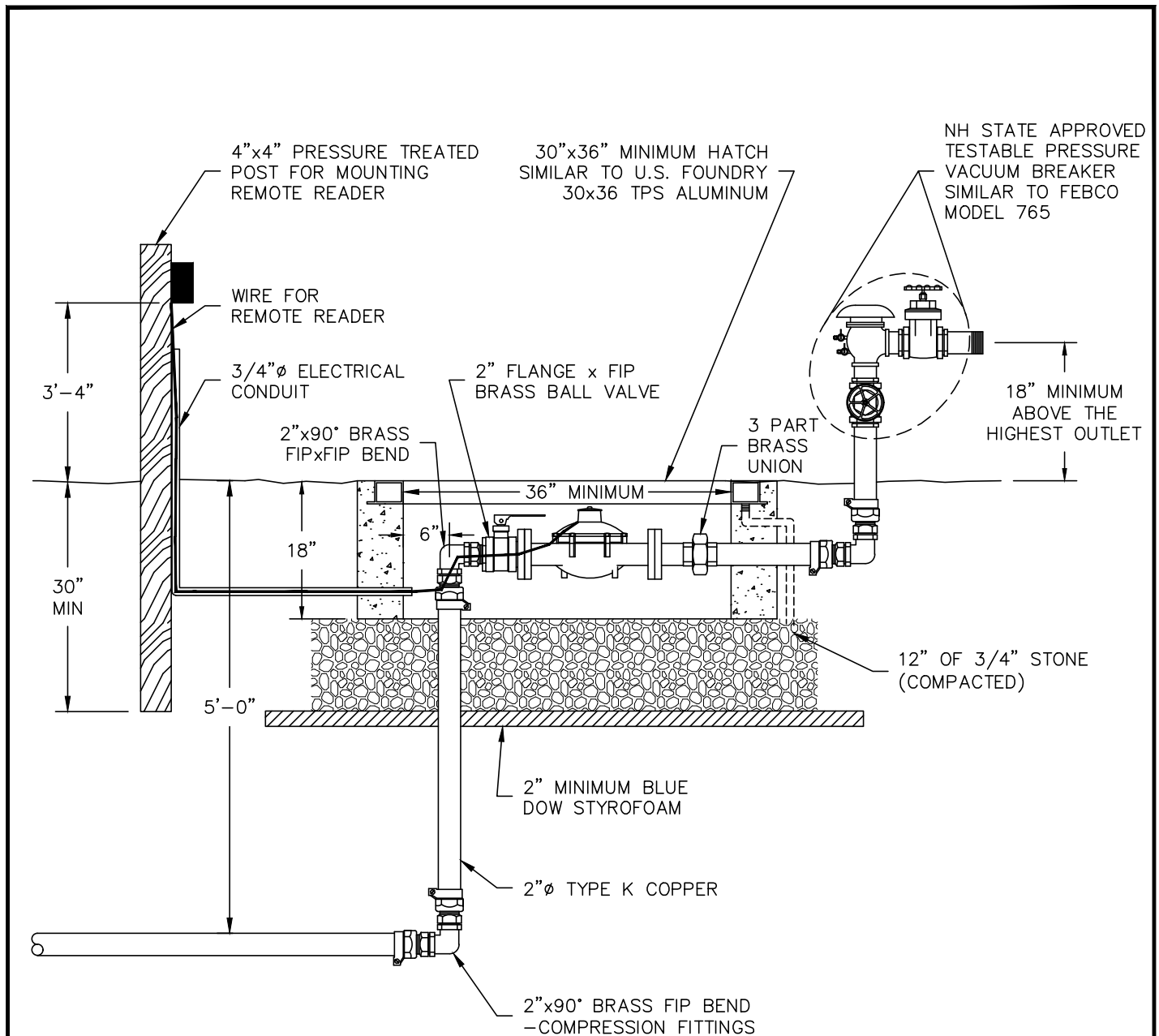

NOTES:

1. ALL MATERIALS AND INSTALLATION PROCEDURES WILL CONFORM TO P.W.W. TECHNICAL SPECIFICATIONS.
2. ALL PIPE SHOULD HAVE A MINIMUM DEPTH OF 5' FROM TOP OF PIPE TO FINISH GRADE.
3. PRV WHEN NECESSARY WILL BE INSTALLED AND PURCHASED BY OWNER OR CONTRACTOR.
4. METER WIRE TO BE 22 AWG 3-STRAND (BLACK/RED/GREEN COLOR CODE) SOLID CORE CABLE AVAILABLE FROM:
ACT SERVICES, INC.
916 PLEASANT STREET
SUITE 3A
NORWOOD, MA 02062
TEL. (781) 255-0978



DETAIL L02
 TYPICAL SHALLOW 2" IRRIGATION
 METER PIT DETAIL
 PENNICHUCK WATER WORKS, INC.
 REV: 03-18 SCALE: NTS

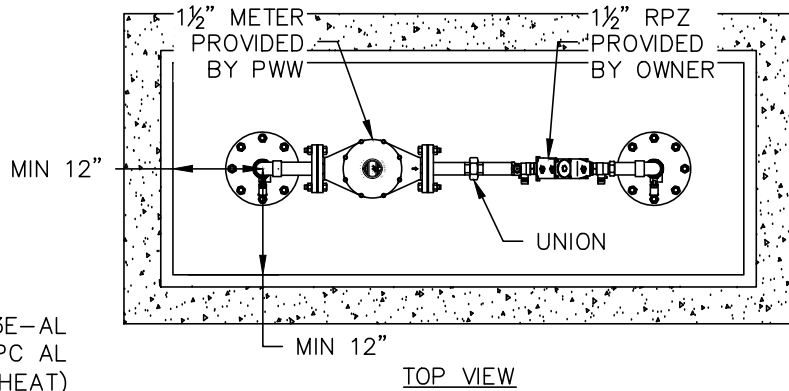

HOT BOX® MODEL LB3E-AL
 (STANDARD 2-PC AL
 ENCLOSURE NO HEAT)
 or EQUIVALENT
 INSIDE DIM:
 70"L x 26"W x 55"H
 SLAB DIM:
 82"L x 38"W
 4" MINIMUM THICKNESS

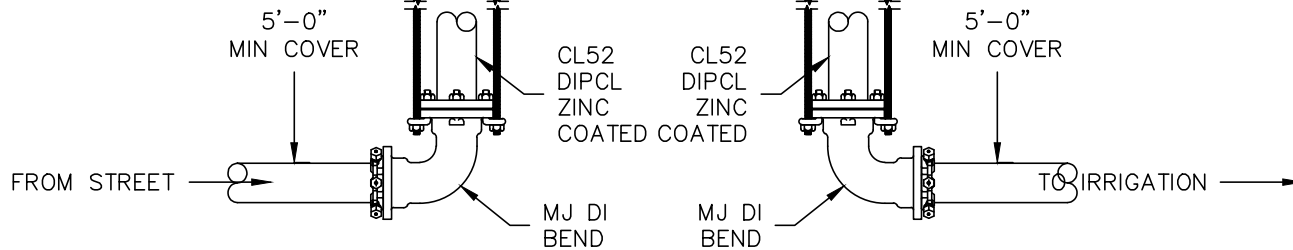
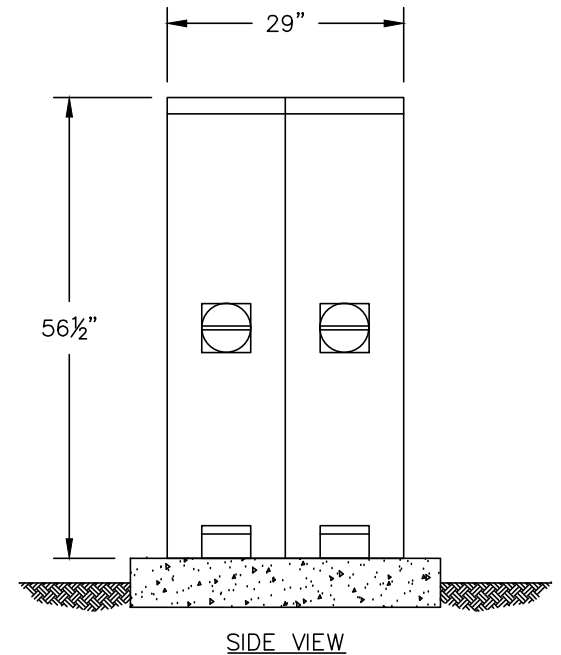
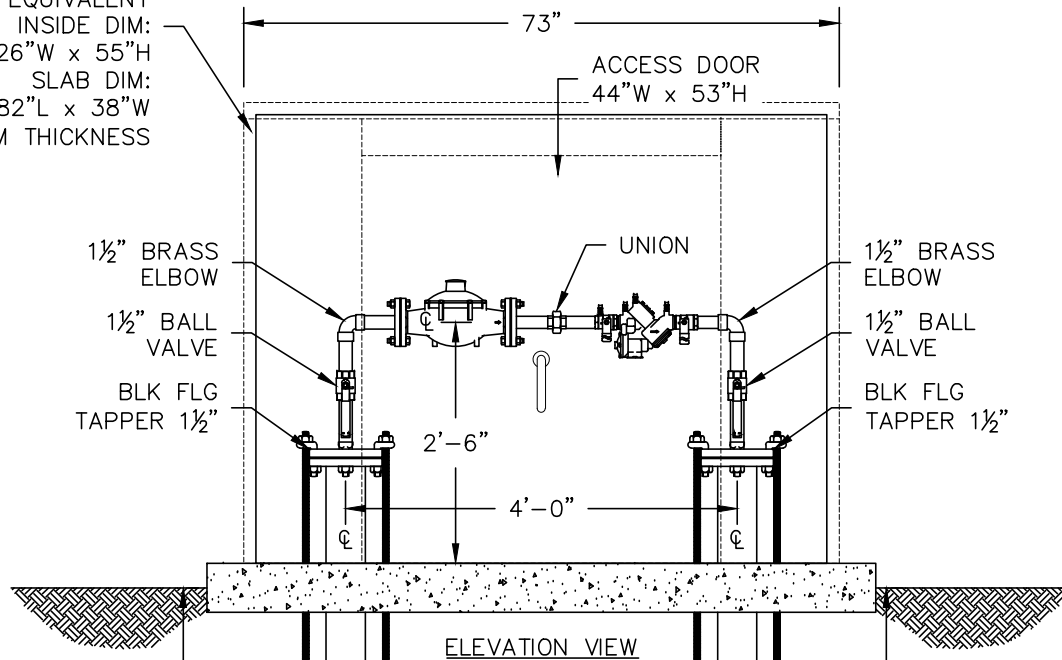

DETAIL L03
 TYPICAL 1 1/2" ABOVE GROUND
 IRRIGATION METER VAULT
 PENNICHUCK WATER WORKS, INC.
 REV: 03-18 SCALE: NTS

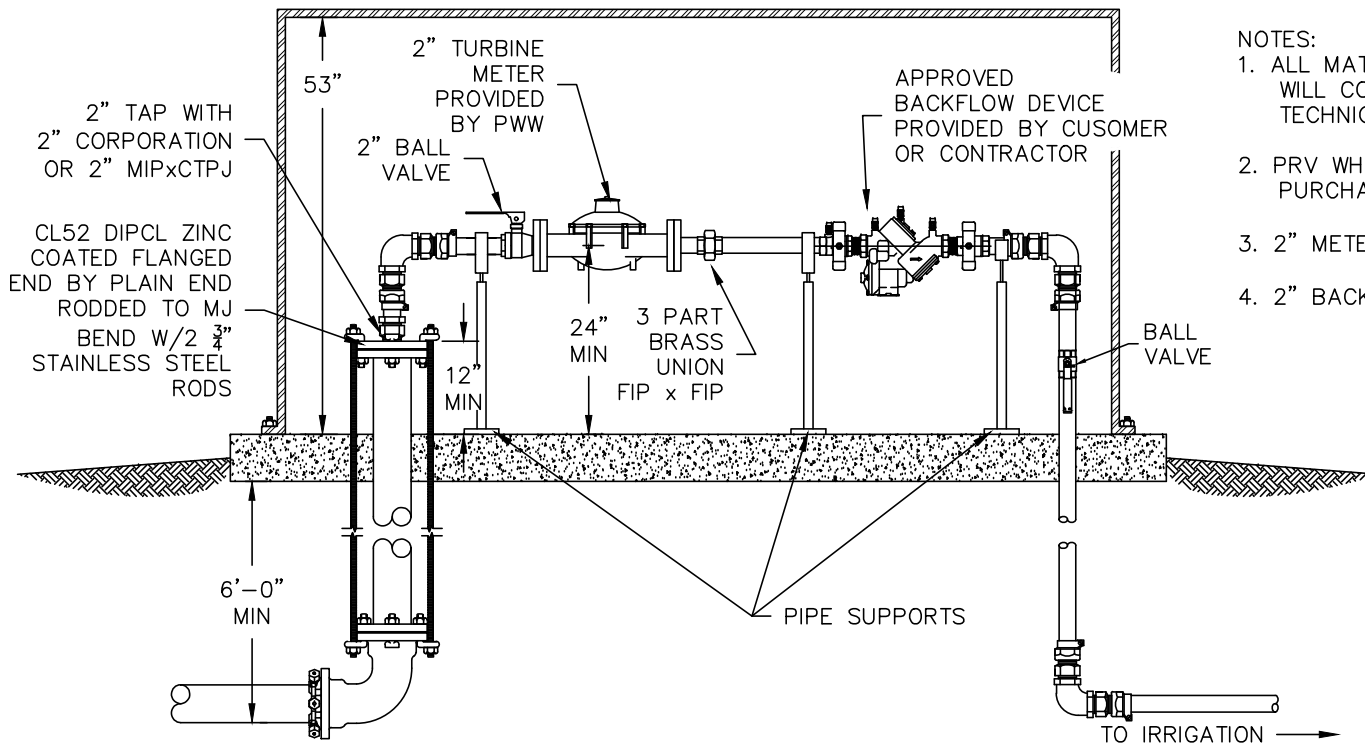
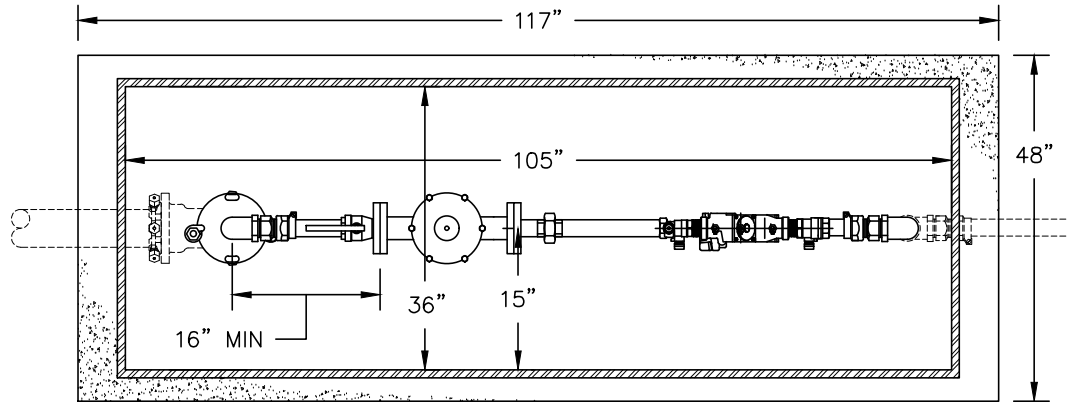

NOTES:

1. ALL MATERIALS AND INSTALLATION PROCEDURES WILL CONFORM TO P.W.W. TECHNICAL SPECIFICATIONS.
2. PRV WHEN NECESSARY WILL BE INSTALLED AND PURCHASED BY OWNER OR CONTRACTOR.
3. 2" METER = 17" LAYING LENGTH.
4. 2" BACKFLOW = 20" LAYING LENGTH. (APPROX)



DETAIL L04
2" ABOVE GROUND IRRIGATION
TYPICAL DETAIL
 PENNICHUCK WATER WORKS, INC.
 REV: 03-18 SCALE: NTS

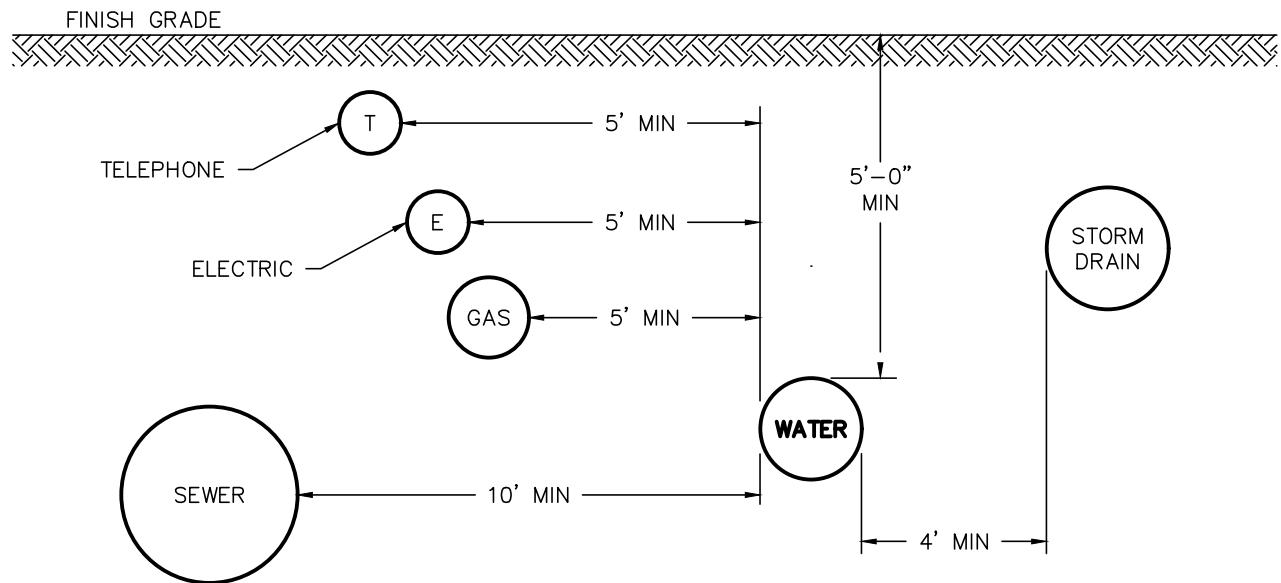

NOTES:

1. ALL MATERIALS AND INSTALLATION PROCEDURES WILL CONFORM TO P.W.W. TECHNICAL SPECIFICATIONS.
2. ALL WATER MAIN SHOULD HAVE A MINIMUM DEPTH OF 5'-0" OF COVER TO FINISH GRADE.
3. SEE DETAIL M02 FOR TRENCH DETAIL.



DETAIL M01
TYPICAL UTILITY SEPARATION
(MAIN) DETAIL
 PENNICHUCK WATER WORKS, INC.
 REV: 03-18 SCALE: NTS

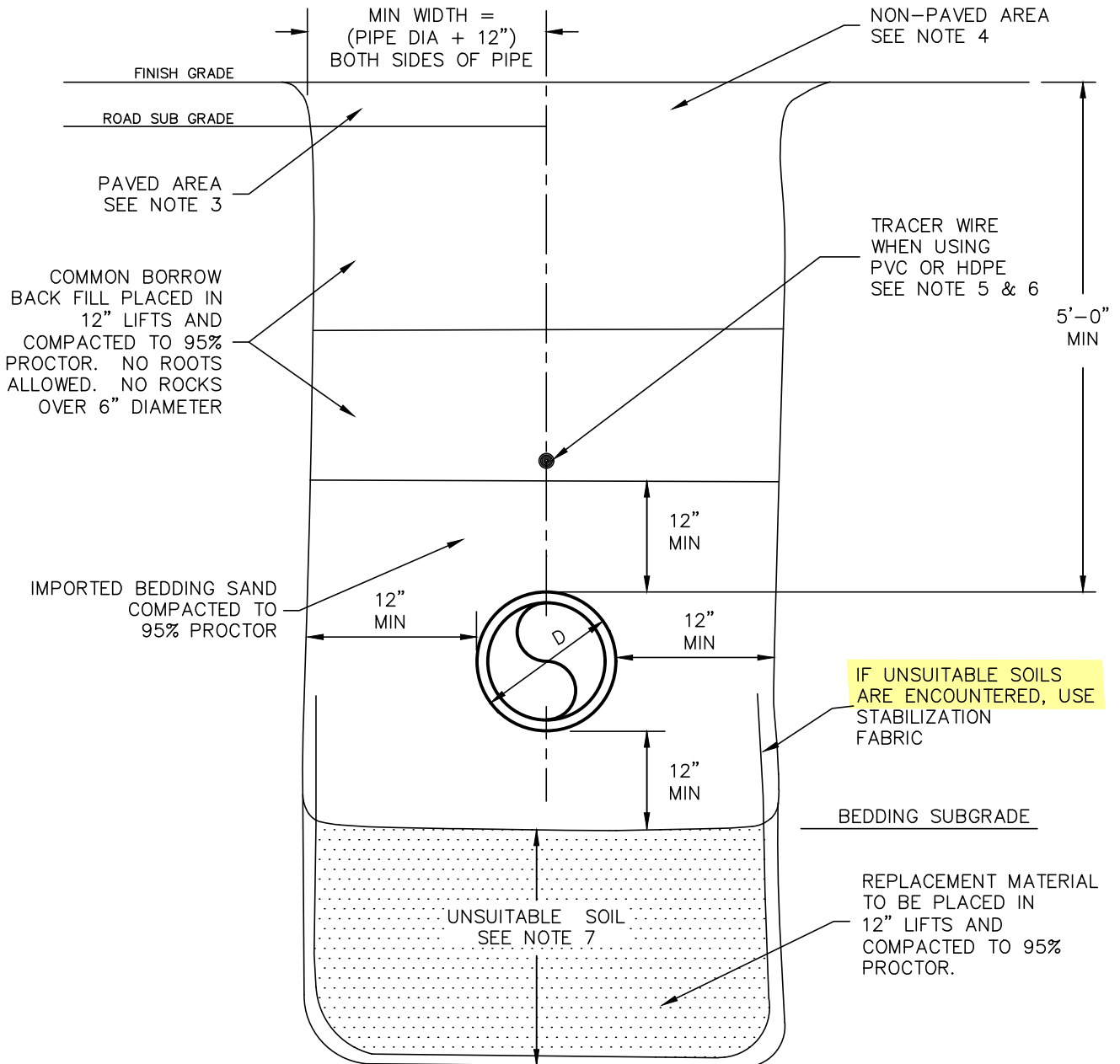

NOTES:

1. ALL MATERIALS AND INSTALLATION PROCEDURES WILL CONFORM TO P.W.W. TECHNICAL SPECIFICATIONS. PENNICHUCK FIELD REPRESENTATIVE SHALL DETERMINE LIMITS OF UNSUITABLE SOILS AND MATERIAL TYPE FOR REPLACEMENT.
2. ALL PIPE SHOULD HAVE A MINIMUM DEPTH OF 5'-0" FROM TOP OF PIPE TO FINISH GRADE.
3. REQUIREMENTS FOR SUBBASE AND BASE MATERIAL TYPE ARE TO BE IN ACCORDANCE WITH LOCAL AUTHORITY HAVING LOCAL JURISDICTION IN PAVED AREAS.
4. REQUIREMENTS FOR GRAVEL, LOAM AND/OR SEED ARE TO BE IN ACCORDANCE WITH LOCAL AUTHORITY HAVING LOCAL JURISDICTION IN NON-PAVED AREAS.
5. USE 10-GAUGE SOLID-CORE COATED TRACER WIRE PER P.W.W. TECHNICAL SPECIFICATIONS.
6. INSTALL 3" WIDE BLUE UNDERGROUND WARNING TAPE.
7. REPLACEMENT MATERIALS FOR UNSUITABLE SOILS ABOVE BEDDING SUBGRADE AND BELOW THE ROAD GRAVELS, SHALL BE EITHER THE BEDDING SAND OR CLEAN COMMON BORROW AS DETAILED.
8. REPLACEMENT MATERIALS FOR UNSUITABLE SOILS BELOW BEDDING SUBGRADE SHALL BE EITHER 1 1/2" CRUSHED STONE OR NHDOT 304.2 GRAVEL, AS DETERMINED BY PWW.

ITEM REVISED IN 2026



DETAIL M02
 TYPICAL TRENCH DETAIL

PENNICHUCK WATER WORKS, INC.
 REV: 02-20-2026 SCALE: NTS

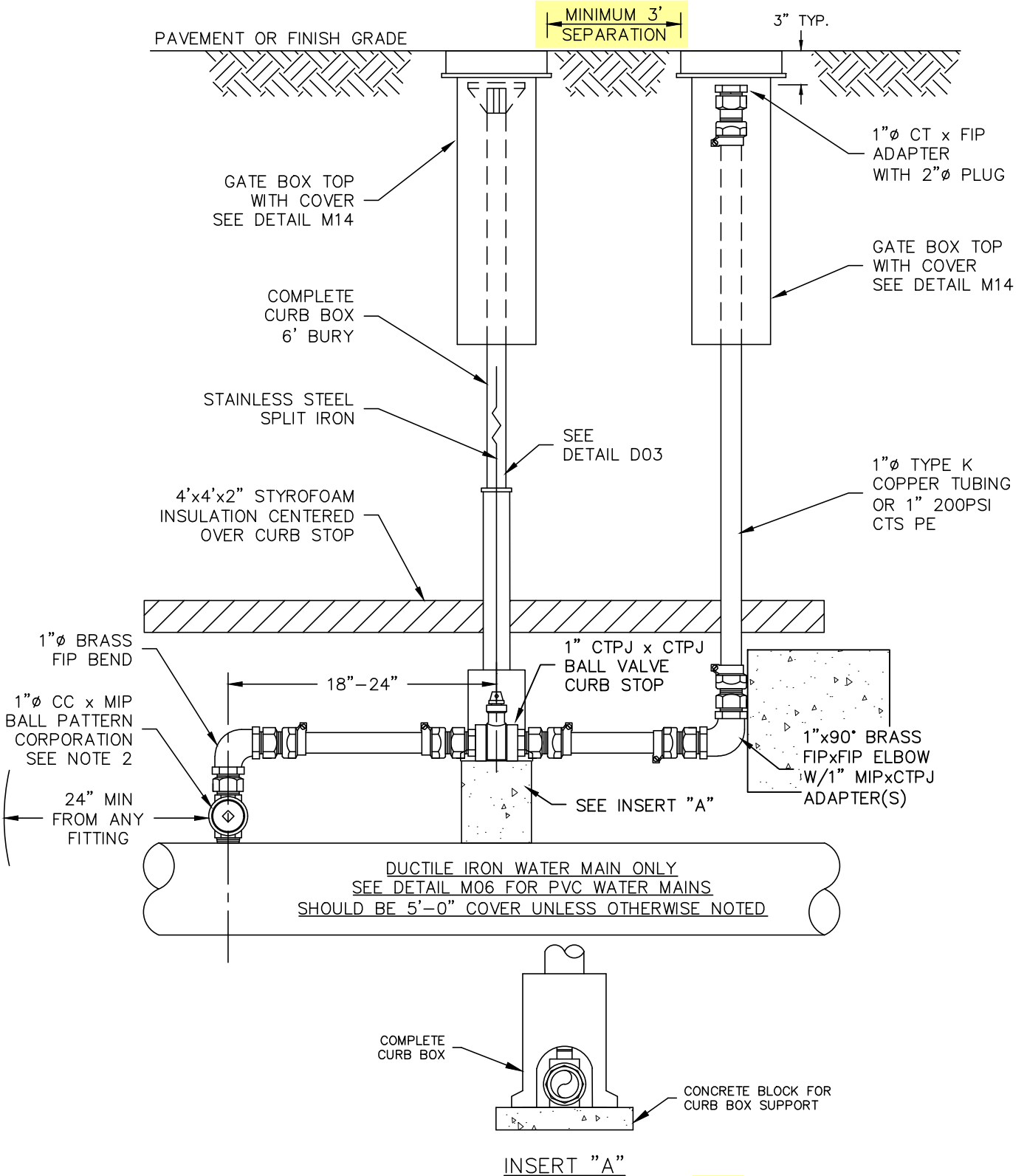

ITEM REVISED IN 2026



NOTES:

1. ALL MATERIALS AND INSTALLATION PROCEDURES WILL CONFORM TO P.W.W. TECHNICAL SPECIFICATIONS.
2. WATER MAIN MAY BE DIRECT TAPPED WHEN IT IS 6" OR LARGER DUCTILE IRON.
3. SEE DETAIL M06 FOR INSTALLATION ON PVC WATER MAINS.

DETAIL M03
 TYPICAL 1" RELEASE VALVE
 INSTALLATION ON DUCTILE IRON
 PENNICHUCK WATER WORKS, INC.
 REV: 02-20-2026 SCALE: NTS

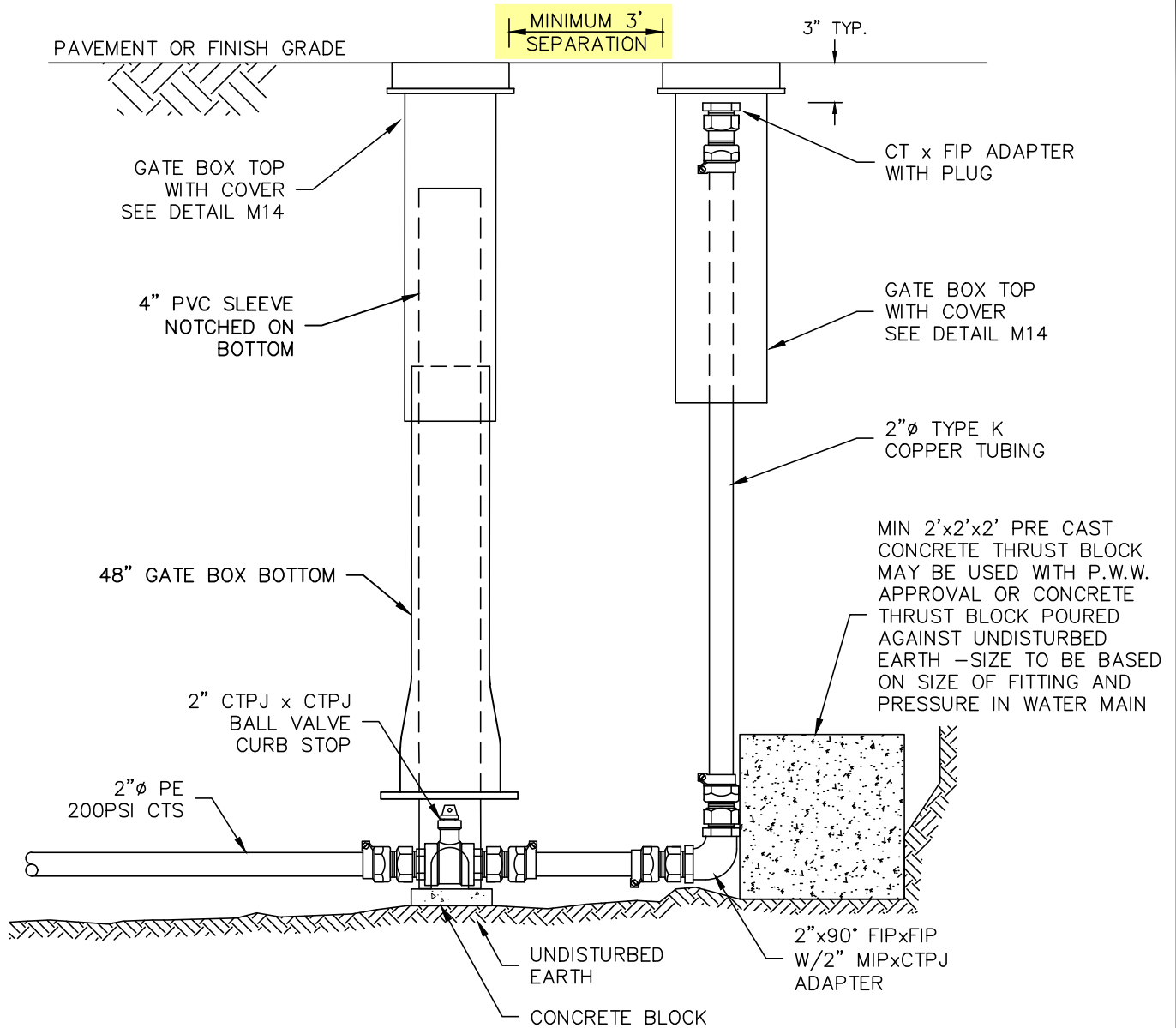

ITEM REVISED IN 2026



NOTES:

1. ALL MATERIALS AND INSTALLATION PROCEDURES WILL CONFORM TO P.W.W. TECHNICAL SPECIFICATIONS.

DETAIL M04
 TYPICAL 2" RELEASE VALVE
 INSTALLATION ON END OF 2" MAIN
 PENNICHUCK WATER WORKS, INC.
 REV: 02-20-2026 SCALE: NTS

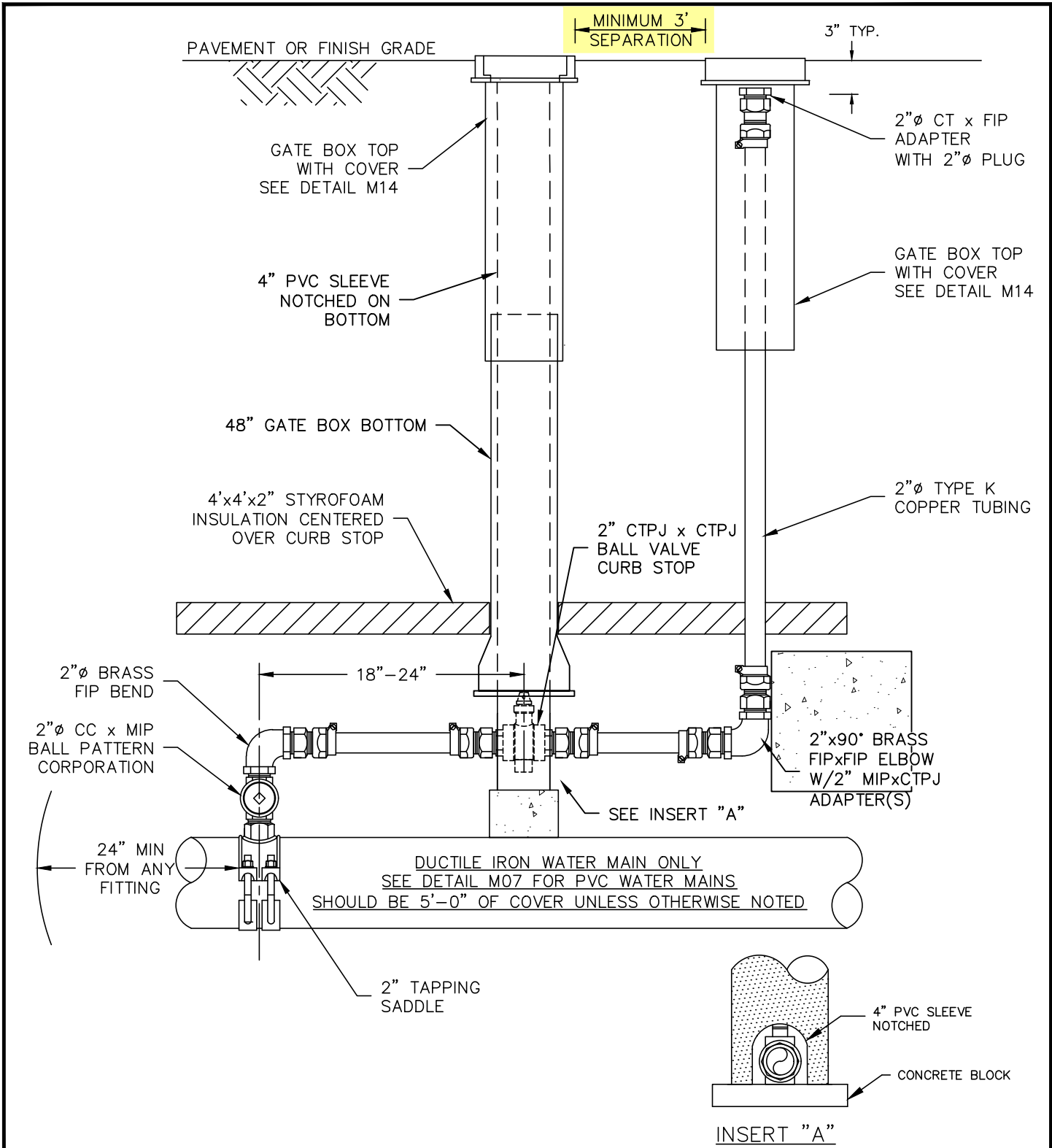

NOTES:

1. ALL MATERIALS AND INSTALLATION PROCEDURES WILL CONFORM TO P.W.W. TECHNICAL SPECIFICATIONS.
2. WATER MAIN MAY BE DIRECT TAPPED WHEN IT IS 16" OR LARGER DUCTILE IRON.
3. SEE DETAIL M07 FOR INSTALLATION ON PVC WATER MAINS.

ITEM REVISED IN 2026

DETAIL M05
 TYPICAL 2" RELEASE VALVE
 INSTALLATION ON DUCTILE IRON
 PENNICHUCK WATER WORKS, INC.
 REV: 02-20-2026 SCALE: NTS

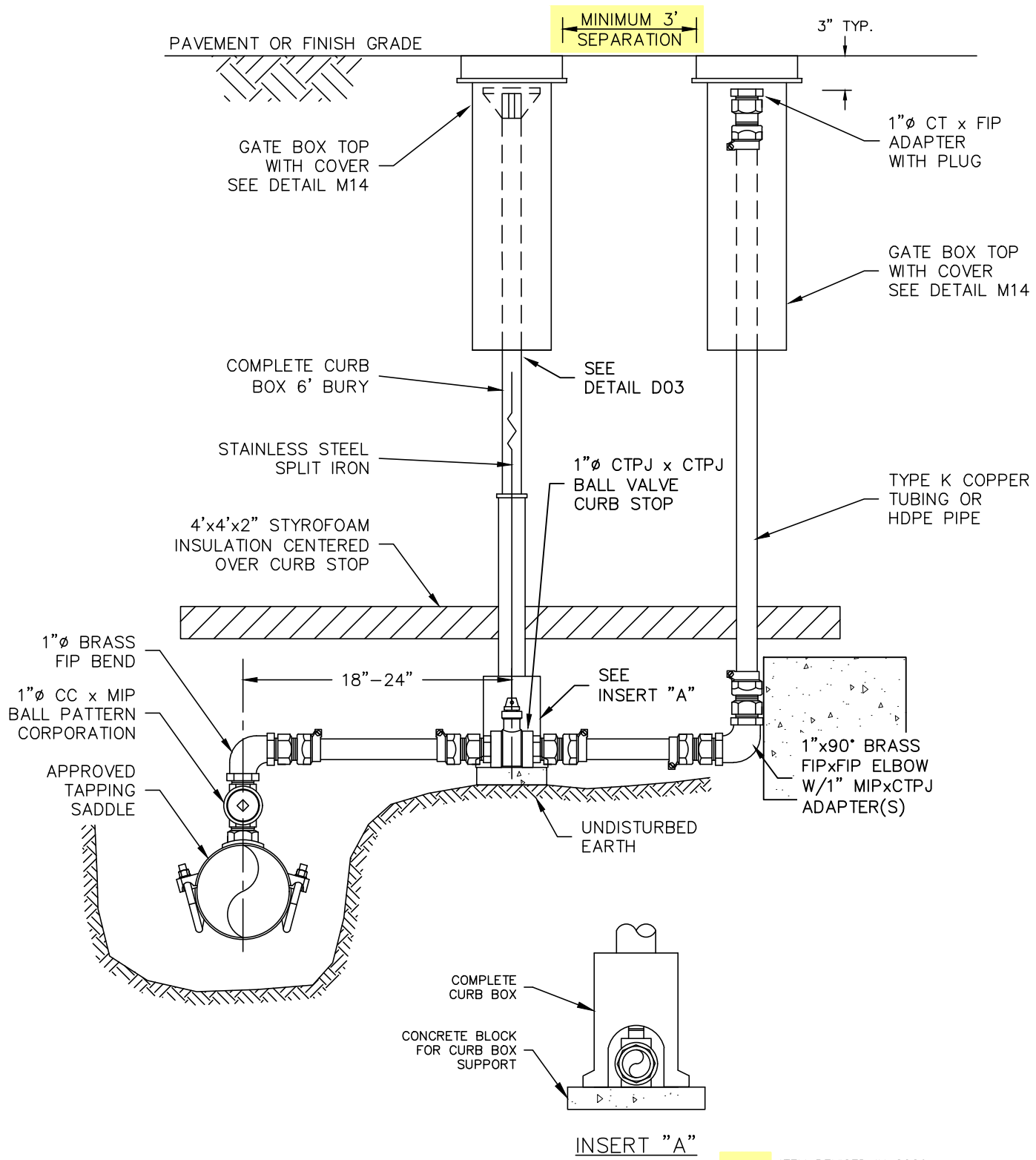

NOTES:

1. ALL MATERIALS AND INSTALLATION PROCEDURES WILL CONFORM TO P.W.W. TECHNICAL SPECIFICATIONS.

ITEM REVISED IN 2026



DETAIL M06
 TYPICAL 1" RELEASE VALVE
 INSTALLATION ON PVC
 PENNICHUCK WATER WORKS, INC.
 REV: 02-20-2026 SCALE: NTS

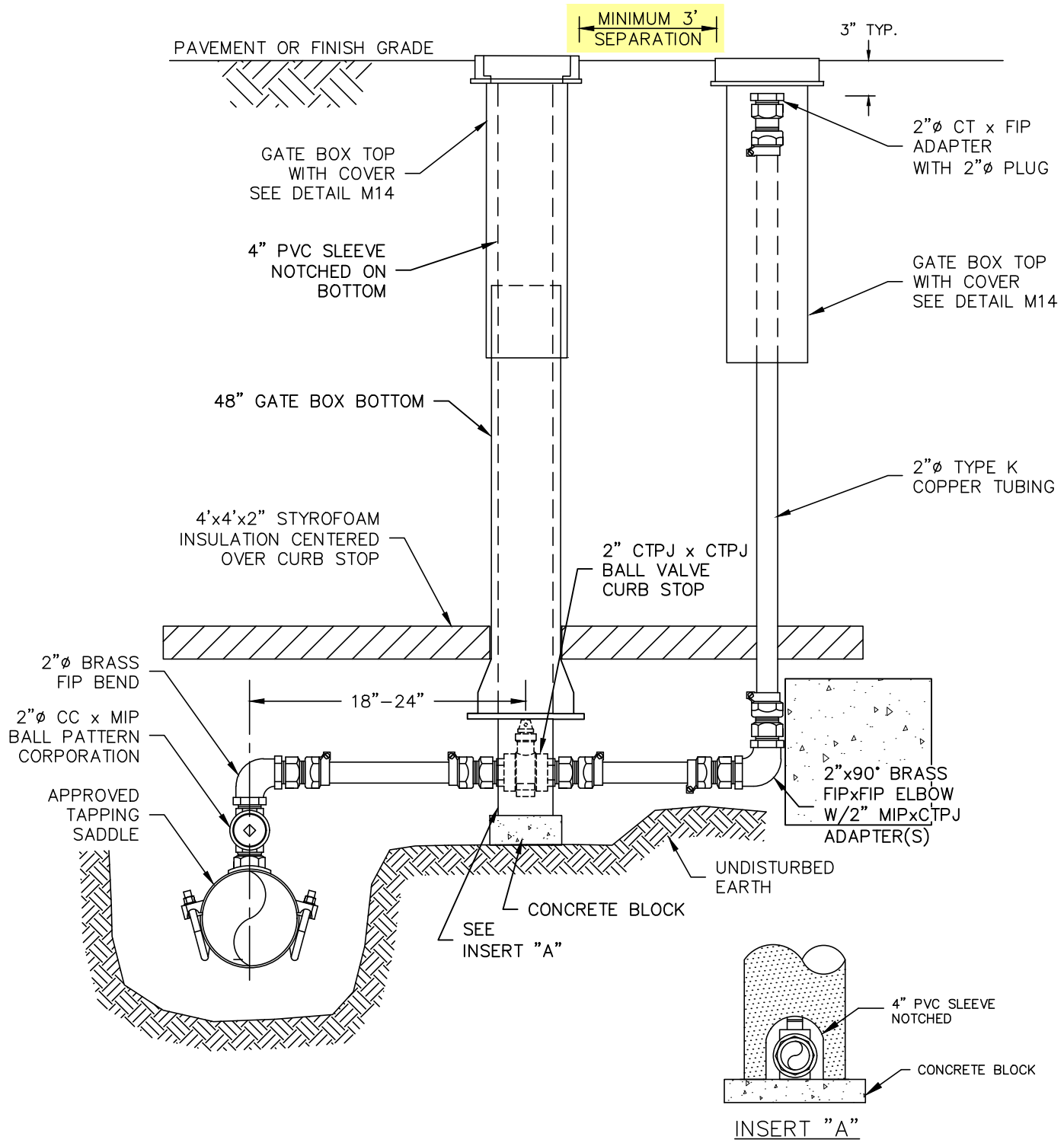

NOTES:

1. ALL MATERIALS AND INSTALLATION PROCEDURES WILL CONFORM TO P.W.W. TECHNICAL SPECIFICATIONS.

ITEM REVISED IN 2026



DETAIL M07
 TYPICAL 2" RELEASE VALVE
 INSTALLATION ON PVC
 PENNICHUCK WATER WORKS, INC.
 REV: 02-20-2026 SCALE: NTS

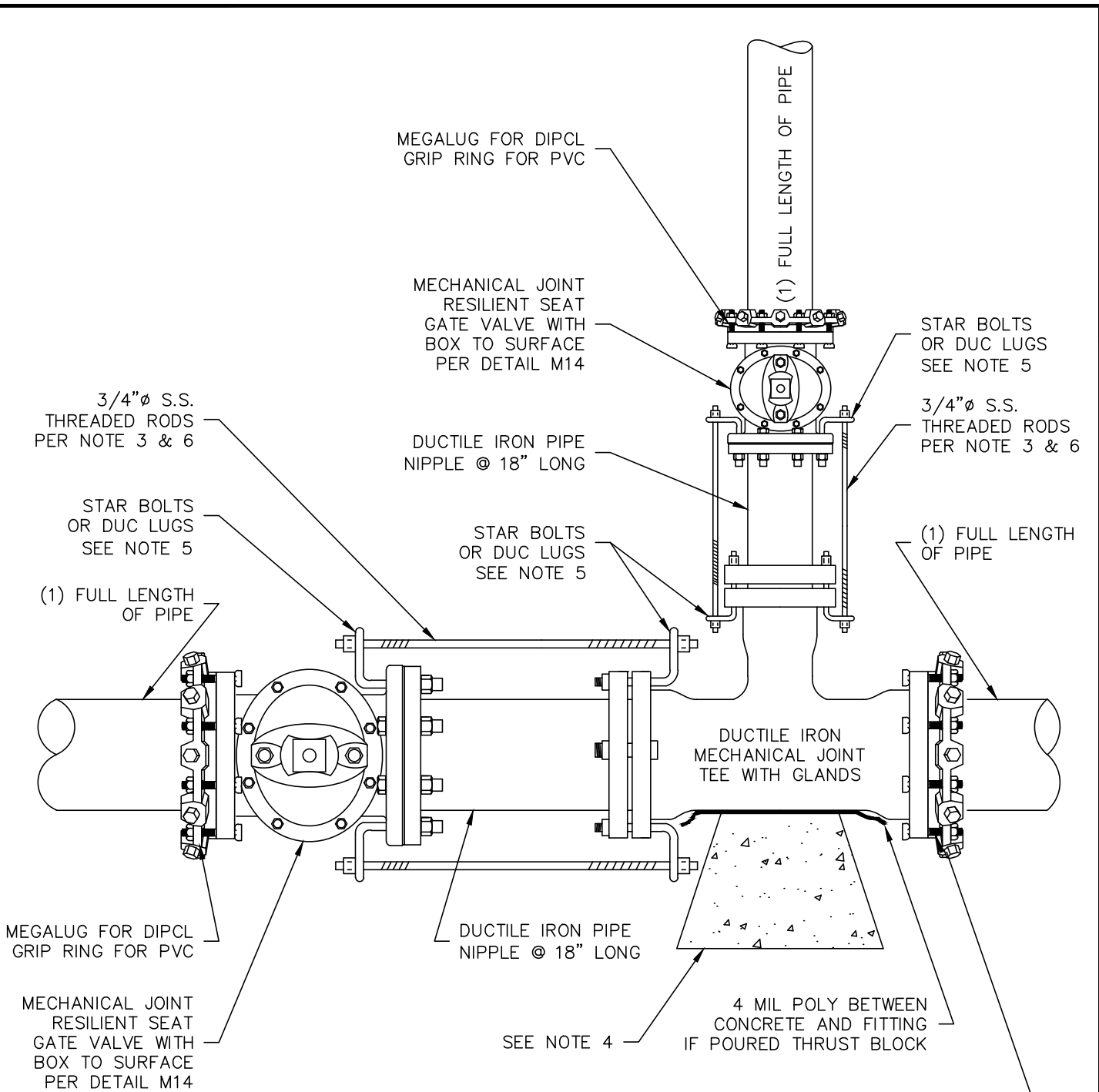

NOTES:

1. ALL MATERIAL AND INSTALLATION PROCEDURES WILL CONFORM TO P.W.W. TECHNICAL SPECIFICATIONS.
2. ALL PIPE SHOULD HAVE A MINIMUM DEPTH 5'-0" FROM TOP OF PIPE TO FINISH GRADE.
3. 3/4" S.S. RODS SHALL BE USED IN CONJUNCTION WITH REQUIRED S.S. NUTS. RODS ARE TO BE ATTACHED TO FITTINGS WITH EITHER STAR BOLTS OR DUC LUGS.
 10" FITTING OR SMALLER = (2) 3/4" S.S. RODS & ASSOC. HARDWARE.
 12" FITTING OR LARGER = (4) 3/4" S.S. RODS & ASSOC. HARDWARE.
4. MIN 2'x2'x3' PRE CAST CONCRETE THRUST BLOCK MAY BE USED WITH P.W.W. APPROVAL OR CONCRETE THRUST BLOCK POURED AGAINST UNDISTURBED EARTH - SIZE TO BE BASED ON SIZE OF FITTING AND PRESSURE IN WATER MAIN. SEE DETAIL M10.
5. SEE PWW TECHNICAL SPECIFICATION SECTION 01600.C.16.F
6. ALL MECHANICAL JOINT FITTINGS SEPARATED BY PIPE LENGTH OF 10 FEET OR LESS MUST BE RODDED PER PWW TECHNICAL SPECIFICATION SECTION 01600E.2.F IF SEPARATION IS MORE THAN 10 FEET SUBSTITUTE MEGALUGS (OR GRIP RINGS) IN LIEU OF THREADED RODS.



DETAIL M08
 TYPICAL TEE INSTALLATION
 PENNICHUCK WATER WORKS, INC.
 REV: 11-1-2021 SCALE: NTS

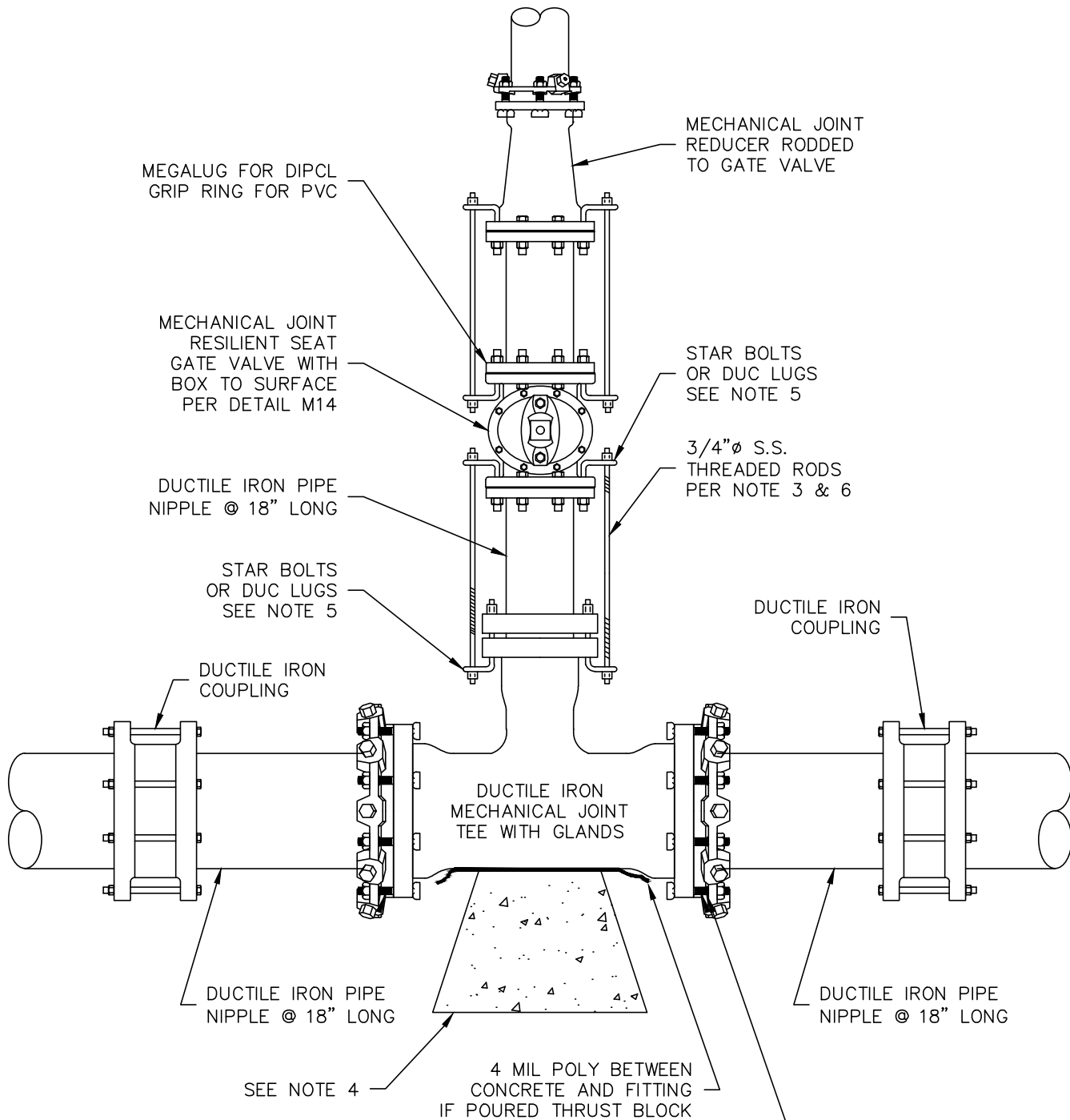

NOTES:

1. ALL MATERIAL AND INSTALLATION PROCEDURES WILL CONFORM TO P.W.W. TECHNICAL SPECIFICATIONS.
2. ALL PIPE SHOULD HAVE A MINIMUM DEPTH OF 5' FROM TOP OF PIPE TO FINISH GRADE.
3. 3/4" ϕ S.S. RODS SHALL BE USED IN CONJUNCTION WITH REQUIRED S.S. NUTS. RODS ARE TO BE ATTACHED TO FITTINGS WITH EITHER STAR BOLTS OR DUC LUGS.
10" FITTING OR SMALLER = (2) 3/4" ϕ S.S. RODS & ASSOC. HARDWARE.
12" FITTING OR LARGER = (4) 3/4" ϕ S.S. RODS & ASSOC. HARDWARE.
4. MIN 2'x2'x3' PRE CAST CONCRETE THRUST BLOCK MAY BE USED WITH P.W.W. APPROVAL OR CONCRETE THRUST BLOCK POURED AGAINST UNDISTURBED EARTH - SIZE TO BE BASED ON SIZE OF FITTING AND PRESSURE IN WATER MAIN. SEE DETAIL M10.
5. SEE PWW TECHNICAL SPECIFICATION SECTION 01600.C.16.F
6. ALL MECHANICAL JOINT FITTINGS SEPARATED BY PIPE LENGTH OF 10 FEET OR LESS MUST BE RODDED PER PWW TECHNICAL SPECIFICATION SECTION 01600E.2.F IF SEPARATION IS MORE THAN 10 FEET SUBSTITUTE MEGALUGS (OR GRIP RINGS) IN LIEU OF THREADED RODS.



DETAIL M09
TYPICAL TEE INSTALLATION
ON EXISTING MAIN
 PENNICHUCK WATER WORKS, INC.
 REV: 11-1-2021 SCALE: NTS

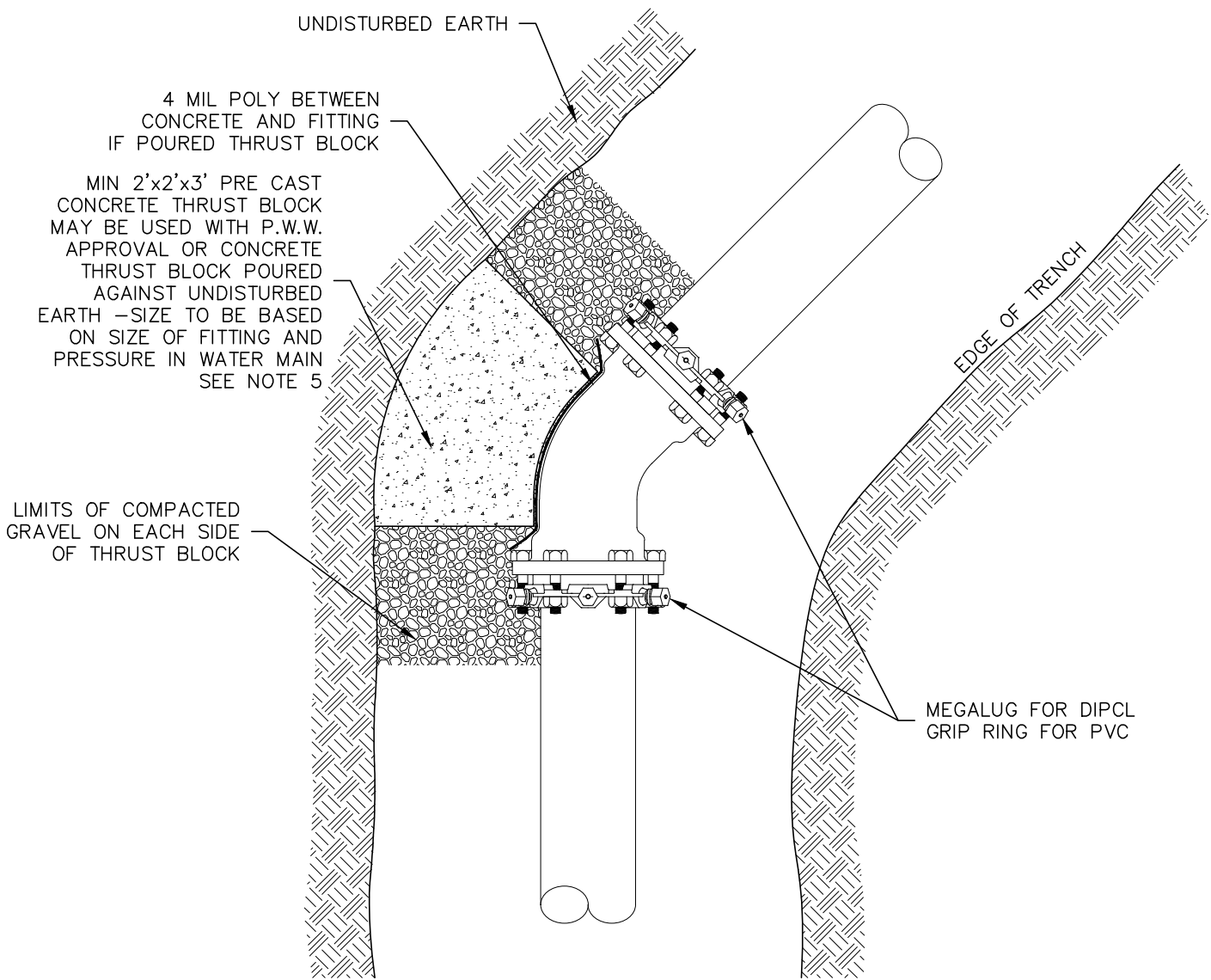

NOTES:

1. ALL MATERIAL AND INSTALLATION PROCEDURES WILL CONFORM TO P.W.W. TECHNICAL SPECIFICATIONS.
2. ALL PIPE SHOULD HAVE A MINIMUM DEPTH 5'-0" FROM TOP OF PIPE TO FINISH GRADE.
3. 3/4" ϕ S.S. RODS SHALL BE USED IN CONJUNCTION WITH REQUIRED S.S. NUTS. RODS ARE TO BE ATTACHED TO FITTINGS WITH EITHER STAR BOLTS OR DUC LUGS PER SPECIFICATION SECTION 01600C.16.F 10" FITTING OR SMALLER = (2) 3/4" ϕ S.S. RODS & ASSOC. HARDWARE. 12" FITTING OR LARGER = (4) 3/4" ϕ S.S. RODS & ASSOC. HARDWARE.
4. MIN 2'x2'x3' PRE CAST CONCRETE THRUST BLOCK MAY BE USED WITH P.W.W. APPROVAL OR CONCRETE THRUST BLOCK Poured AGAINST UNDISTURBED EARTH - SIZE TO BE BASED ON SIZE OF FITTING AND PRESSURE IN WATER MAIN.
5. VOID BETWEEN PRECAST THRUST BLOCK AND VIRGIN SOIL TO BE FILLED AND CHINKED WITH STONE
6. ALL MECHANICAL JOINT FITTINGS SEPARATED BY PIPE LENGTH OF 10 FEET OR LESS MUST BE RODDED PER PWW TECHNICAL SPECIFICATION SECTION 01600E.2.F IF SEPARATION IS MORE THAN 10 FEET SUBSTITUTE MEGALUGS (OR GRIP RINGS) IN LIEU OF THREADED RODS.



DETAIL M10
 TYPICAL THRUST BLOCK BEHIND
 FITTINGS INSTALLATION
 PENNICHUCK WATER WORKS, INC.
 REV: 11-1-2021 SCALE: NTS

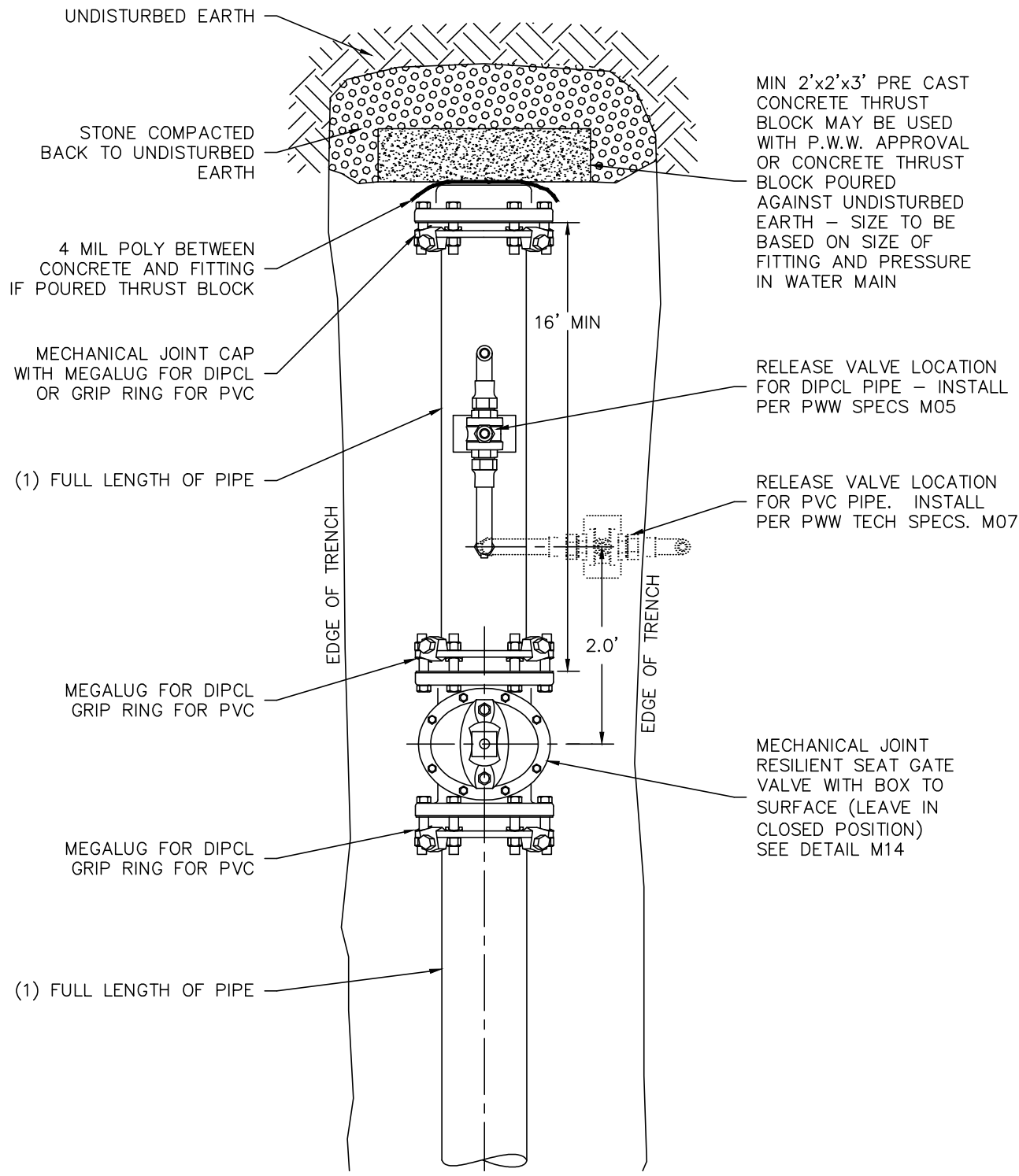

NOTES:

1. ALL MATERIALS AND INSTALLATION PROCEDURES WILL CONFORM TO P.W.W. TECHNICAL SPECIFICATIONS.
2. ALL PIPE SHOULD HAVE A MINIMUM DEPTH OF 5' FROM TOP OF PIPE TO FINISH GRADE.



DETAIL M11
 TYPICAL END OF MAIN W/GATE
 VALVE INSTALLATION
 PENNICHUCK WATER WORKS, INC.
 REV: 03-18 SCALE: NTS

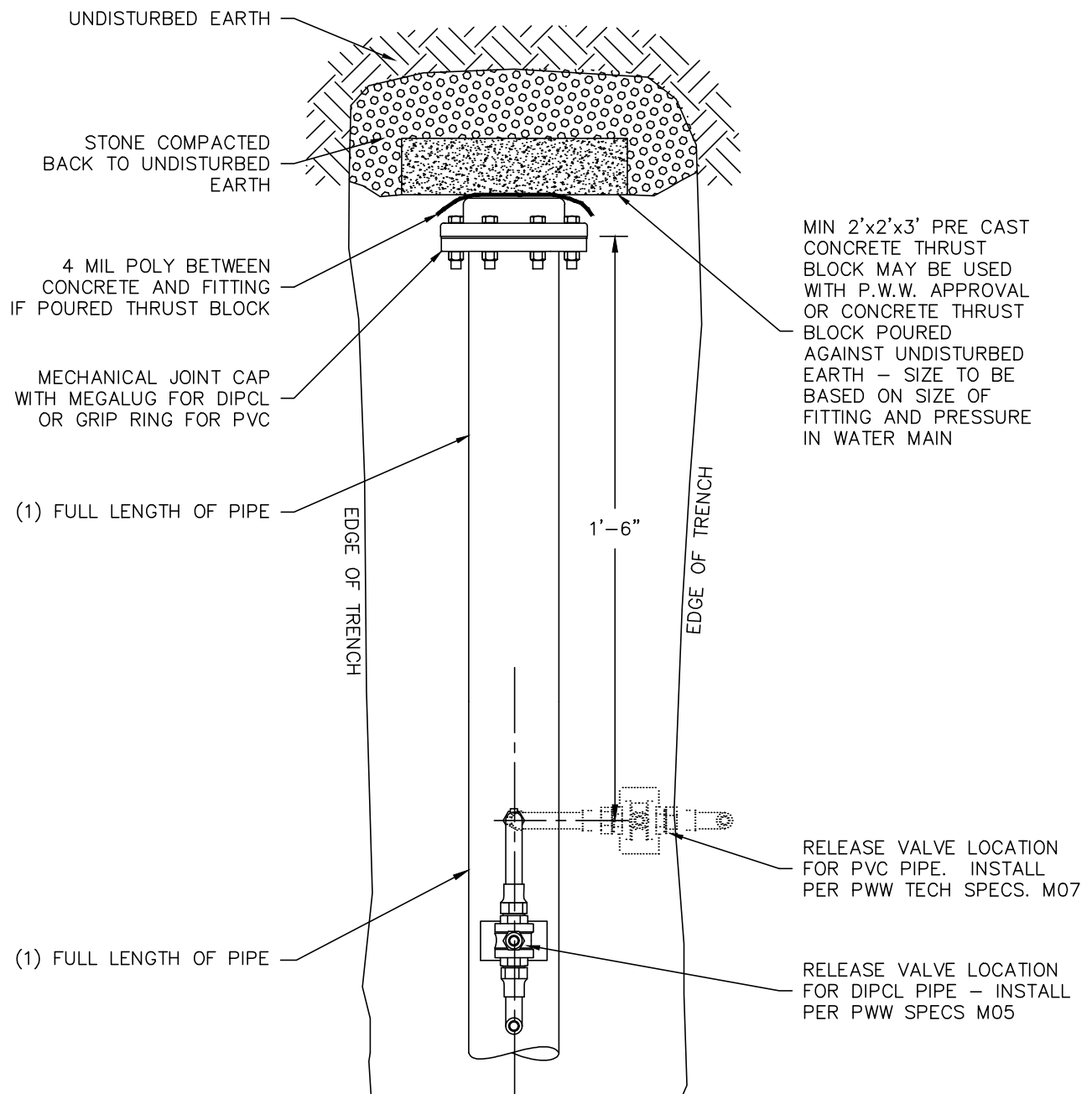

NOTES:

1. ALL MATERIALS AND INSTALLATION PROCEDURES WILL CONFORM TO P.W.W. TECHNICAL SPECIFICATIONS.
2. ALL PIPE SHOULD HAVE A MINIMUM DEPTH OF 5' FROM TOP OF PIPE TO FINISH GRADE.



DETAIL M12
 TYPICAL END OF MAIN W/O
 GATE VALVE INSTALLATION
 PENNICHUCK WATER WORKS, INC.
 REV: 03-18 SCALE: NTS

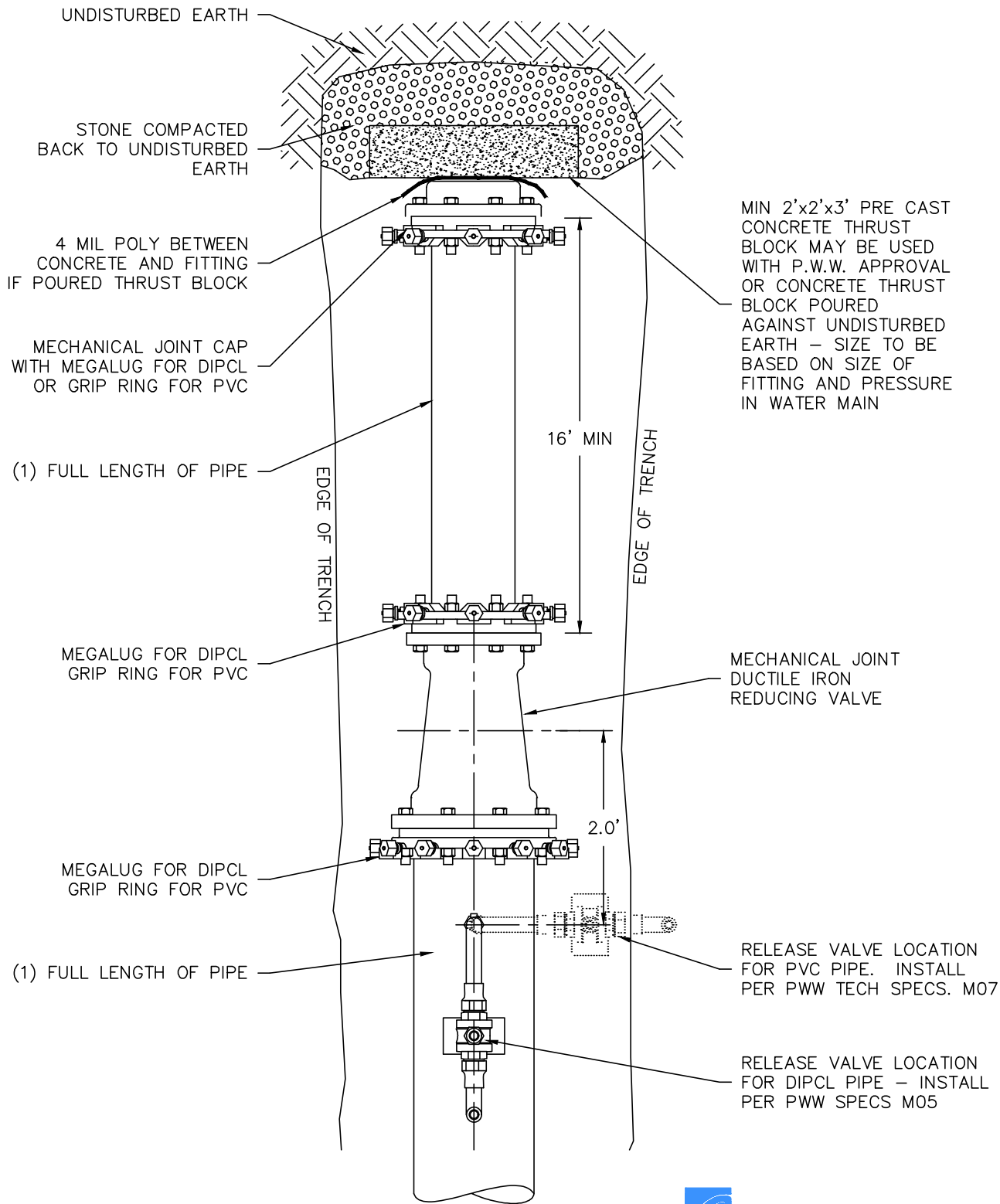

NOTES:

1. ALL MATERIALS AND INSTALLATION PROCEDURES WILL CONFORM TO P.W.W. TECHNICAL SPECIFICATIONS.
2. ALL PIPE SHOULD HAVE A MINIMUM DEPTH OF 5' FROM TOP OF PIPE TO FINISH GRADE.



DETAIL M13
 TYPICAL END OF MAIN W/REDUCER
 INSTALLATION
 PENNICHUCK WATER WORKS, INC.
 REV: 03-18 SCALE: NTS

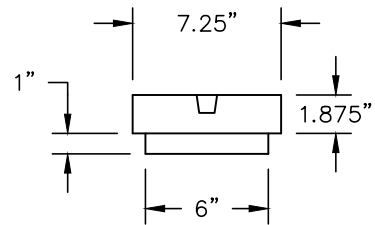
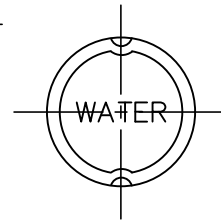
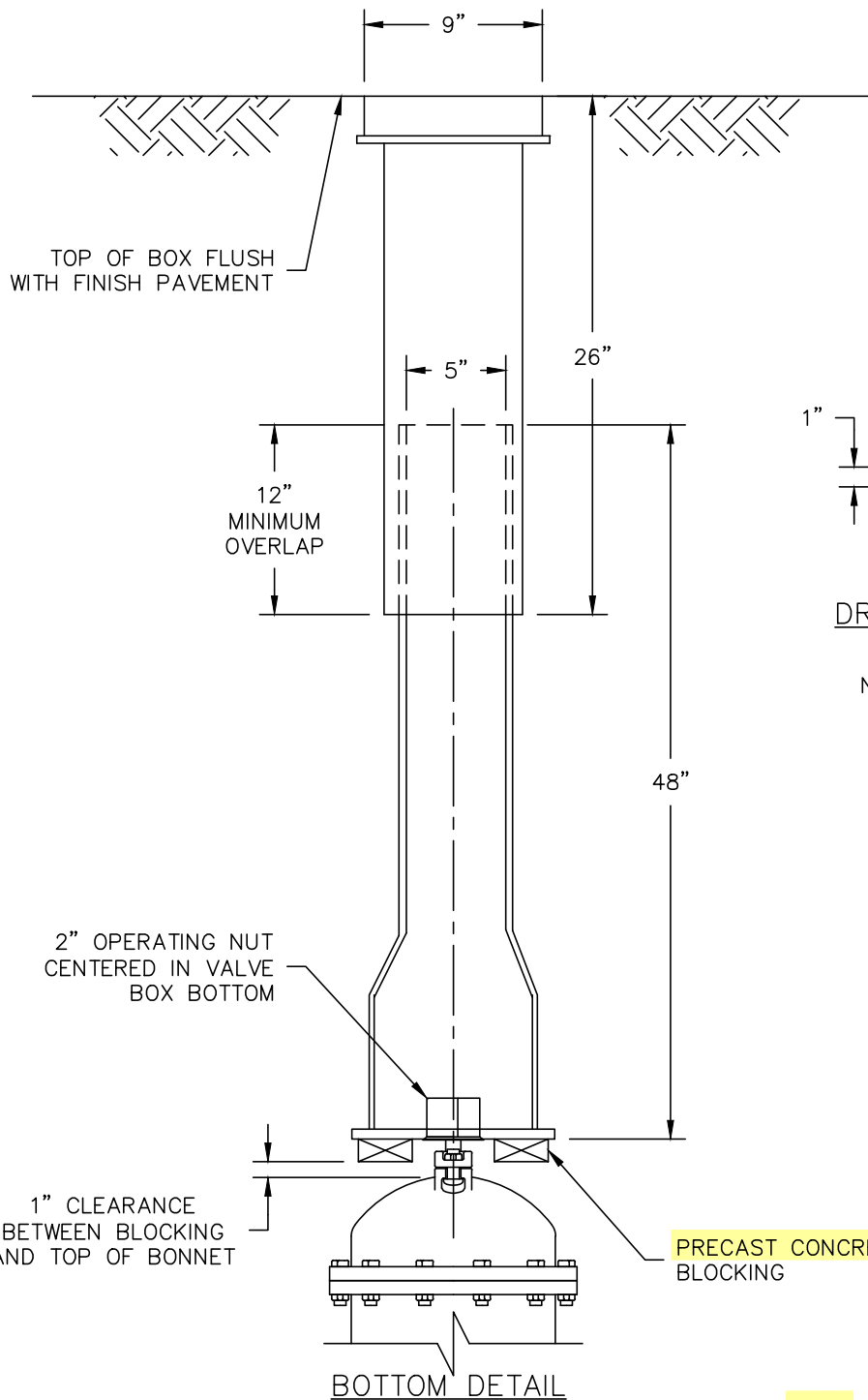

DROP STYLE COVER

NOTE: COVER MUST BE MARKED "WATER"

NOTES:

1. ALL MATERIALS AND INSTALLATION PROCEDURES WILL CONFORM TO P.W.W. TECHNICAL SPECIFICATIONS.

ITEM REVISED IN 2023



DETAIL M14
TYPICAL VALVE BOX DETAIL
 PENNICHUCK WATER WORKS, INC.

REV: 03-15-2023 SCALE: NTS

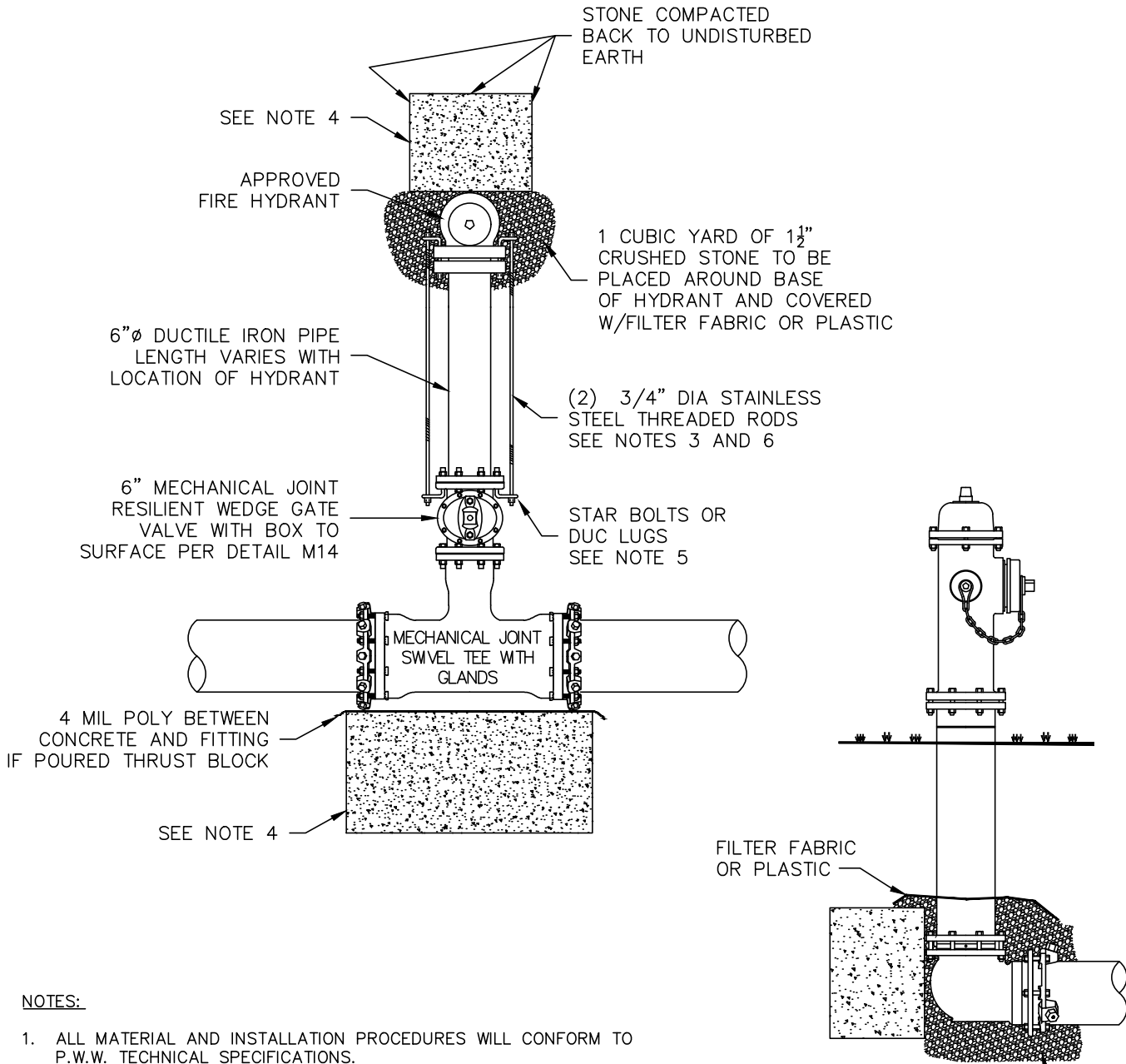

NOTES:

1. ALL MATERIAL AND INSTALLATION PROCEDURES WILL CONFORM TO P.W.W. TECHNICAL SPECIFICATIONS.
2. ALL PIPE SHOULD HAVE A MINIMUM DEPTHS OF 5' FROM TOP OF PIPE TO FINISH GRADE.
3. 3/4"φ S.S. RODS SHALL BE USED IN CONJUNCTION WITH REQUIRED S.S. NUTS. RODS ARE TO BE ATTACHED TO FITTINGS WITH EITHER STAR BOLTS OR DUC LUGS. 10" FITTING OR SMALLER = (2) 3/4"φ S.S. RODS & ASSOC. HARDWARE. 12" FITTING OR LARGER = (4) 3/4"φ S.S. RODS & ASSOC. HARDWARE.
4. MIN 2'x2'x3' PRE CAST CONCRETE THRUST BLOCK MAY BE USED WITH P.W.W. APPROVAL OR CONCRETE THRUST BLOCK POURED AGAINST UNDISTURBED EARTH – SIZE TO BE BASED ON SIZE OF FITTING AND PRESSURE IN WATER MAIN. SEE DETAIL M10.
5. SEE PWW TECHNICAL SPECIFICATION SECTION 01600.C.16.F
6. ALL MECHANICAL JOINT FITTINGS SEPARATED BY PIPE LENGTH OF 10 FEET OR LESS MUST BE RODDED PER PWW TECHNICAL SPECIFICATION SECTION 01600E.2.F IF SEPARATION IS MORE THAN 10 FEET SUBSTITUTE MEGALUGS (OR GRIP RINGS) IN LIEU OF THREADED RODS.

1 CUBIC YARD OF 1 1/2" CRUSHED STONE TO BE PLACED AROUND BASE OF HYDRANT AND COVERED W/FILTER FABRIC OR PLASTIC



DETAIL M15
 TYPICAL HYDRANT INSTALLATION
 PENNICHUCK WATER WORKS, INC.
 REV: 11-1-2021 SCALE: NTS

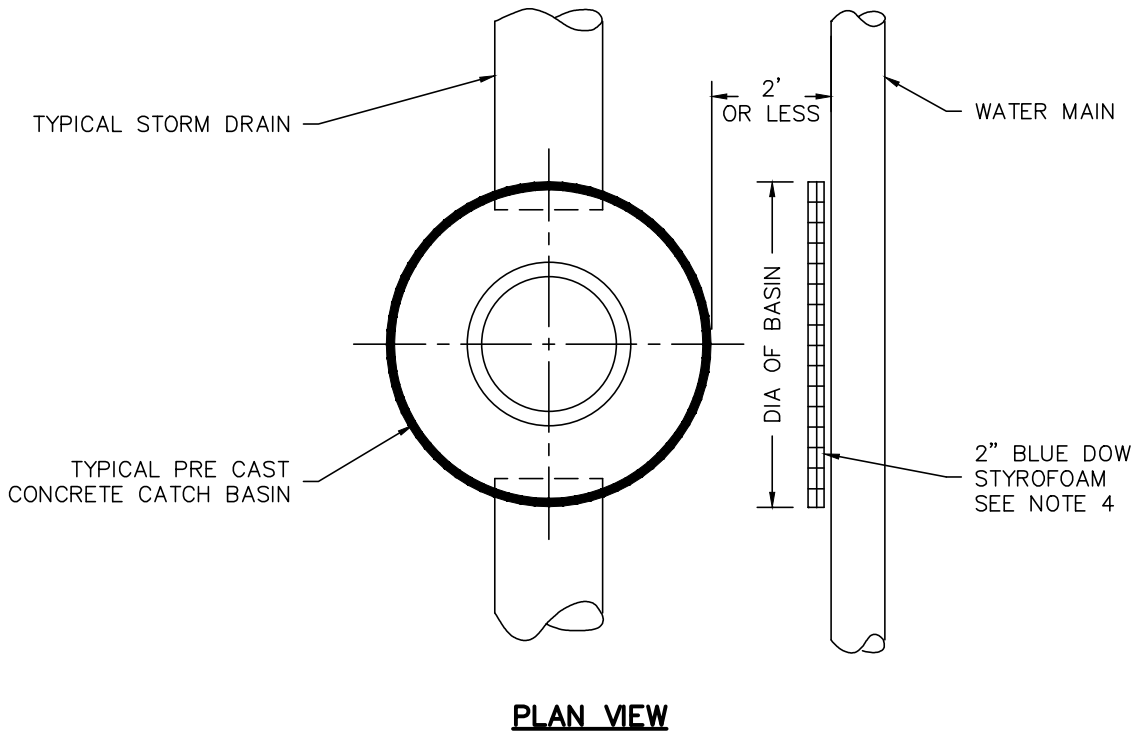

PLAN VIEW

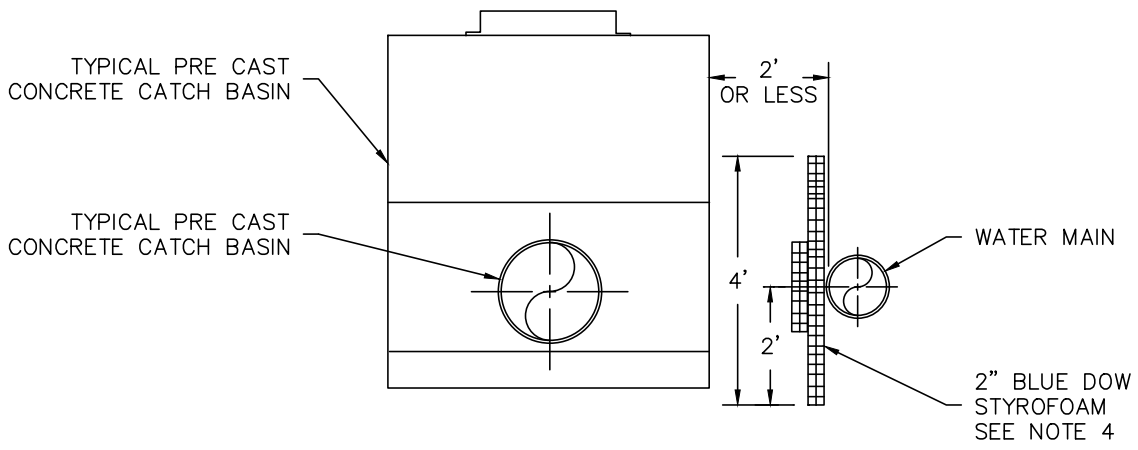

ELEVATION VIEW

NOTES:

1. ALL MATERIALS AND INSTALLATION PROCEDURES WILL CONFORM TO P.W.W. TECHNICAL SPECIFICATIONS.
2. ALL PIPE SHOULD HAVE A MINIMUM DEPTH OF 5' FROM TOP OF PIPE TO FINISH GRADE.
3. P.W.W., INC. RESERVES THE RIGHT TO MODIFY INSULATION REQUIREMENTS AS NECESSARY BASED ON FIELD CONDITIONS, ETC.
4. ALL BUTT JOINT SEAMS TO BE OVERLAPPED WITH 1' PIECE OF INSULATION CENTERED OVER SEAM.



DETAIL M16
TYPICAL CATCH BASIN
INSULATION DETAIL
 PENNICHUCK WATER WORKS, INC.
 REV: 03-18 SCALE: NTS

CONDITION I

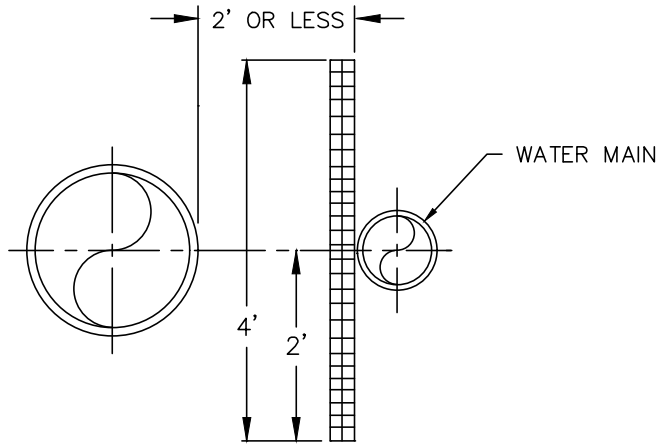

CONDITION II

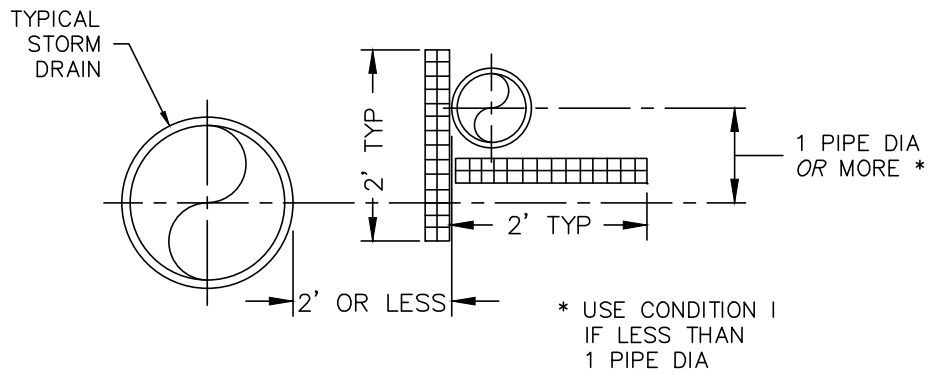

CONDITION III

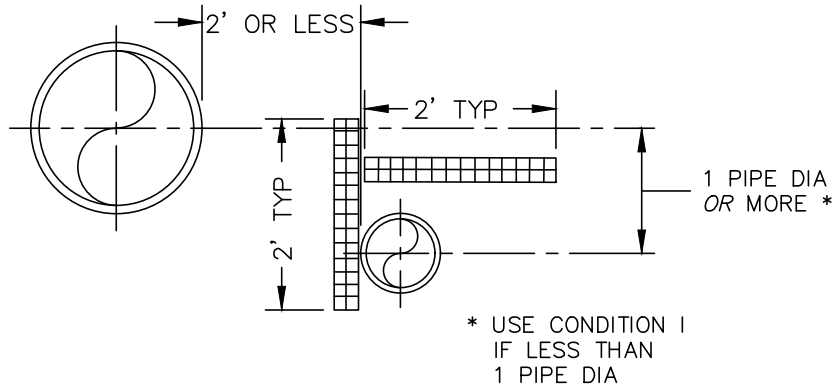

NOTES:

1. ALL MATERIALS AND INSTALLATION PROCEDURES WILL CONFORM TO P.W.W. TECHNICAL SPECIFICATIONS.
2. P.W.W., INC. RESERVES THE RIGHT TO MODIFY INSULATION REQUIREMENTS AS NECESSARY BASED ON FIELD CONDITIONS, ETC.
3. INSULATION TO BE RUN HORIZONTALLY AS LONG AS CONDITIONS I, II, OR III ABOVE EXIST. ALL BUTT JOINT SEAMS TO BE OVERLAPPED WITH 1' PIECE OF INSULATION CENTERED OVER SEAM.
4.  - 2" (MIN) BLUE DOW STYROFOAM



DETAIL M17
 STORM DRAIN / WATER MAIN
 PARALLEL RUNS - ELEVATION VIEW
 PENNICHUCK WATER WORKS, INC.
 REV: 03-18 SCALE: NTS

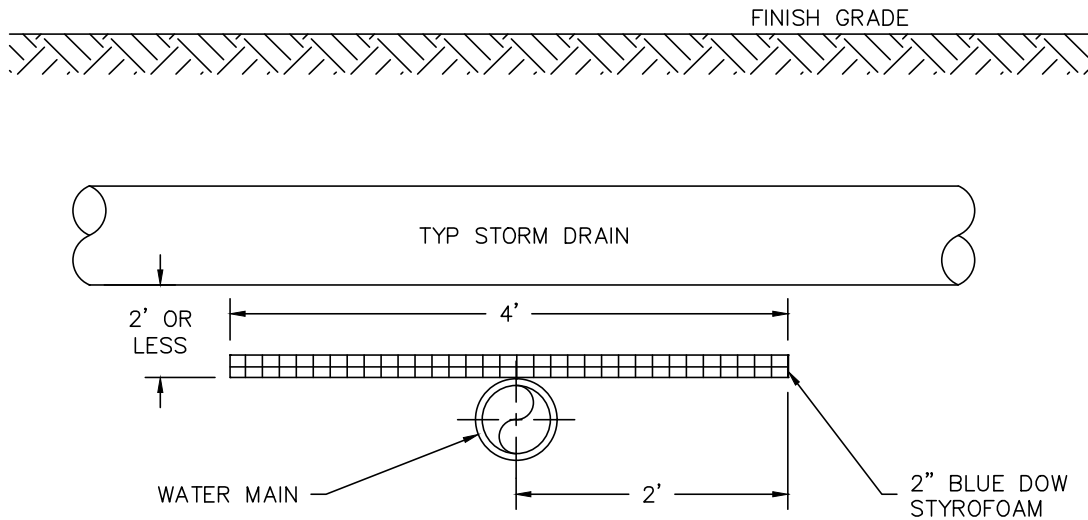

CONDITION I

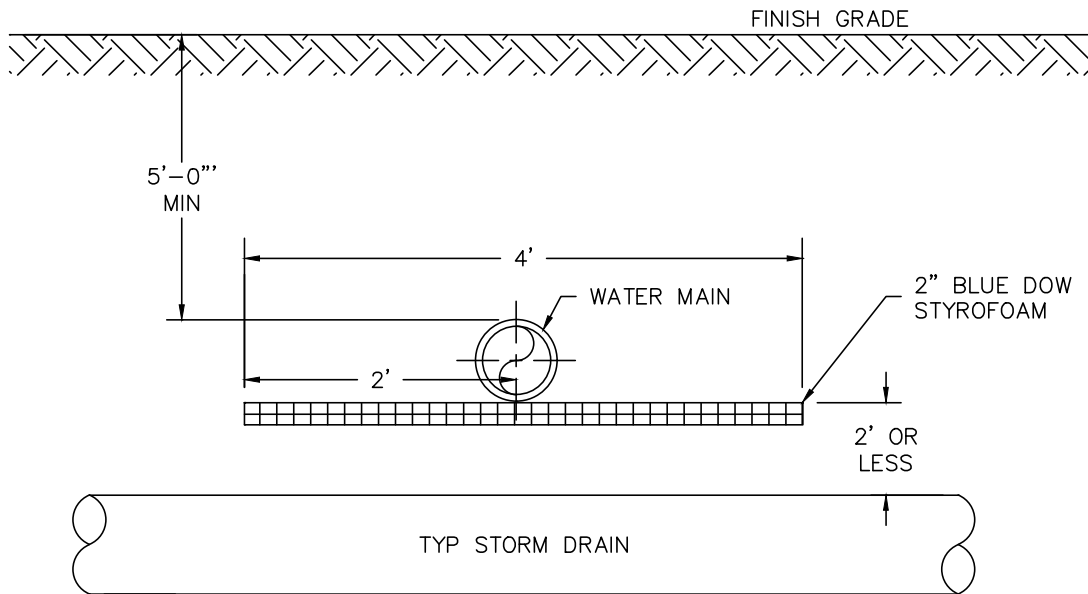

CONDITION II

NOTES:

1. PENNICHUCK WATER WORKS, INC. RESERVES THE RIGHT TO MODIFY INSULATION REQUIREMENTS AS NECESSARY BASED ON FIELD CONDITIONS, ETC.
2. THE LENGTH OR WIDTH OF INSULATION SHALL EXTEND 1 STORM DRAIN PIPE DIAMETER BEYOND THE EDGE OF STORM DRAIN PIPE IN EACH DIRECTION OR A MINIMUM OF 2' BEYOND THE CENTERLINE OF THE STORM DRAIN PIPE, WHICHEVER IS GREATER.
3. ALL BUTT JOINT SEAMS TO BE OVERLAPPED WITH A 1'-0" PIECE OF INSULATION CENTERED OVER SEAM.



DETAIL M18
 STORM DRAIN / WATER MAIN
 INTERSECTING RUNS - ELEV. VIEW
 PENNICHUCK WATER WORKS, INC.
 REV: 03-18 SCALE: NTS

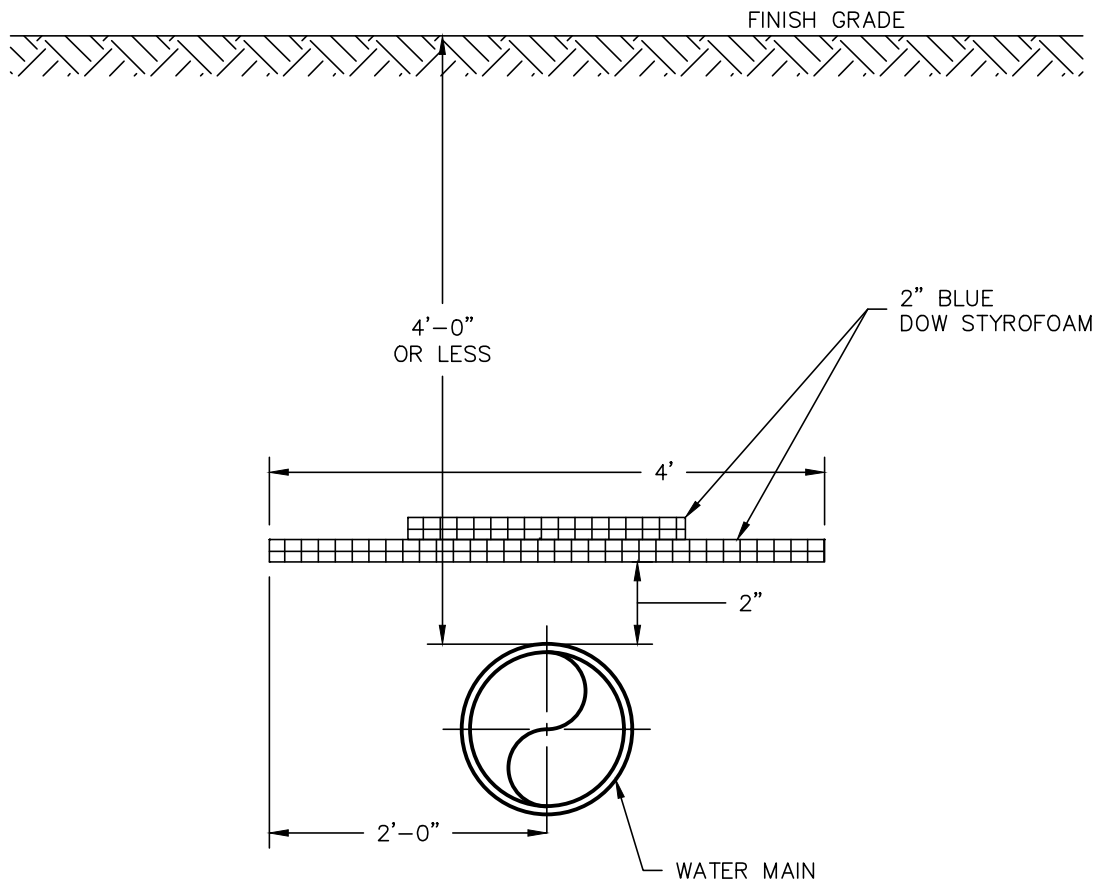

NOTES:

1. ALL MATERIALS AND INSTALLATION PROCEDURES WILL CONFORM TO P.W.W. TECHNICAL SPECIFICATIONS.
2. P.W.W., INC. RESERVES THE RIGHT TO MODIFY INSULATION REQUIREMENTS AS NECESSARY BASED ON FIELD CONDITIONS, ETC.
3. ALL BUTT JOINT SEAMS TO BE OVERLAPPED WITH 2" PIECE OF INSULATION CENTERED OVER SEAM.



DETAIL M19
TYPICAL INSULATION DETAIL FOR
LESS THAN 4'-0" OF COVER
 PENNICHUCK WATER WORKS, INC.
 REV: 03-18 SCALE: NTS

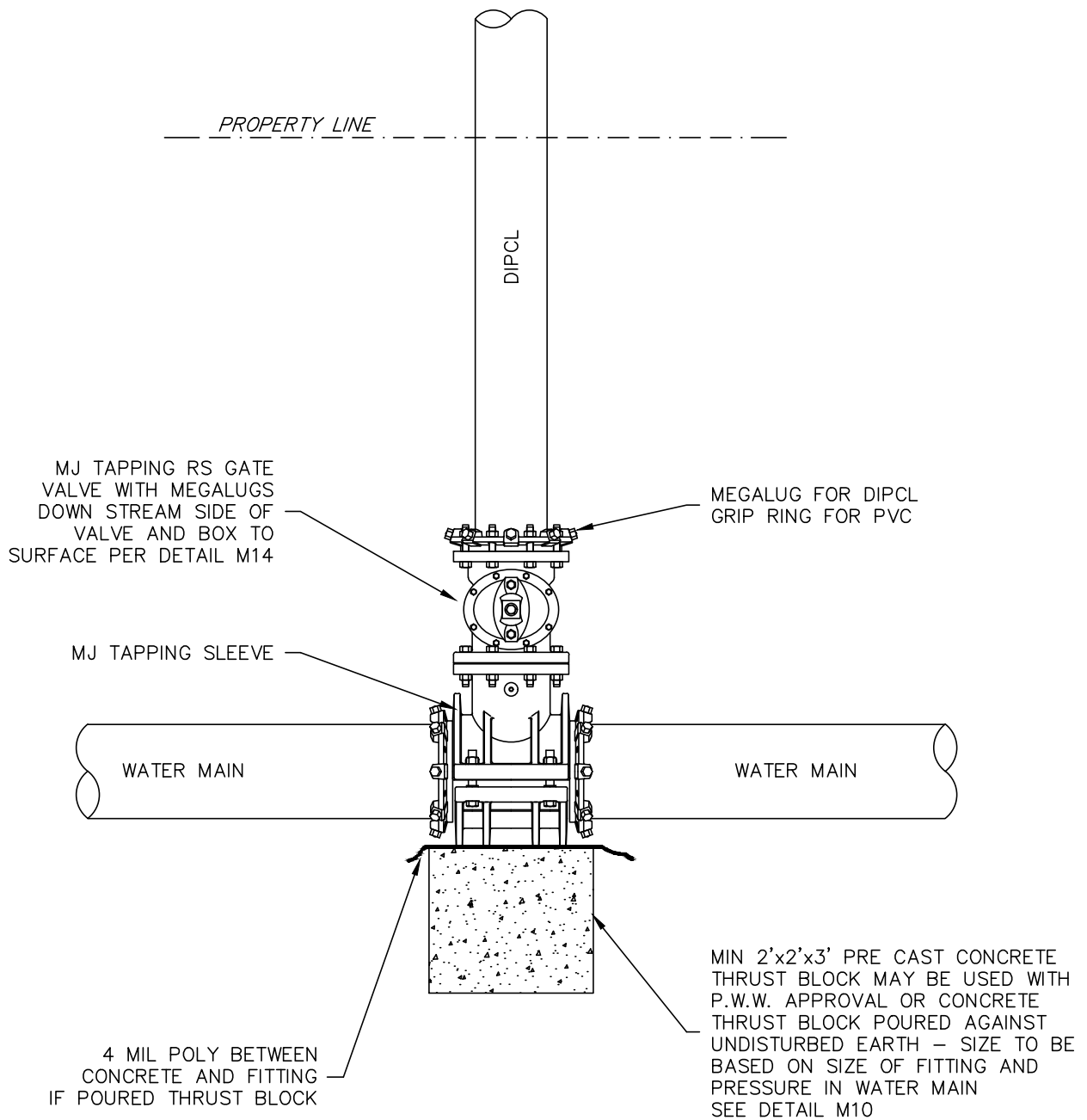

NOTES:

1. ALL MATERIALS AND INSTALLATION PROCEDURES WILL CONFORM TO P.W.W. TECHNICAL SPECIFICATIONS.
2. SEE DETAIL F01 FOR CROSS-SECTIONAL VIEW.



DETAIL M20
TYPICAL LARGE SERVICE AND/OR
TAPPING SLEEVE DETAIL
 PENNICHUCK WATER WORKS, INC.
 REV: 11-1-2021 SCALE: NTS

NOTE:
INITIAL INSTALLATION OF
CONSTRUCTION METER BY
PWW METER DEPT.

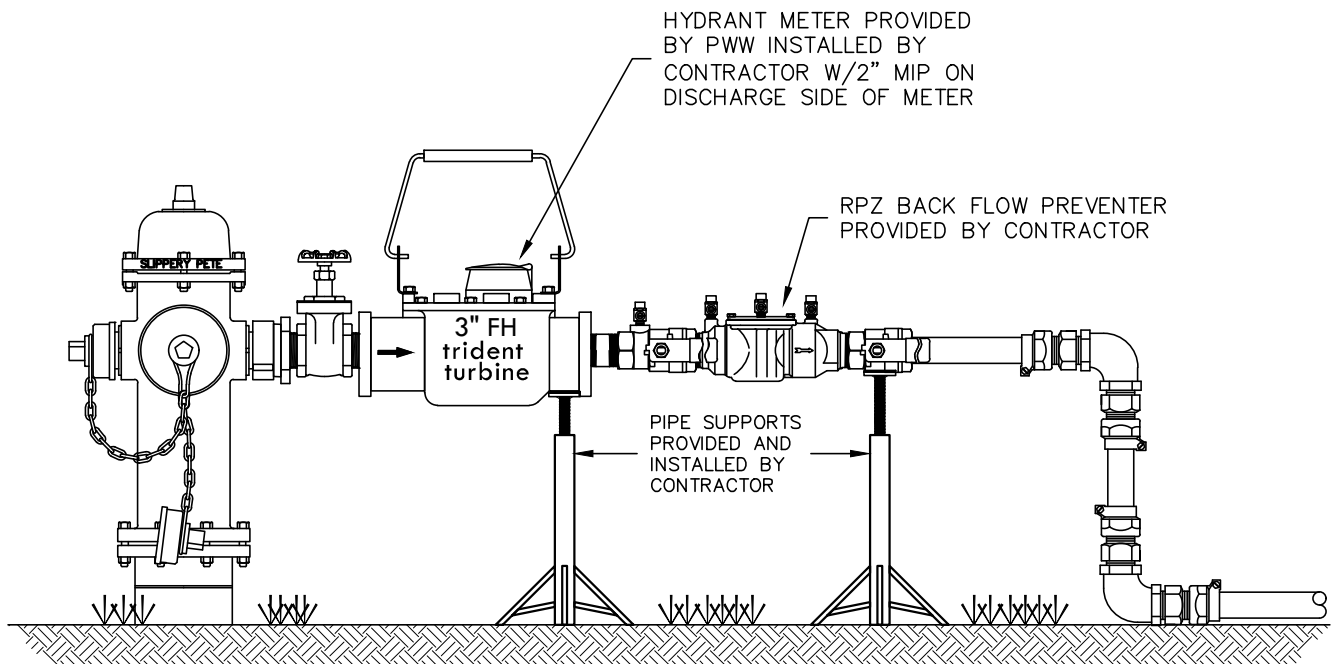

APPLICATION NOTES:

1. USE DESIGNATED HYDRANT ONLY
2. CONTRACTOR IS RESPONSIBLE TO PROTECT THE METER FROM THEFT, DAMAGE AND FREEZING
3. INITIATE AND TERMINATE WATER FLOW SLOWLY.
4. CONTACT PENNICHUCK WATER METER DEPARTMENT TO RELOCATE METER ASSEMBLY TO A DIFFERENT FIRE HYDRANT (603-913-2391)
5. HYDRANT METERS ARE AVAILABLE FROM APRIL 15TH TO NOVEMBER 15TH.



DETAIL T01
TYPICAL CONSTRUCTION METER
INSTALLATION DETAIL
PENNICHUCK WATER WORKS, INC.
REV: 03-18 SCALE: NTS

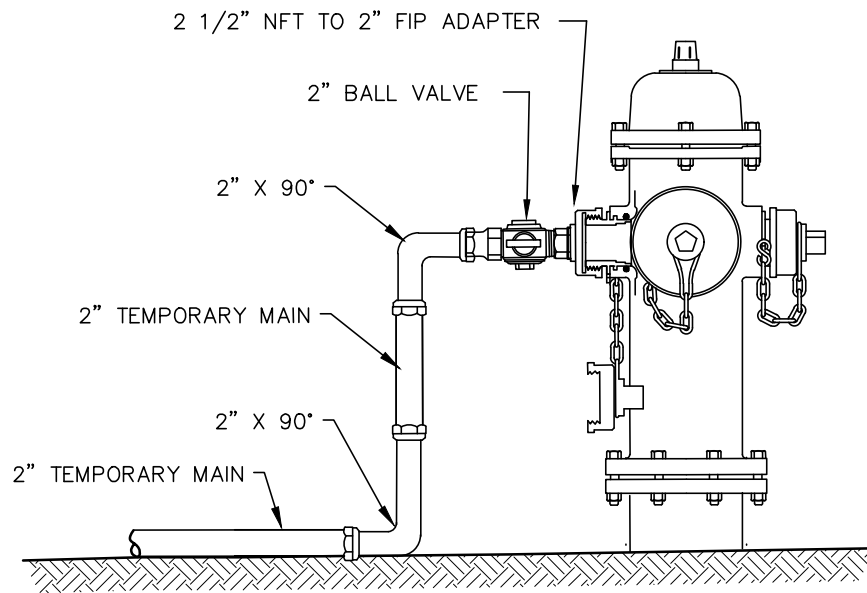

DETAIL "AA"

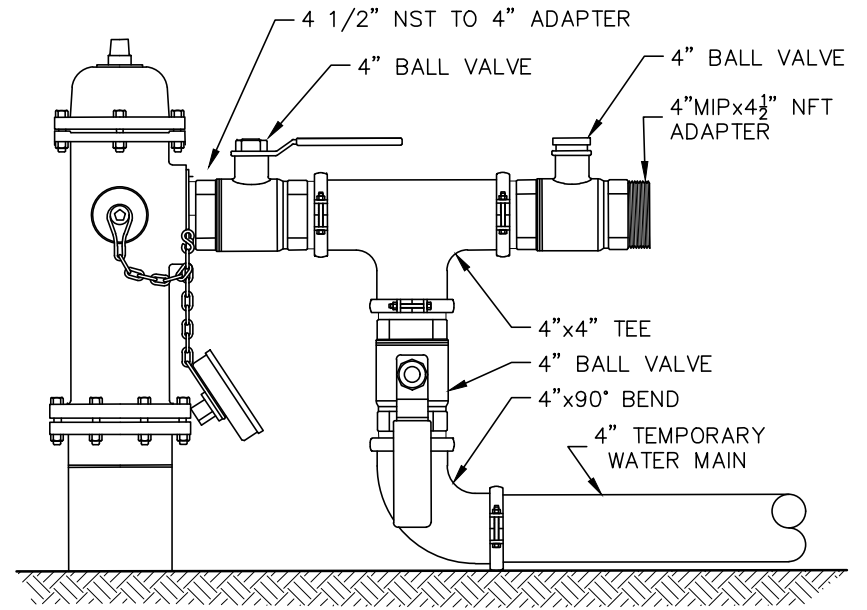

DETAIL "BB"



DETAIL T02
TEMPORARY MAIN FED
FROM A HYDRANT
 PENNICHUCK WATER WORKS, INC.
 REV: 03-18 SCALE: NTS

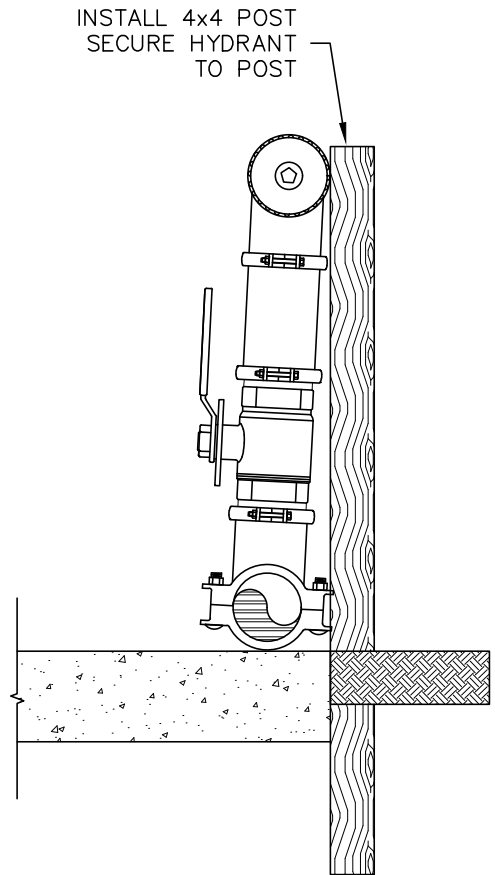
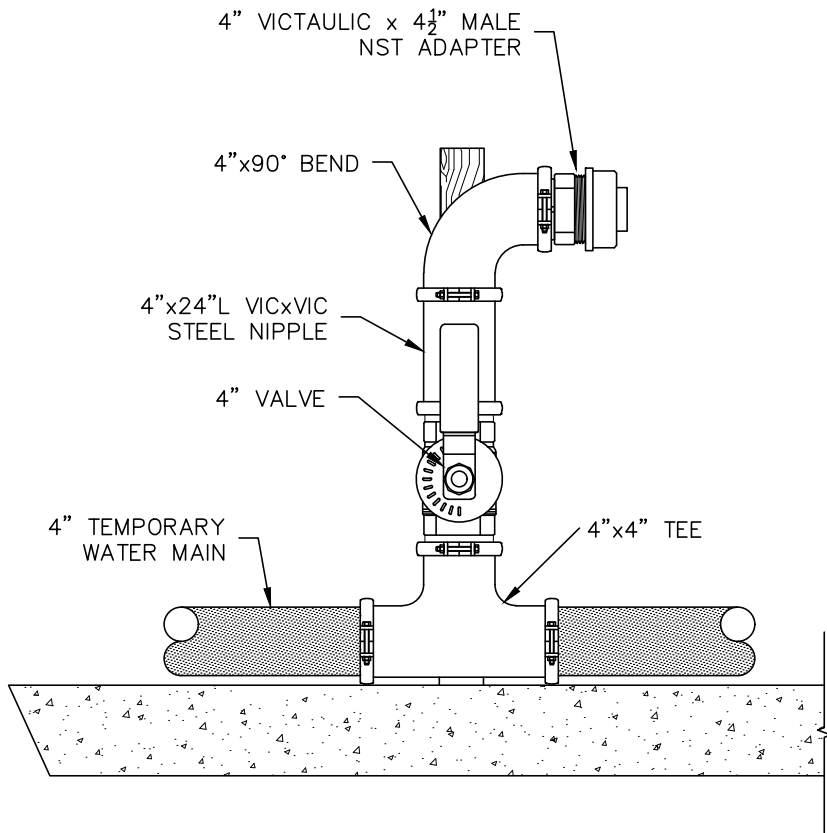

DETAIL T03
 TYPICAL FIRE DEPARTMENT
 CONNECTION ON TEMP. MAIN
 PENNICHUCK WATER WORKS, INC.
 REV: 03-18 SCALE: NTS

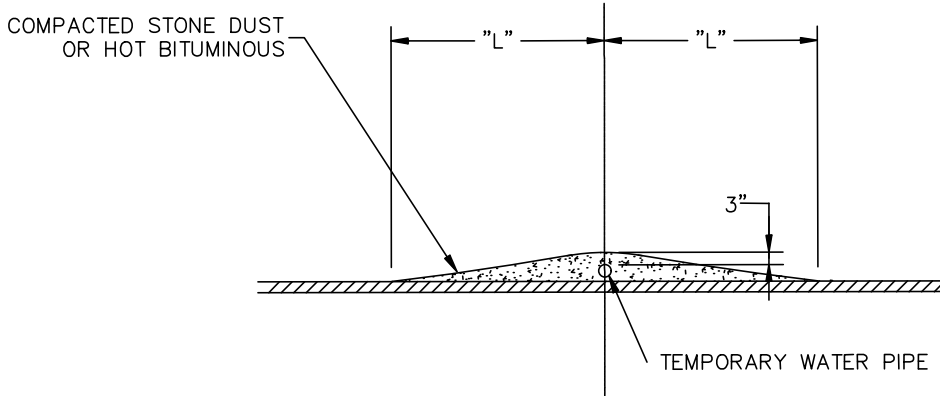
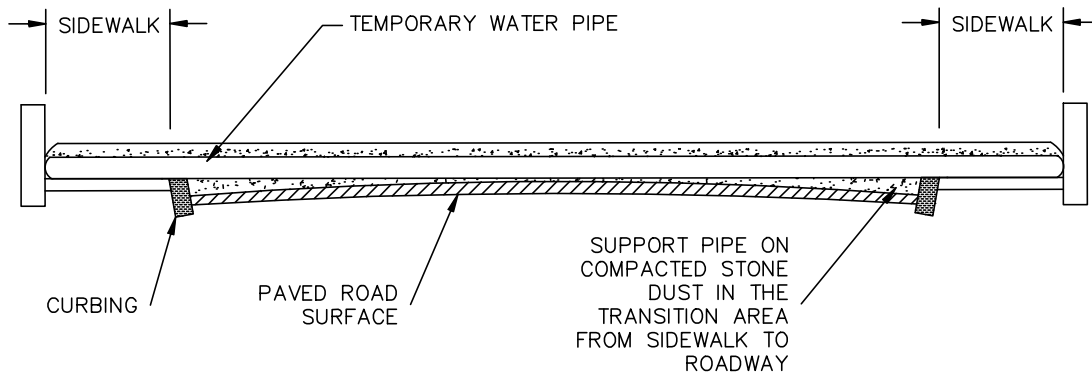

TEMPORARY WATER PIPE SIZE	"L" DIMENSION
1"	3 FT
2"	4 FT
4"	6 FT

NOTE:
FOR LOW TRAFFIC ROADS ONLY



DETAIL T04
TEMPORARY PEDESTRIAN/ROADWAY
CROSSING DETAIL
 PENNICHUCK WATER WORKS, INC.
 REV: 03-18 SCALE: NTS